



UNIVERSIDAD DISTRITAL FRANCISCO JOSÉ DE CALDAS

ANEXO 10.8 DOCUMENTO DE COTIZACIÓN MOBILIARIO PROYECTO AMPLIACIÓN SEDE TECNOLÓGICA.

LOTE 2

Mobiliario especializado

NOTA:

- 1-Se requiere hacer una visita técnica a obra, previa al inicio de la fabricación del mobiliario para corroborar medidas en sitio, la ubicación del mobiliario y las distintas acometidas en el caso que lo requieran.
- 2- Se aclara que la información suministrada a continuación corresponde a planos guía y deben ser tomados únicamente como apoyo y sugerencia para la realización y desarrollo de los muebles solicitados por la Universidad

SOLO ESPECIFICACIÓN TÉCNICA

ME 2.2

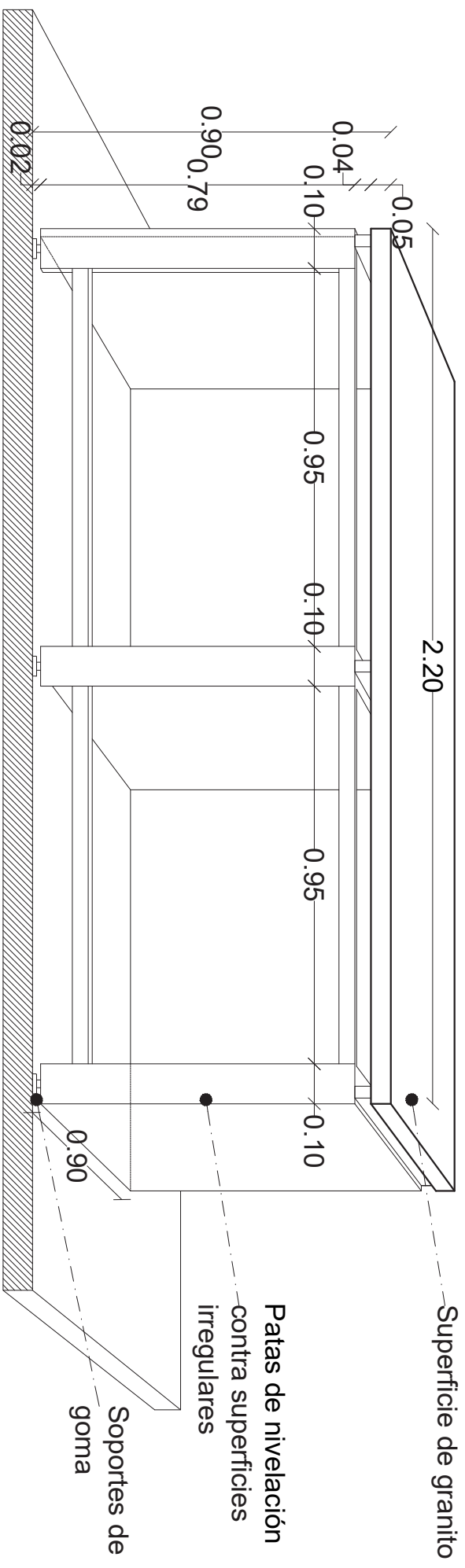

ME 2.3

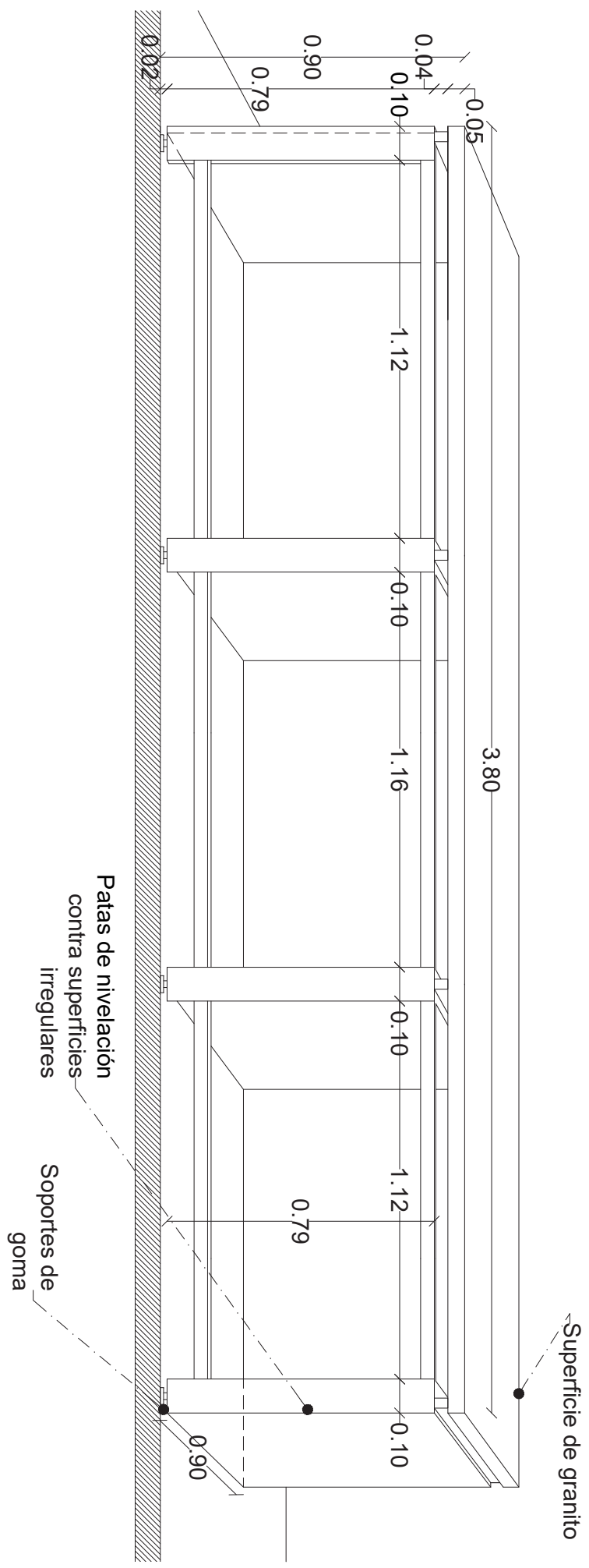

ME 2.4

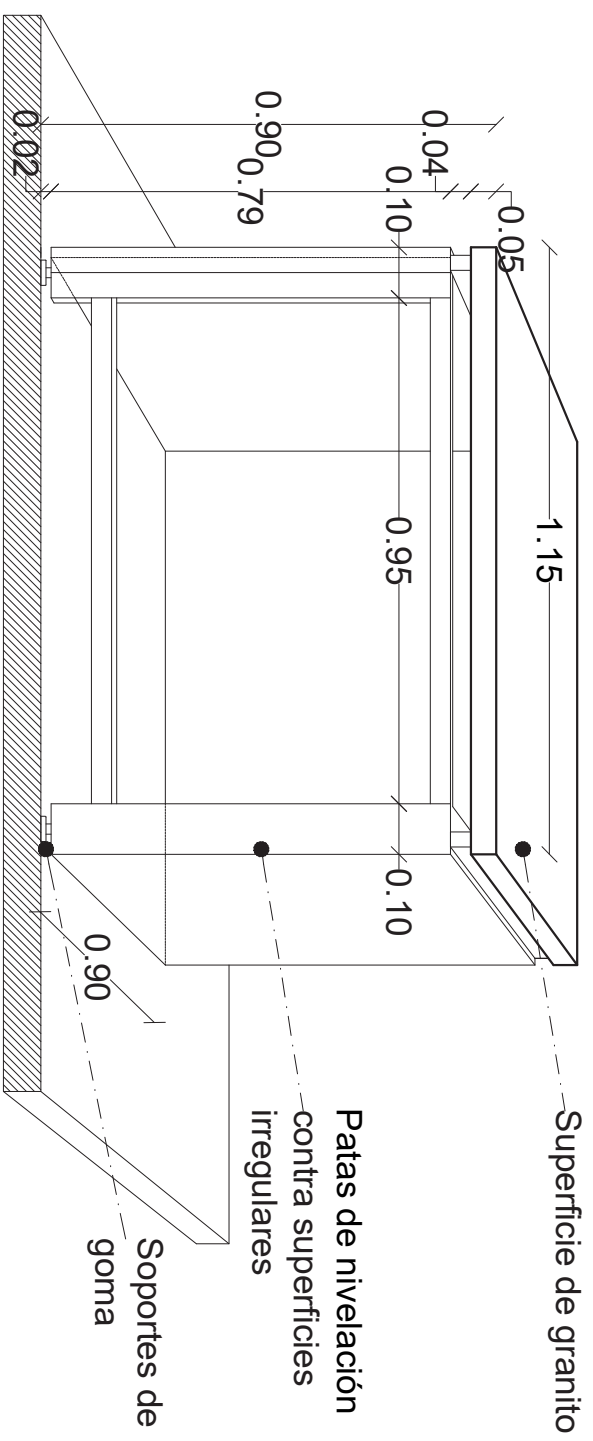

ME 2.5

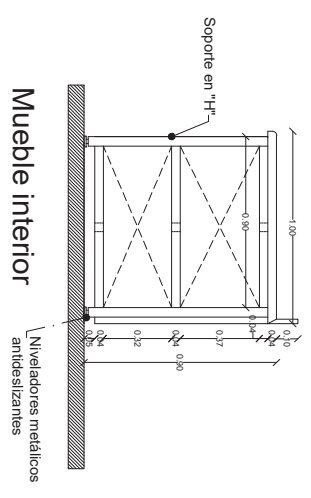
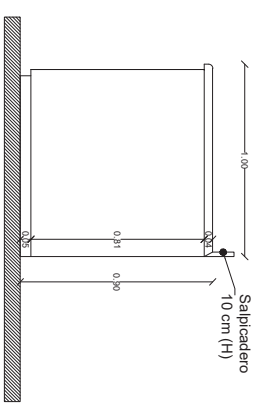
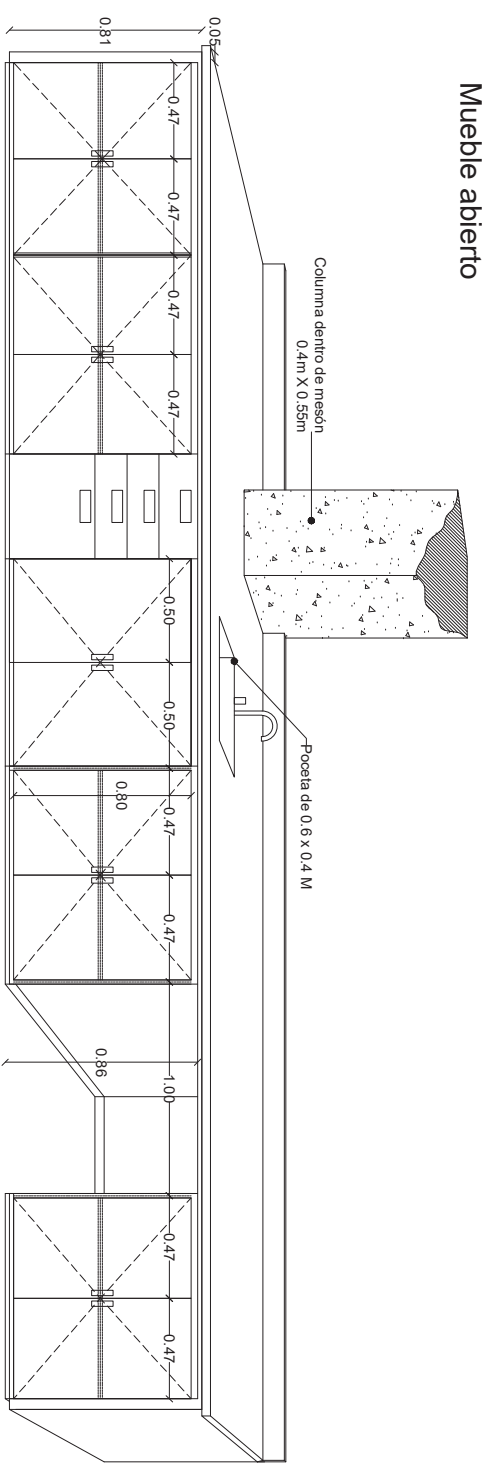
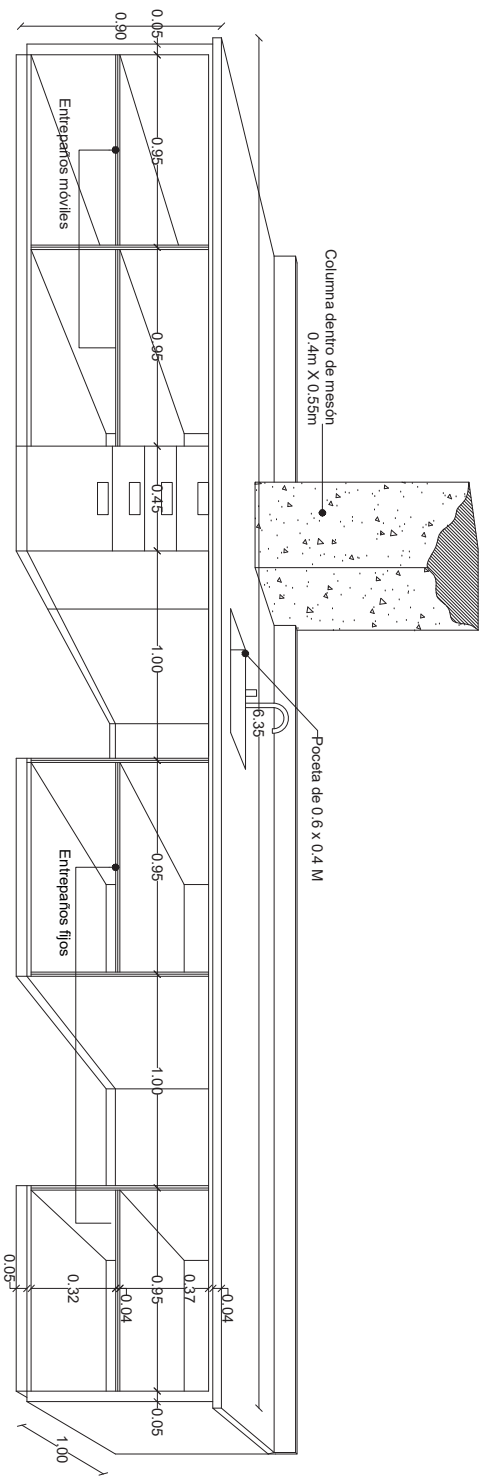

ME 2.6

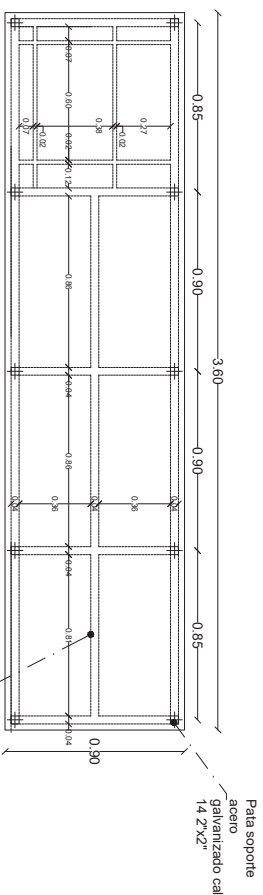

Planta soporte estructural superficie

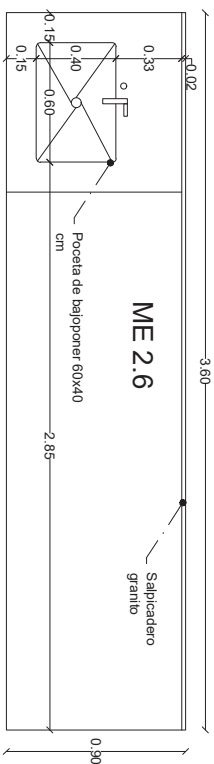

Planta

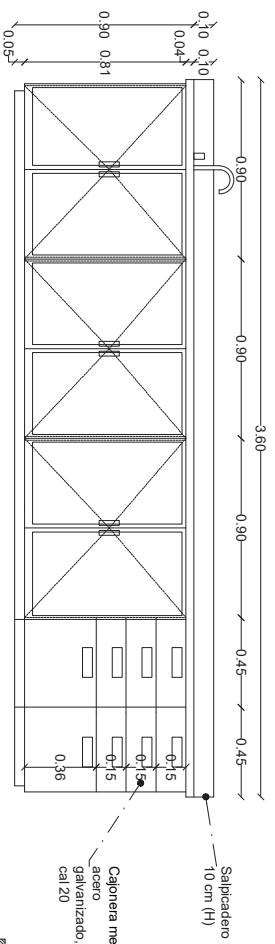

Mueble Cerrado

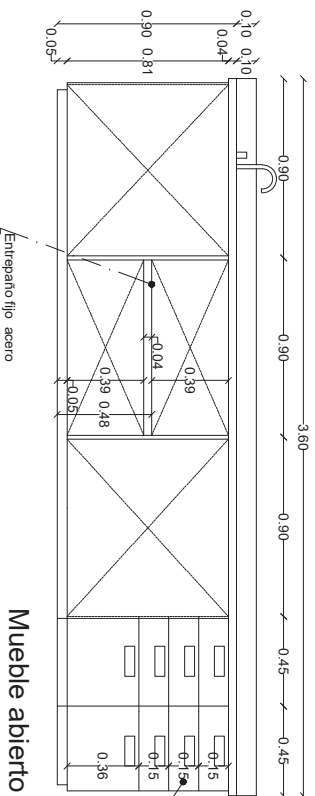
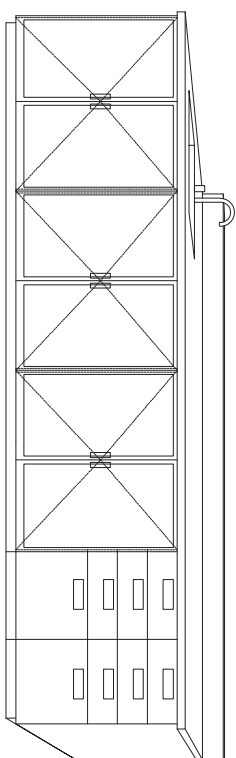

Mueble abierto

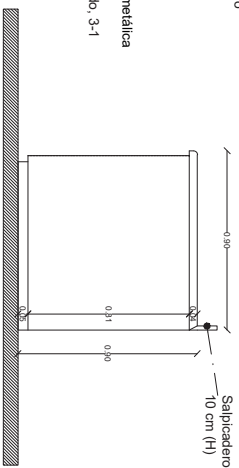

Mueble exterior

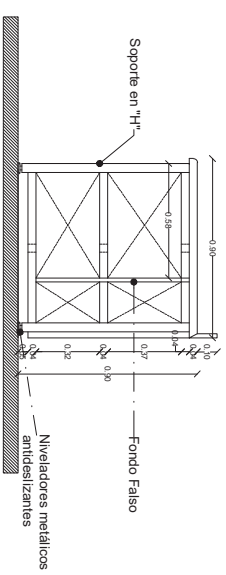

Mueble interior

ME 2.7

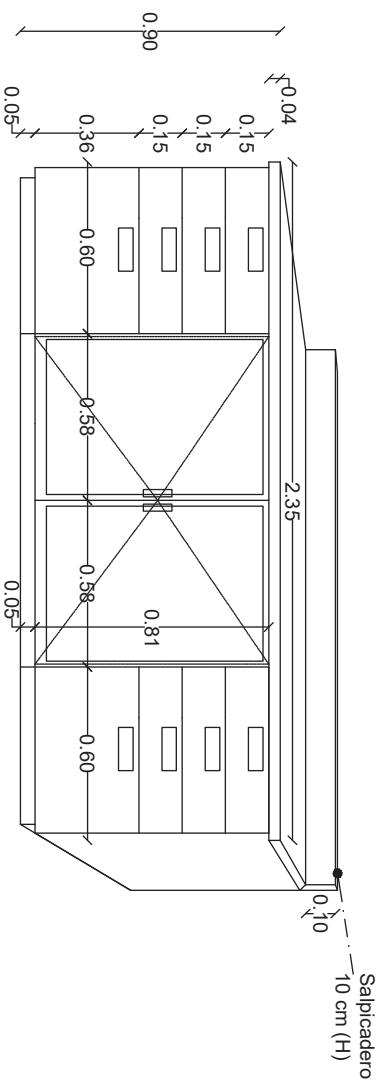

Mueble Exterior

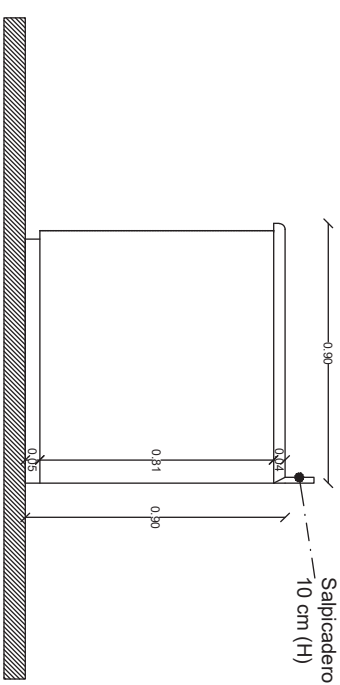

Mueble Exterior

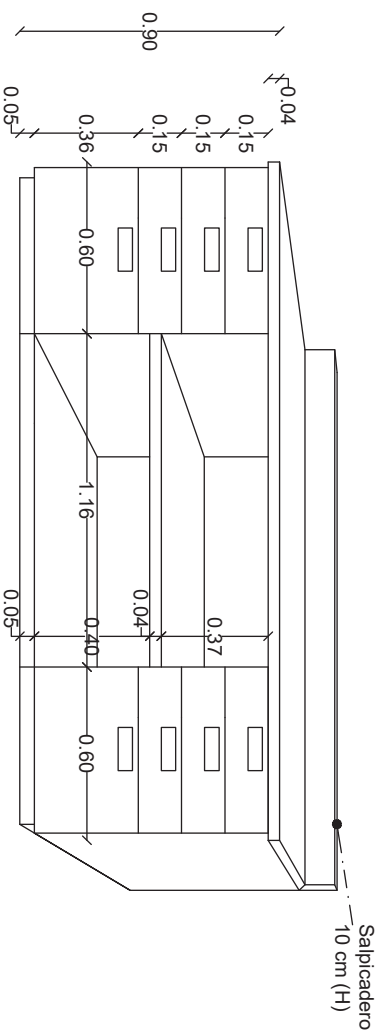

Mueble Interior

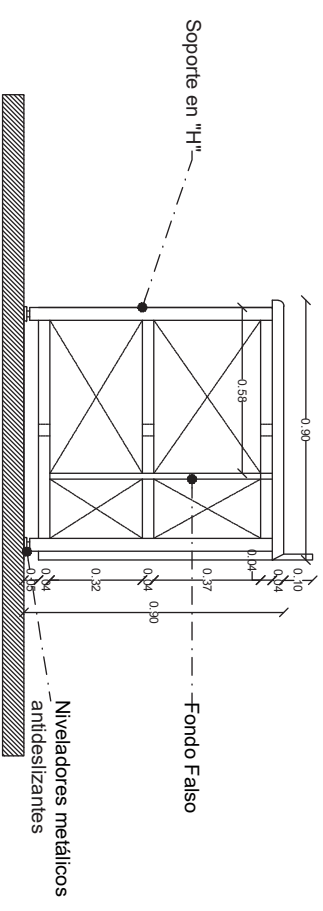

Mueble interior

ME 2.8

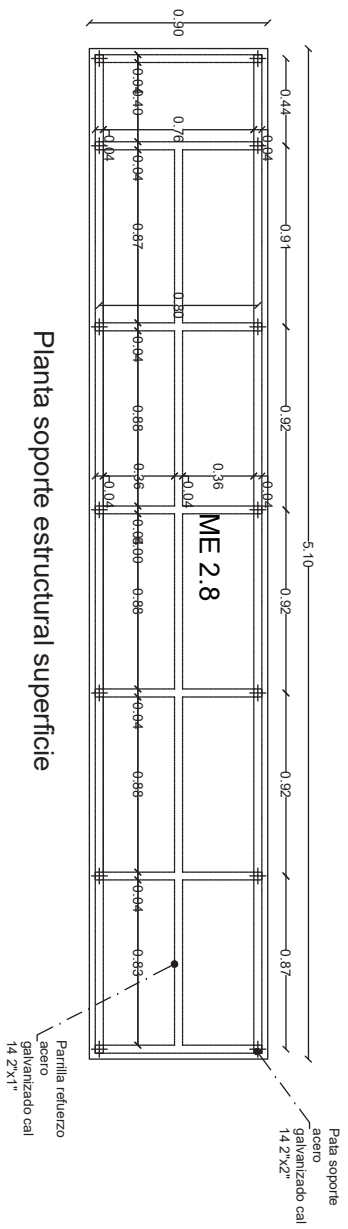

Planta soporte estructural superficie

ME 2.8

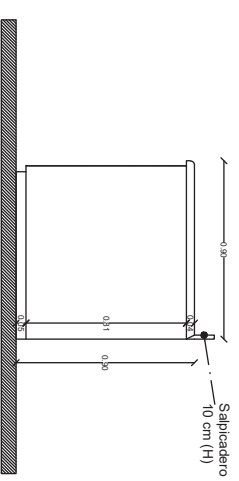

Mueble Exterior

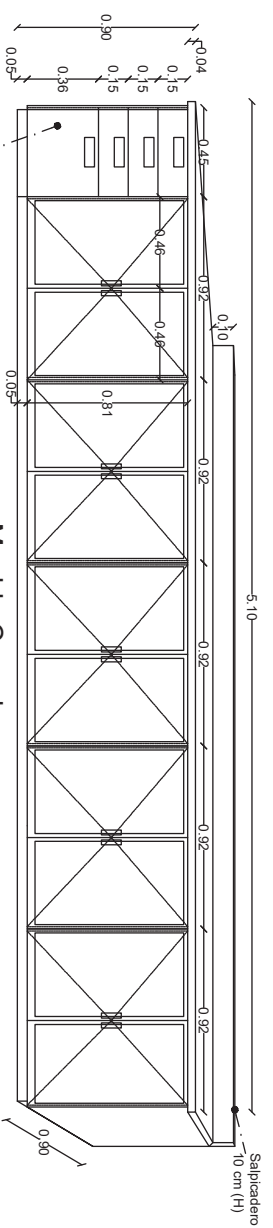

Mueble Cerrado

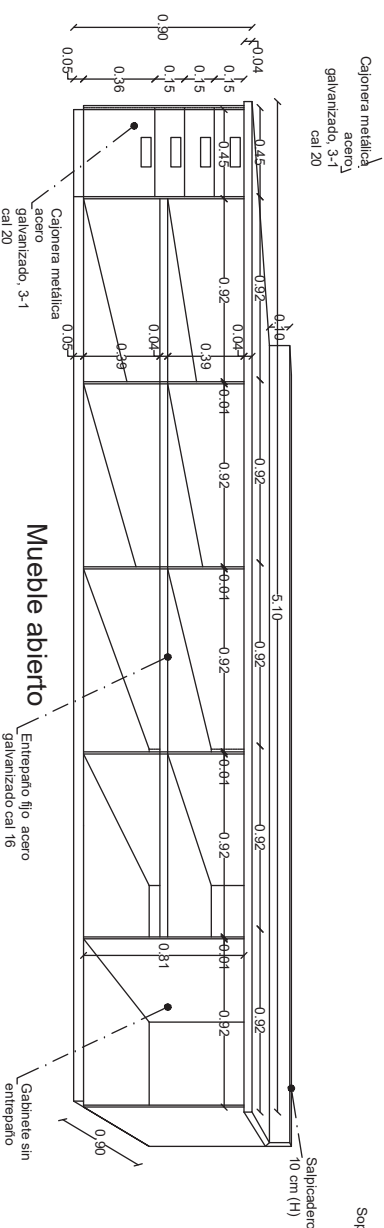

Mueble abierto

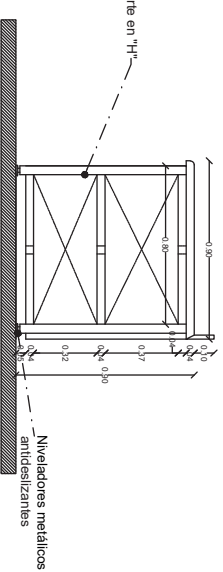

Mueble interior

ME 2.9

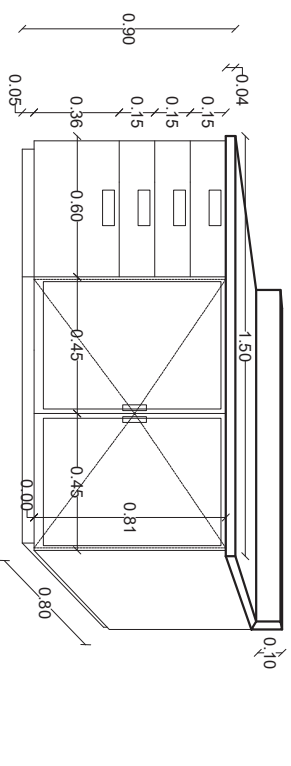

Mueble Exterior

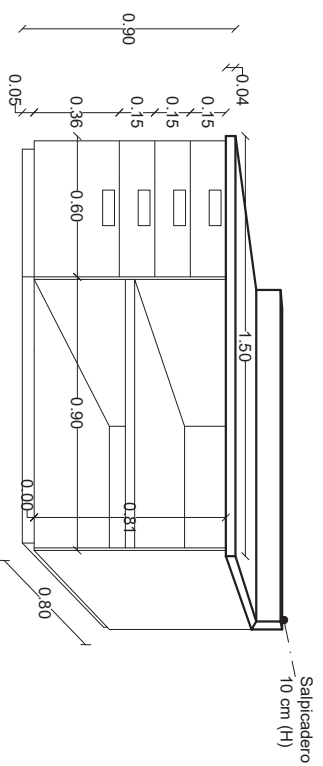
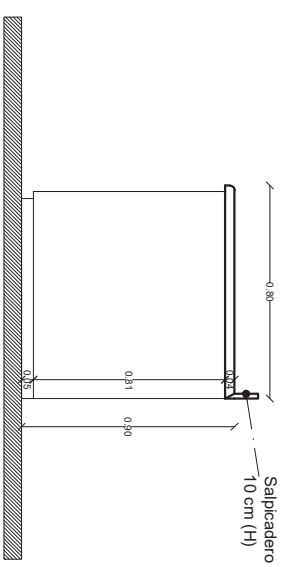

Mueble Interior

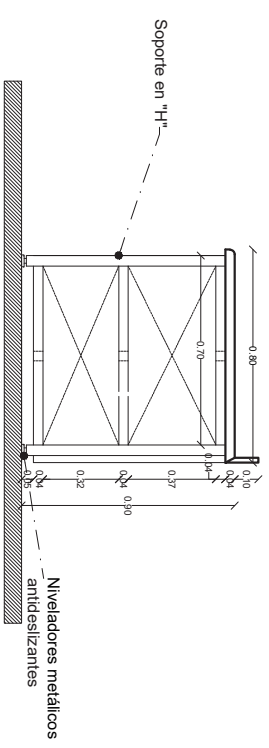

Mueble interior

ME 2.10

ME 2.10

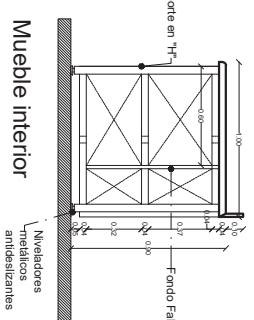
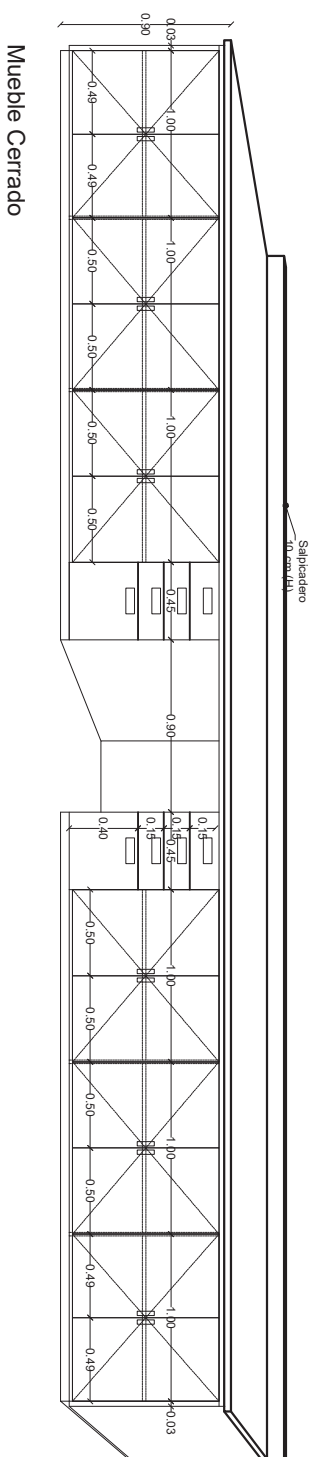
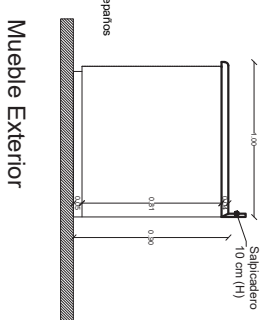
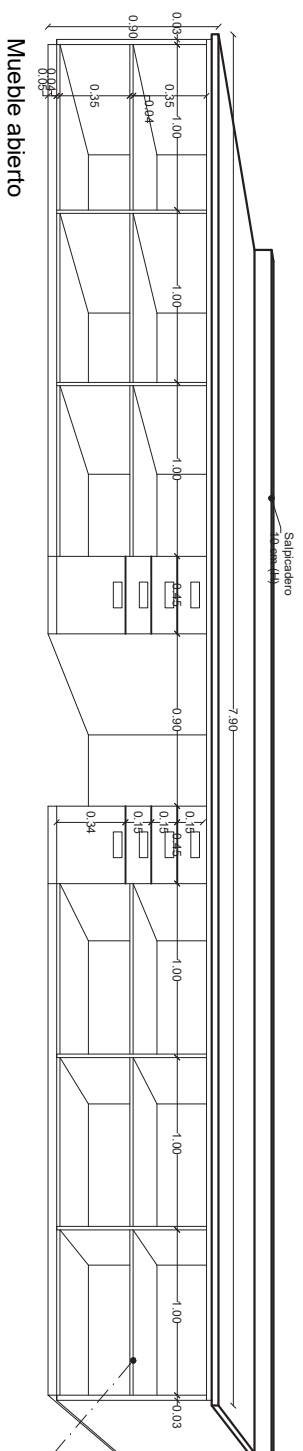

ME 2.11

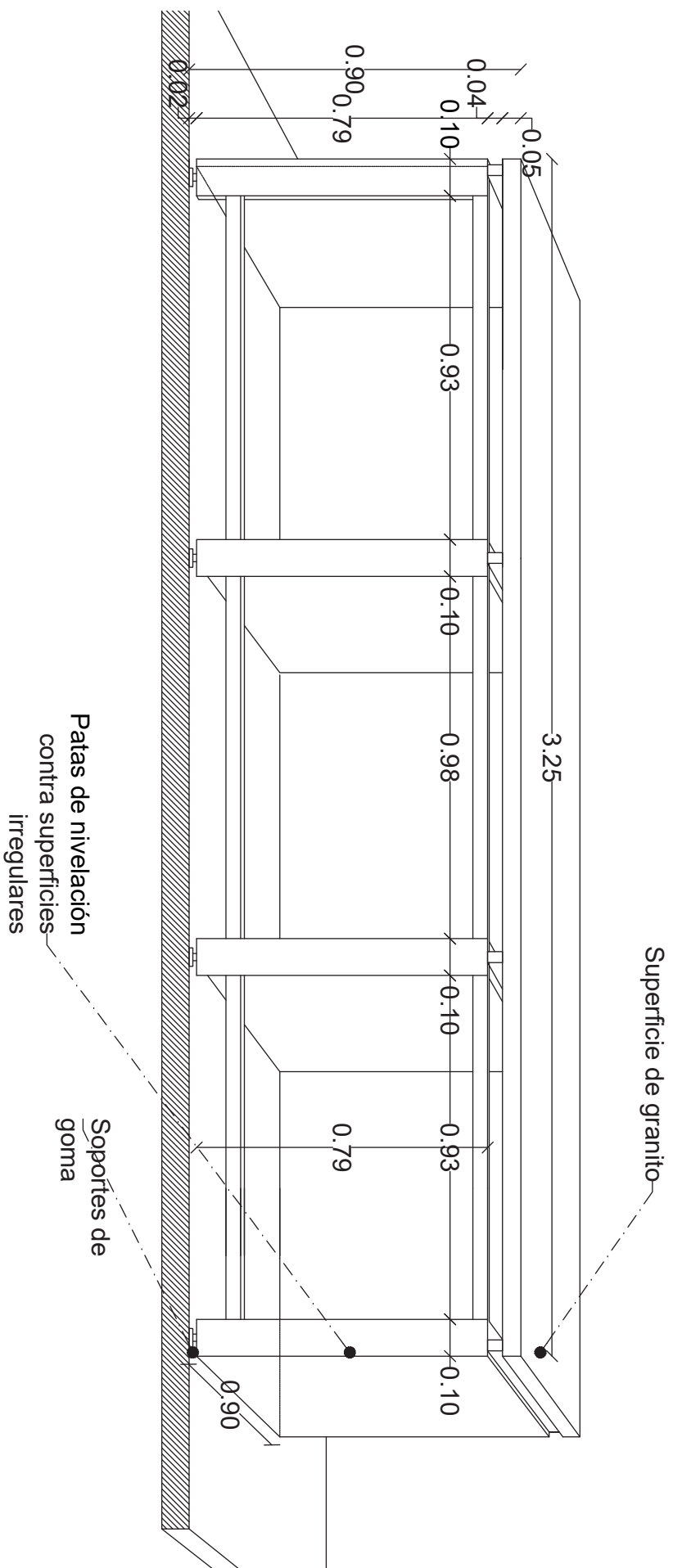

ME 2.12

ME 2.12

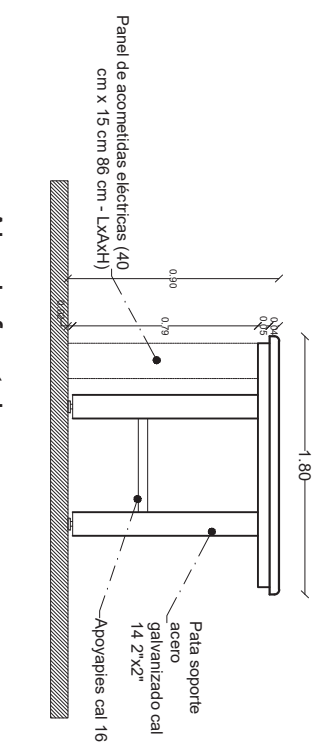
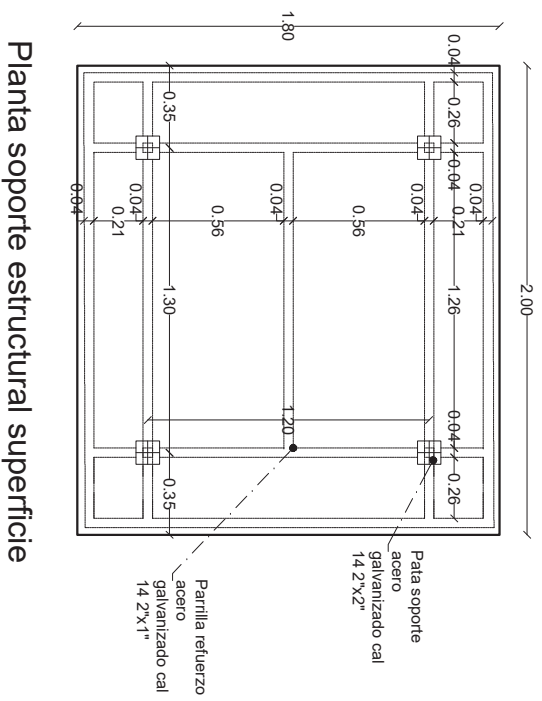

Planta soporte estructural superficie

Alzado frontal

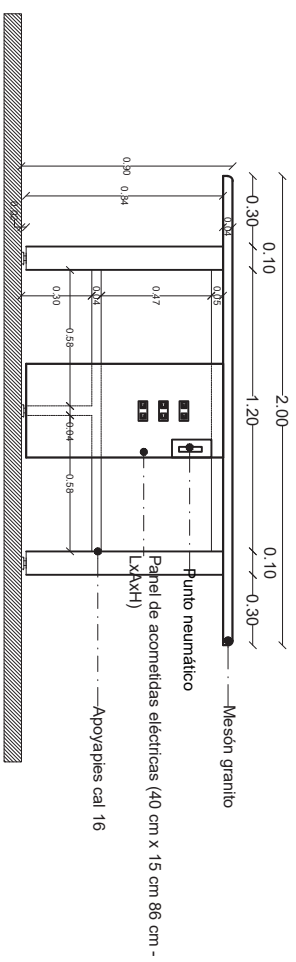

ME.2.13

ME.2.13

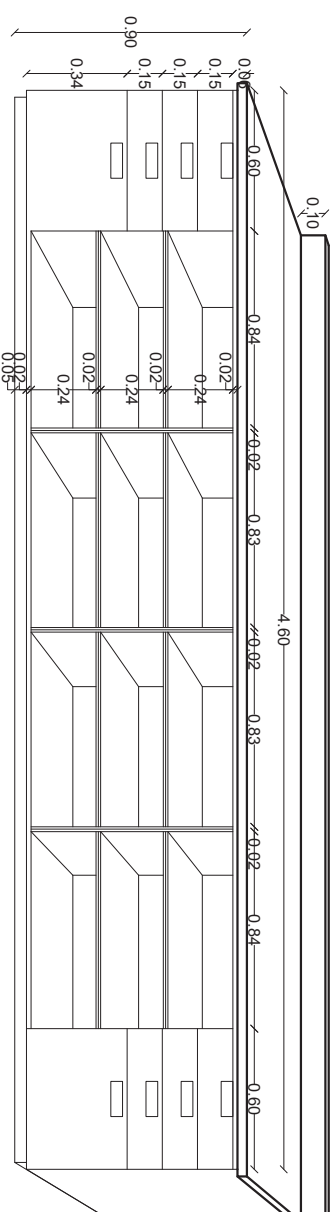

Mueble abierto

Salpicadero
10 cm (H)

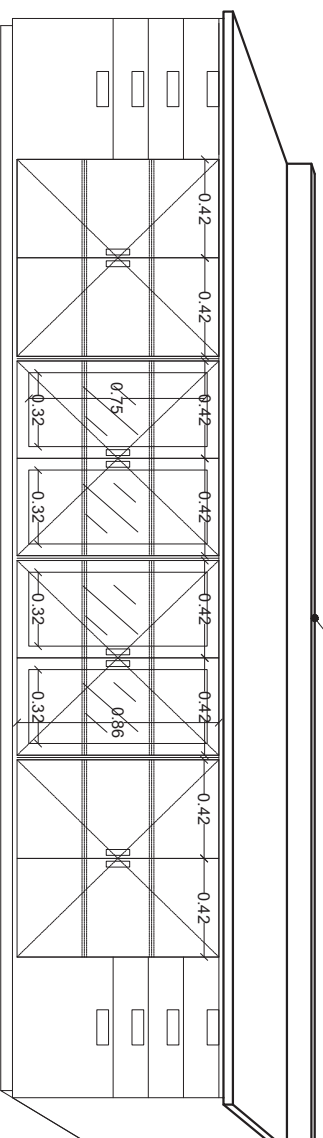

Mueble Cerrado

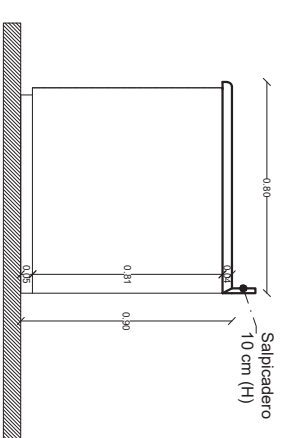

Mueble Exterior

Salpicadero
10 cm (H)

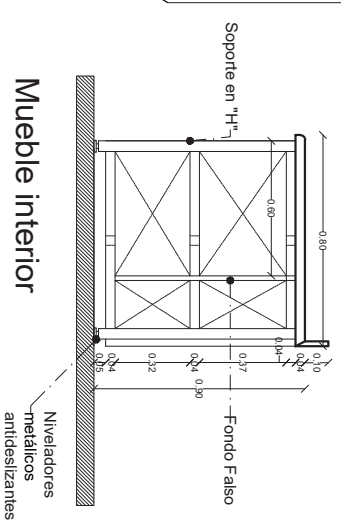

Mueble interior

Soporte en "H"

Fondo Falso

Niveladores metálicos antideslizantes

ME 2.14

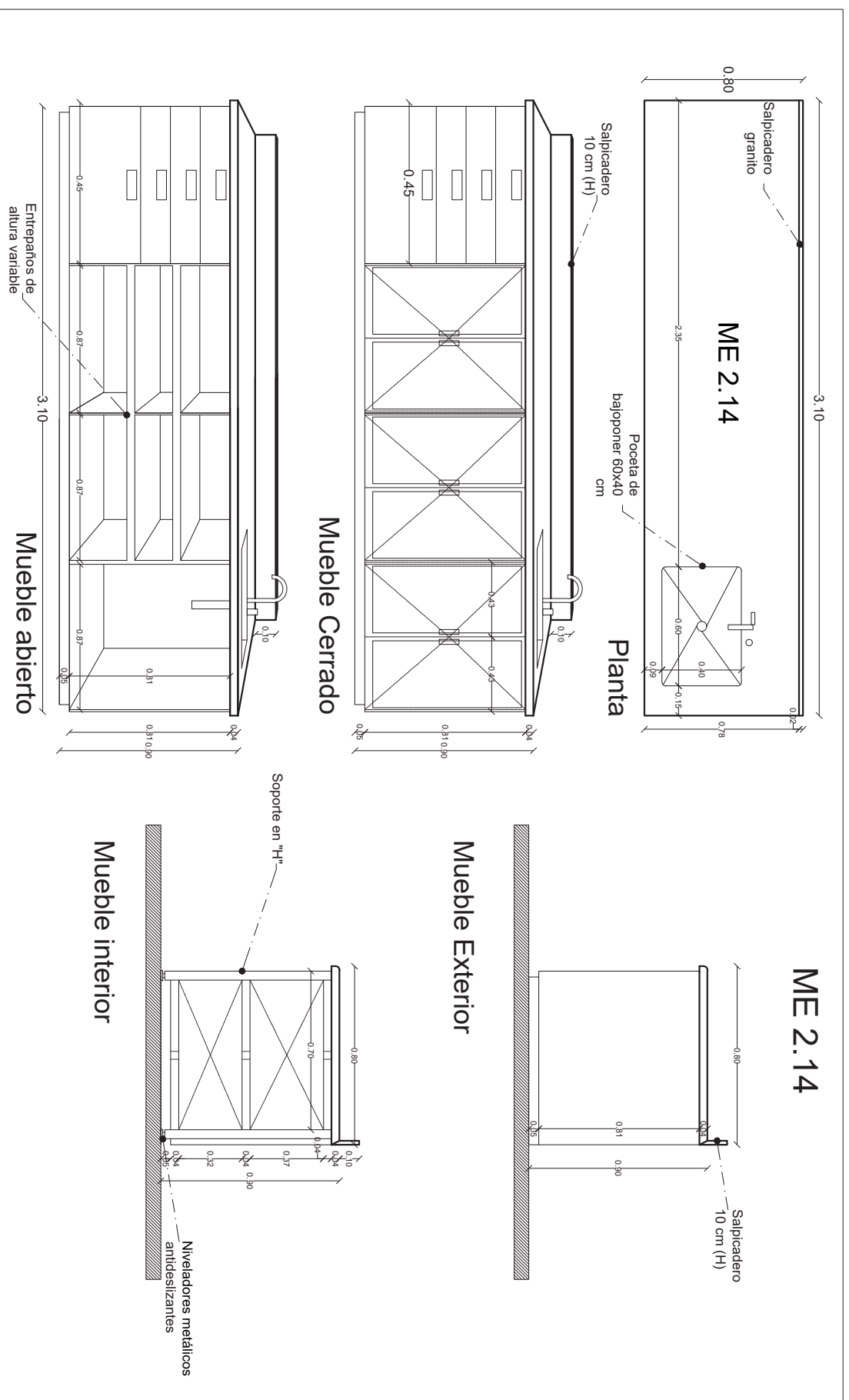

ME.2.15

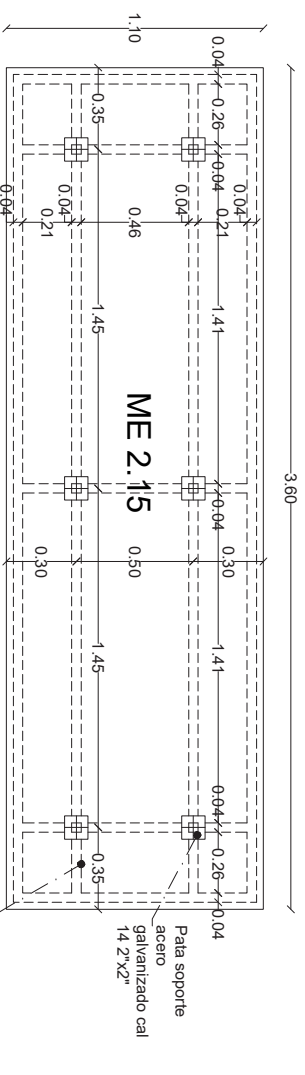

Planta - Soporte estructural superficie

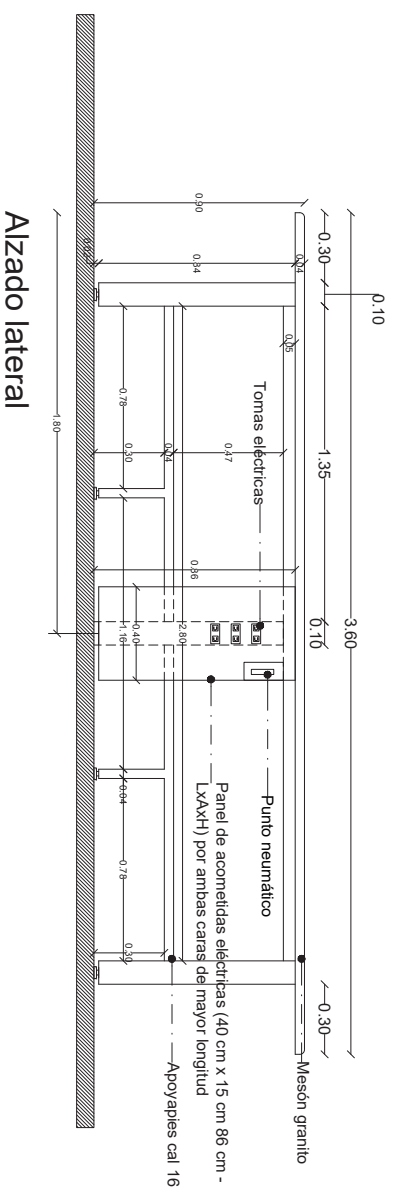

Alzado lateral

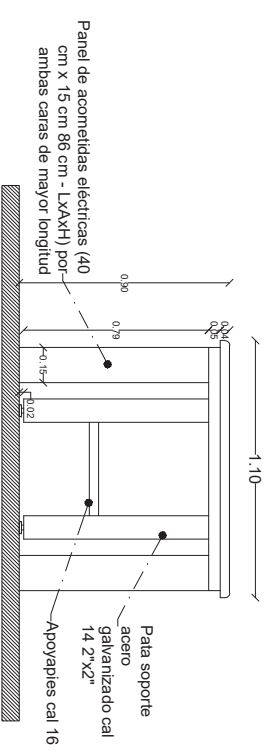

Alzado frontal

ME 2.16

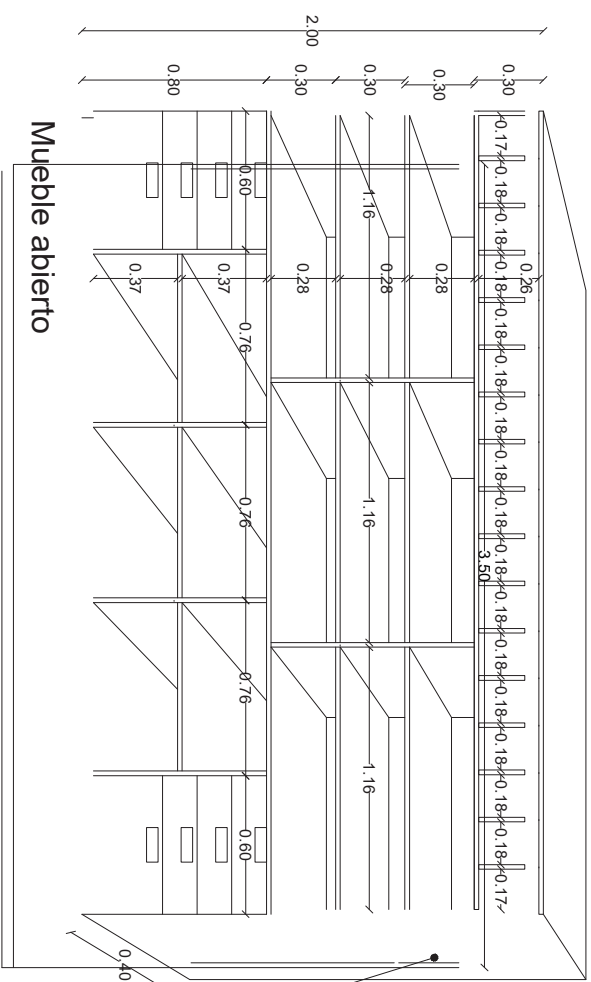

Mueble abierto

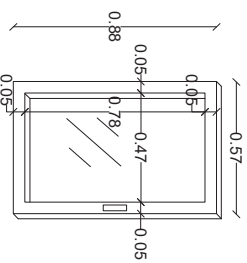

Detalle puerta pivotante

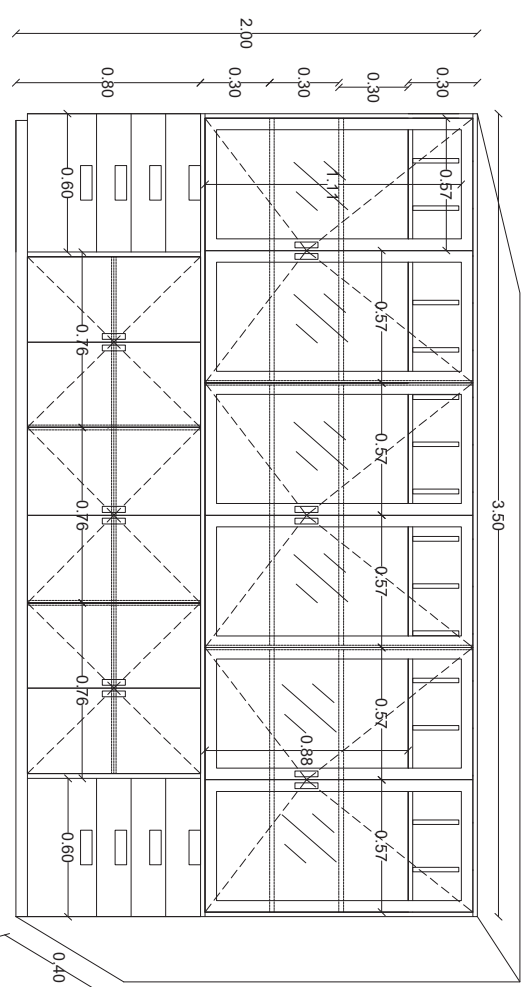

Mueble Cerrado

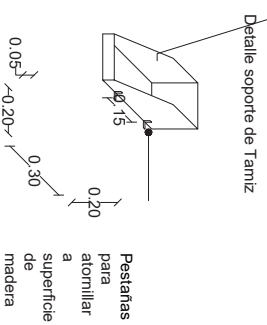

Detalle soporte de Tamiz

Pestañas para atornillar a superficie de madera

ME 2.17

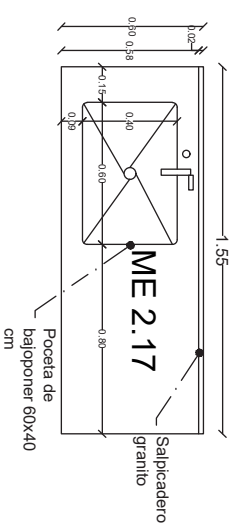

Planta

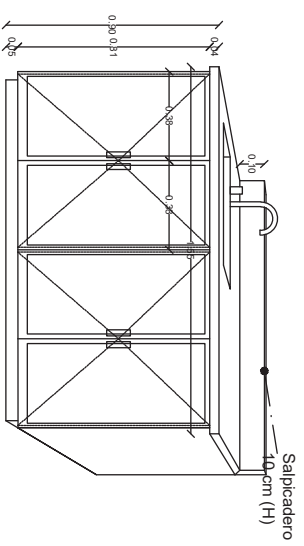

Mueble Cerrado

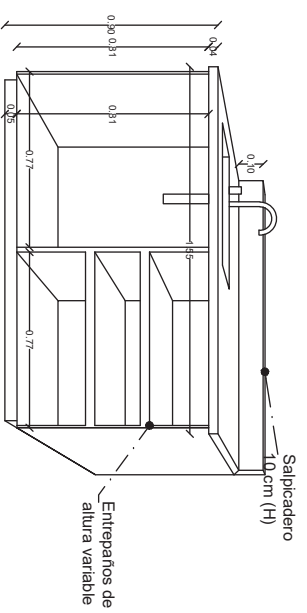

Mueble abierto

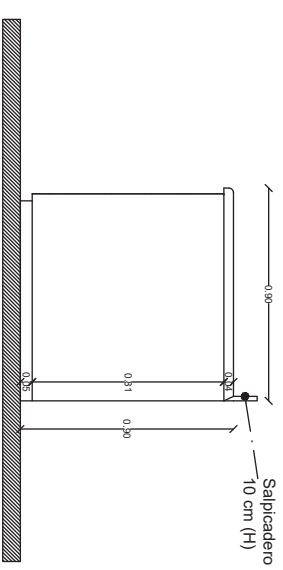

Mueble Exterior

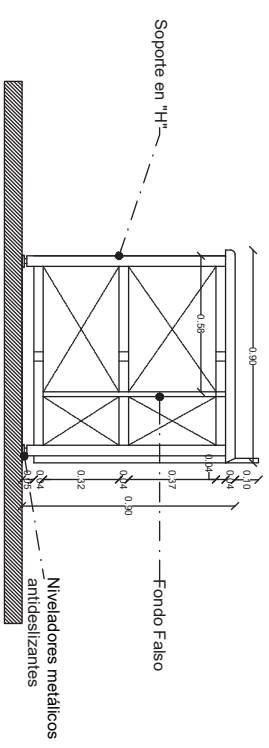

Mueble interior

ME 2.18

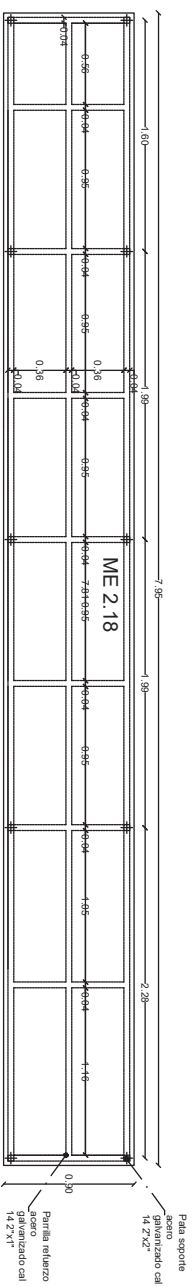

Planta soporte estructural superficie

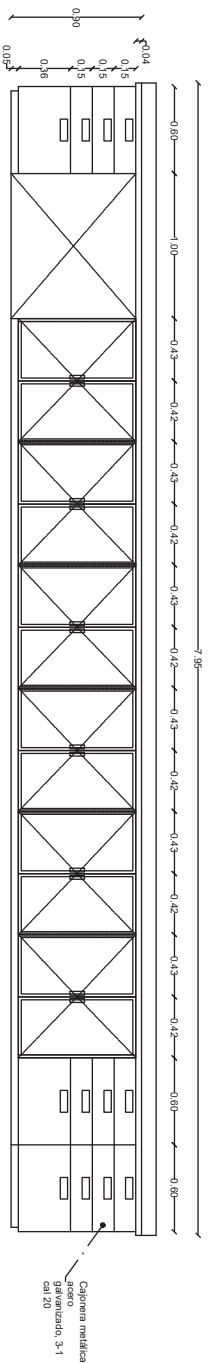

Mueble Cerrado

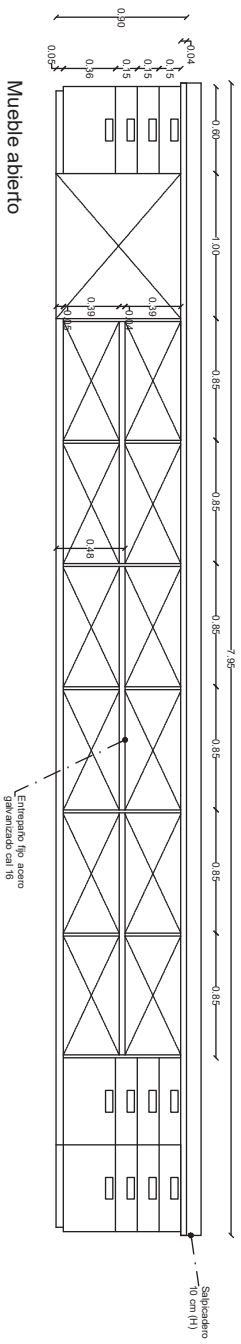

Mueble abierto

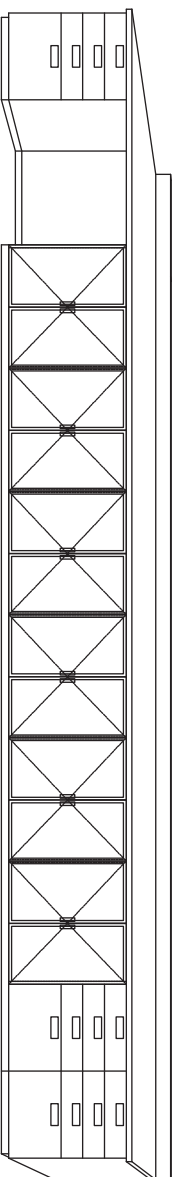

Mueble Exterior

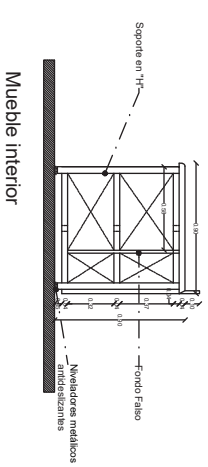

Mueble Interior

ME 2.19

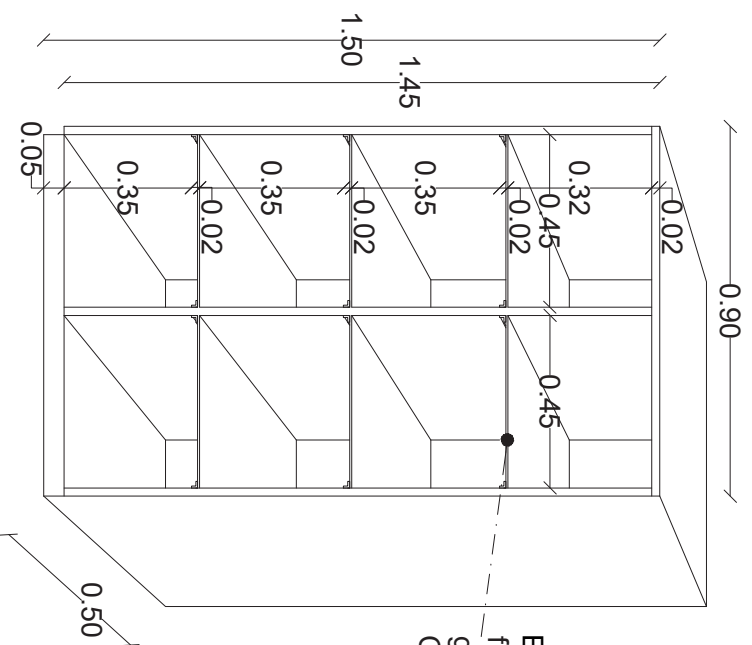

Detalle entrepaño soporte de bandejas

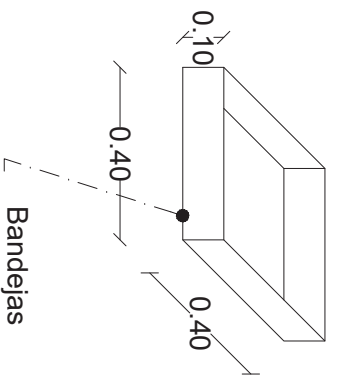
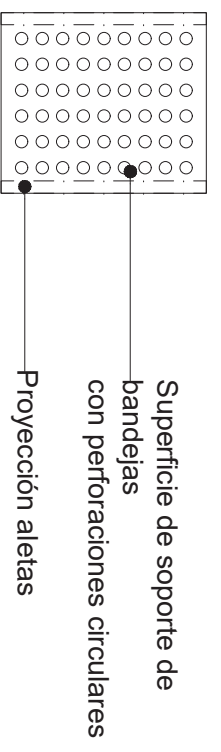
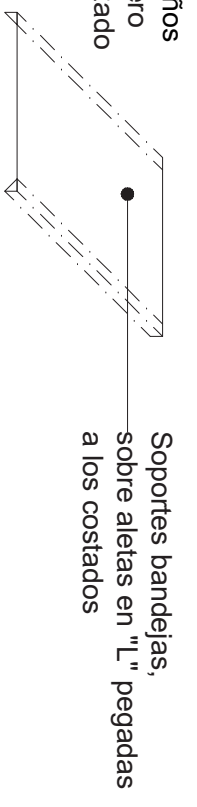

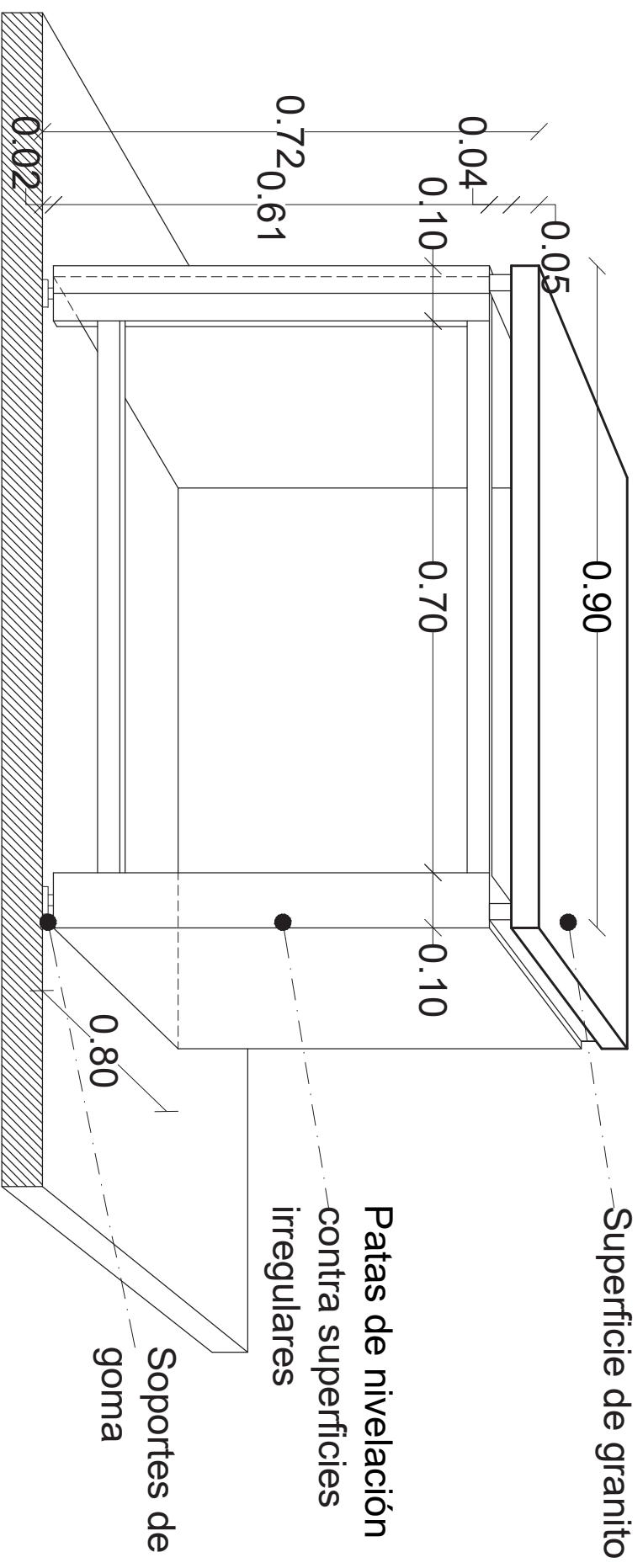

ME 2.23

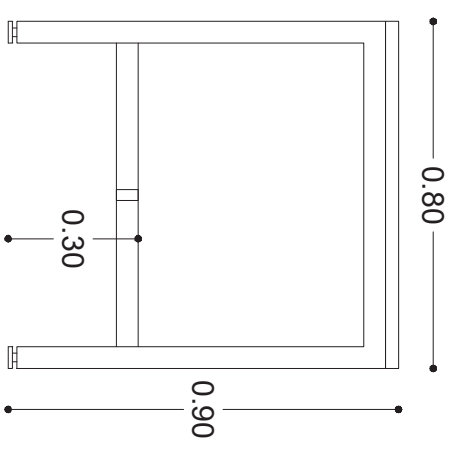
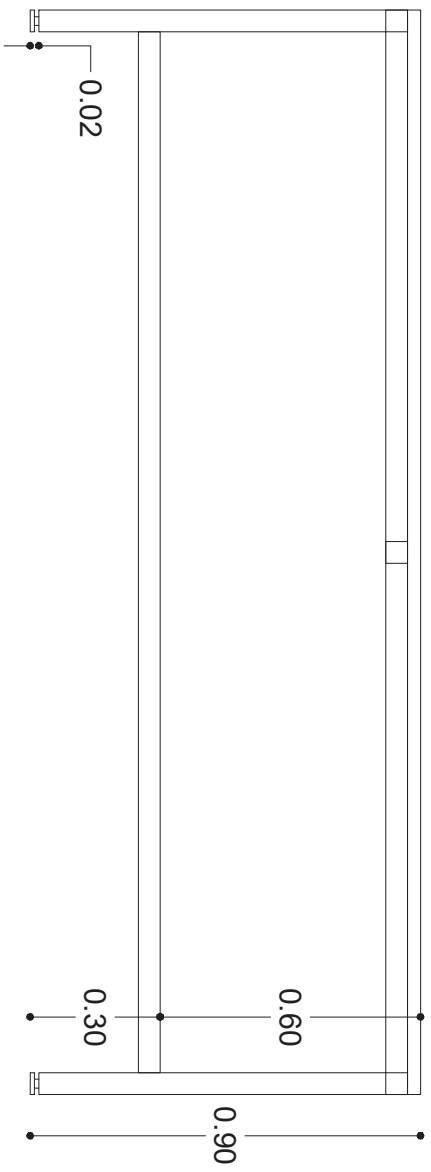
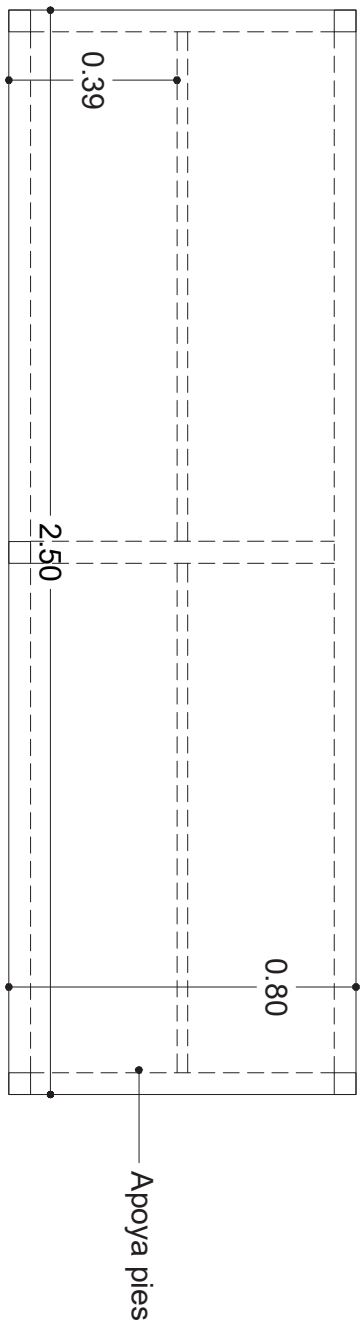

ME 2.24

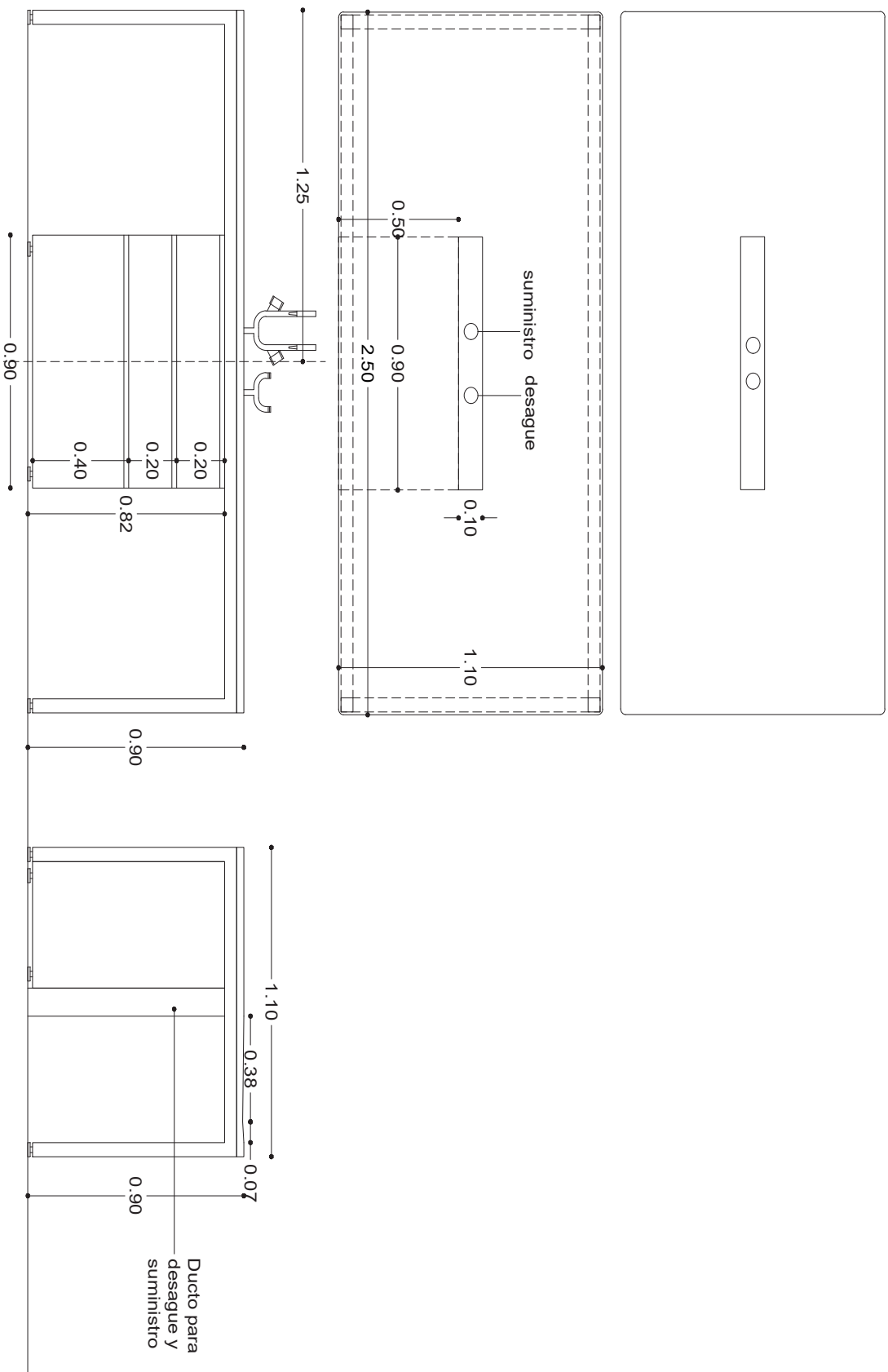

ME 2.25

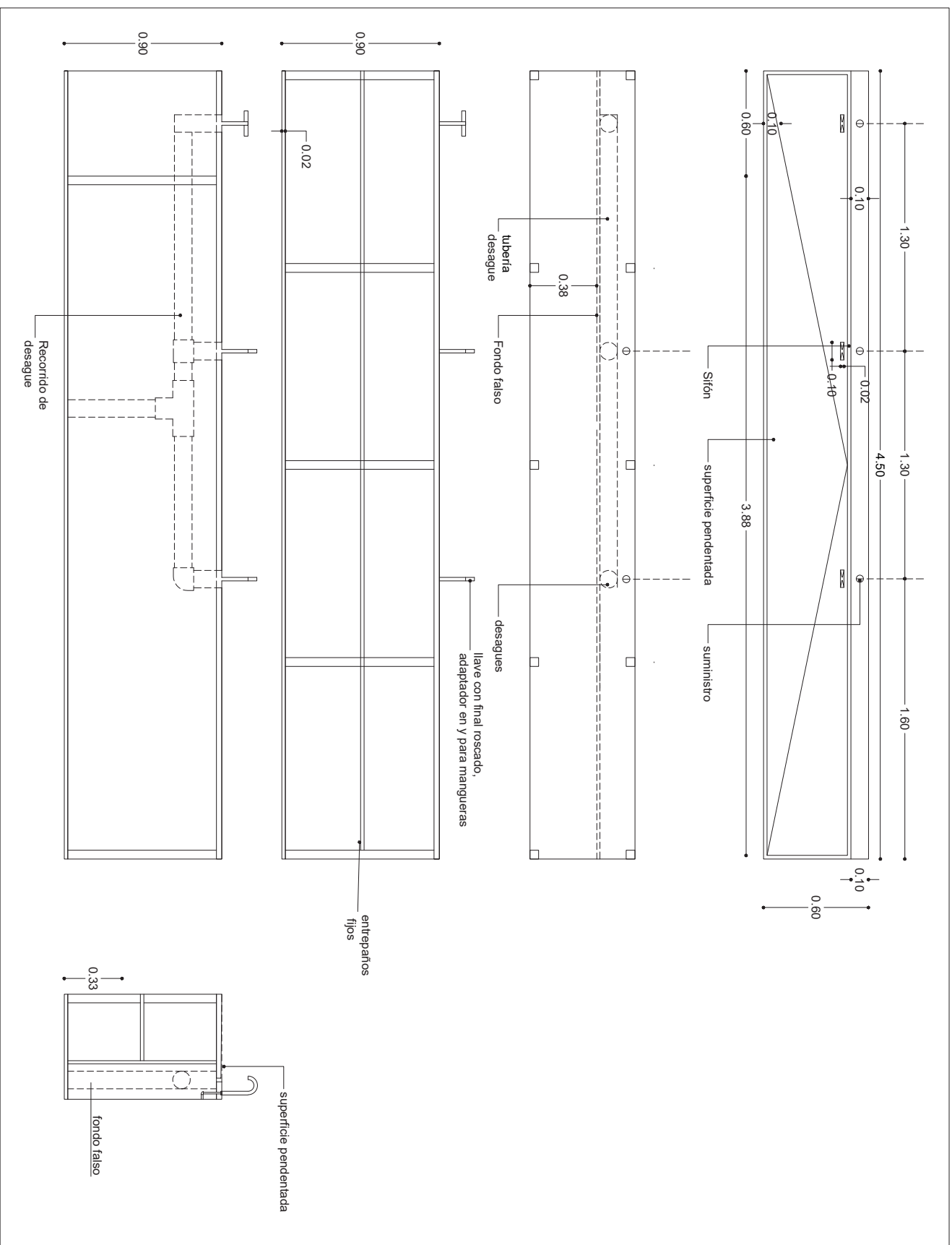

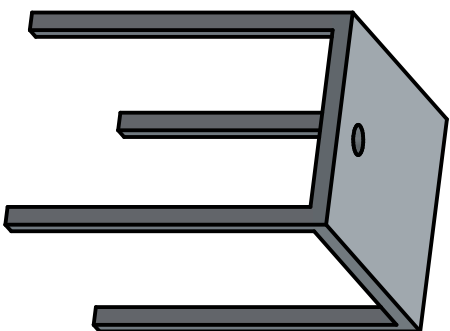
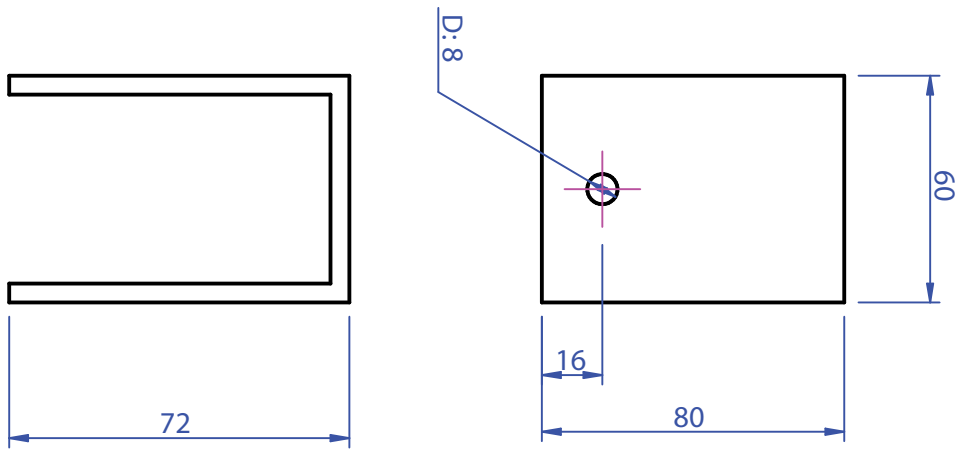

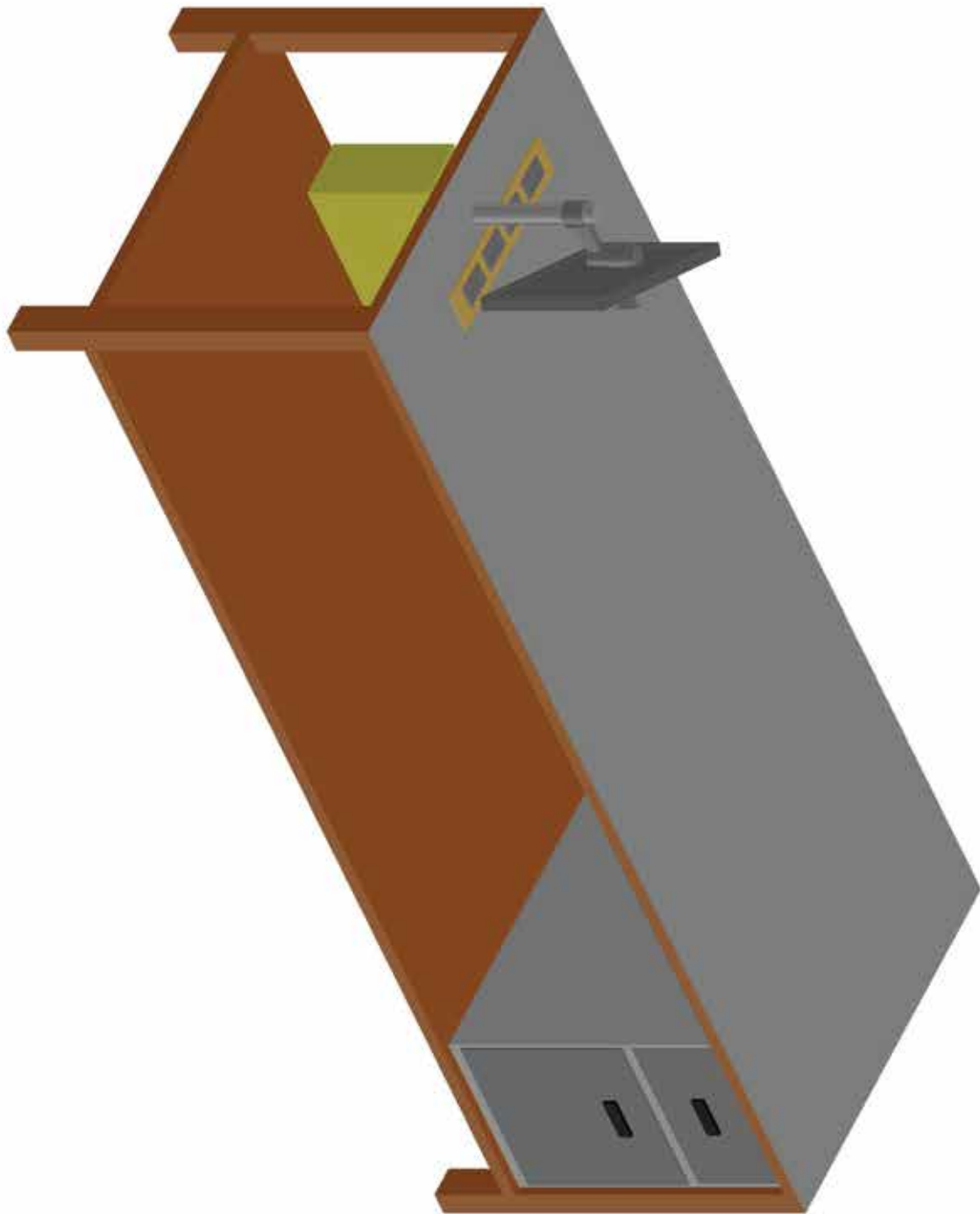

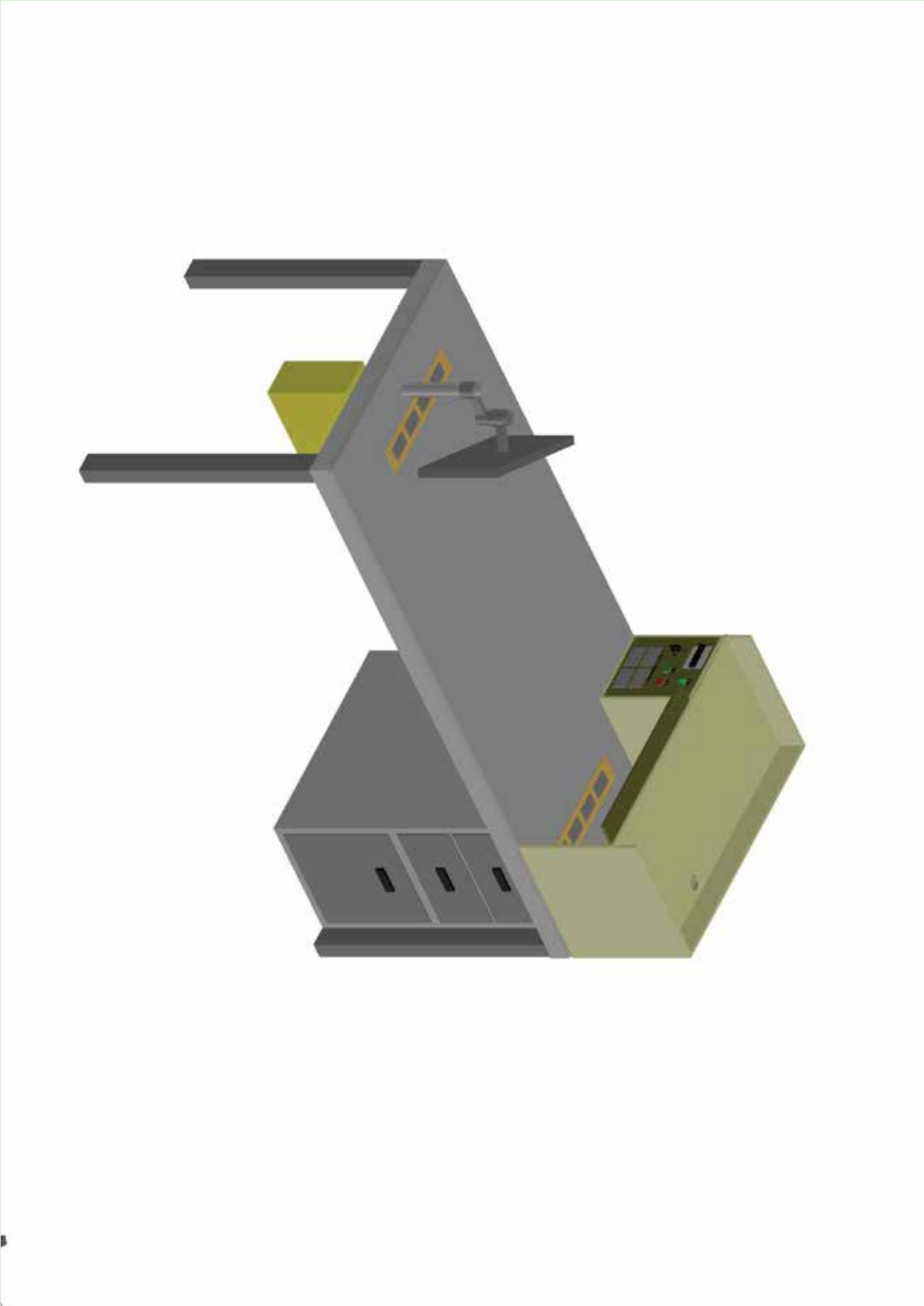

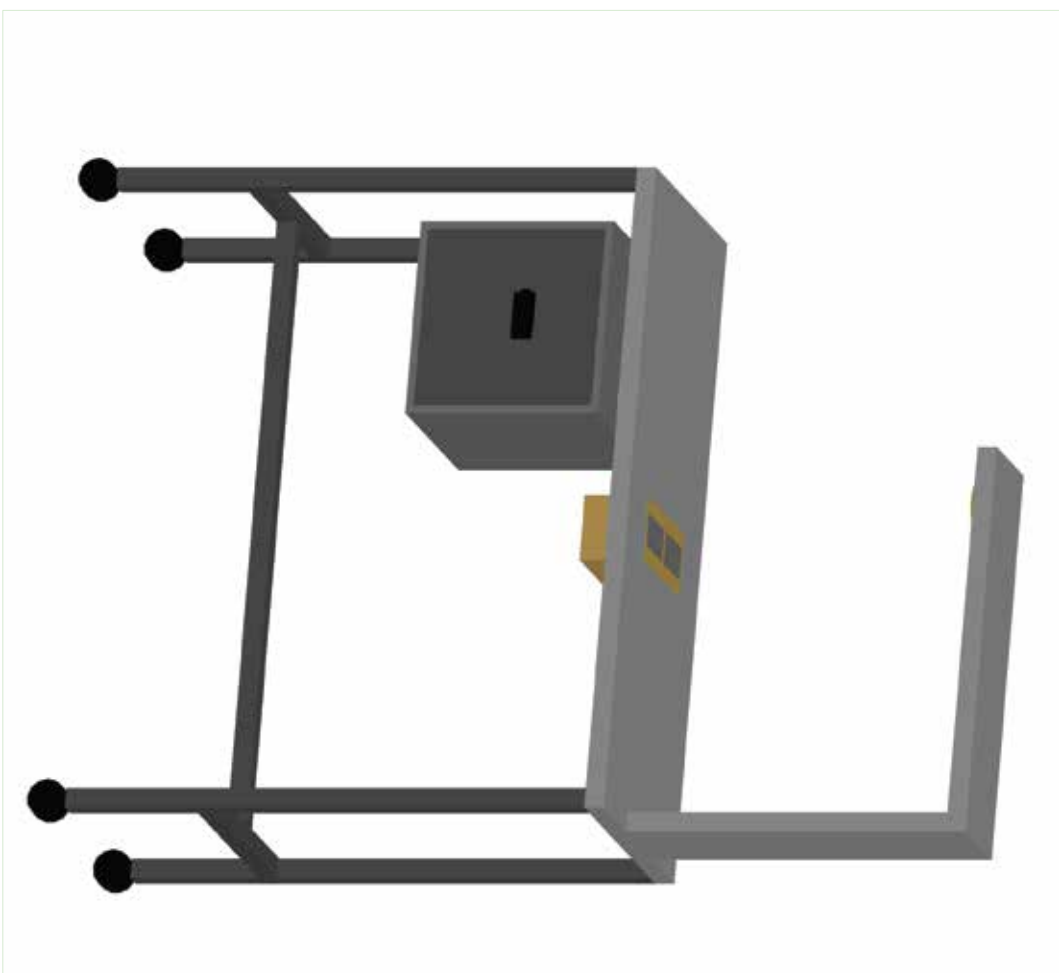
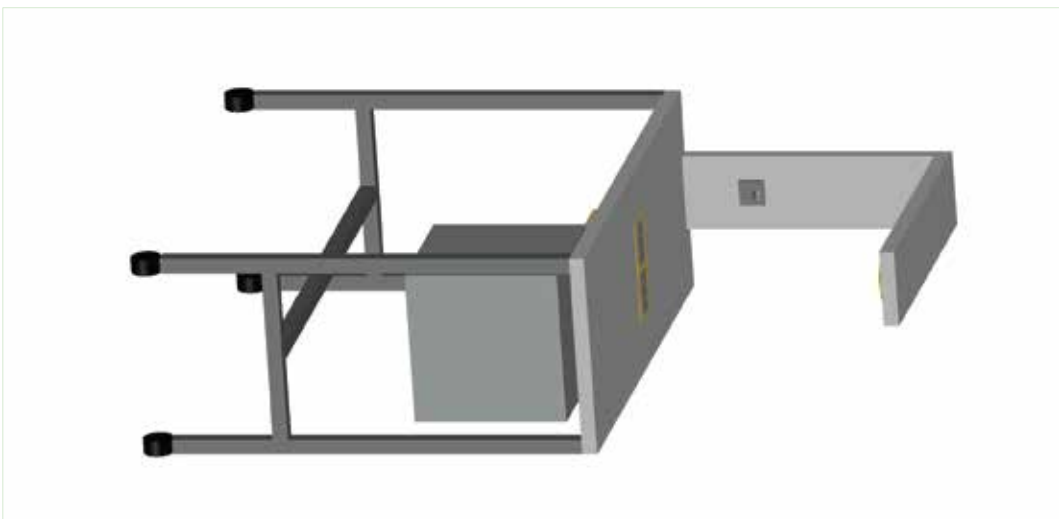

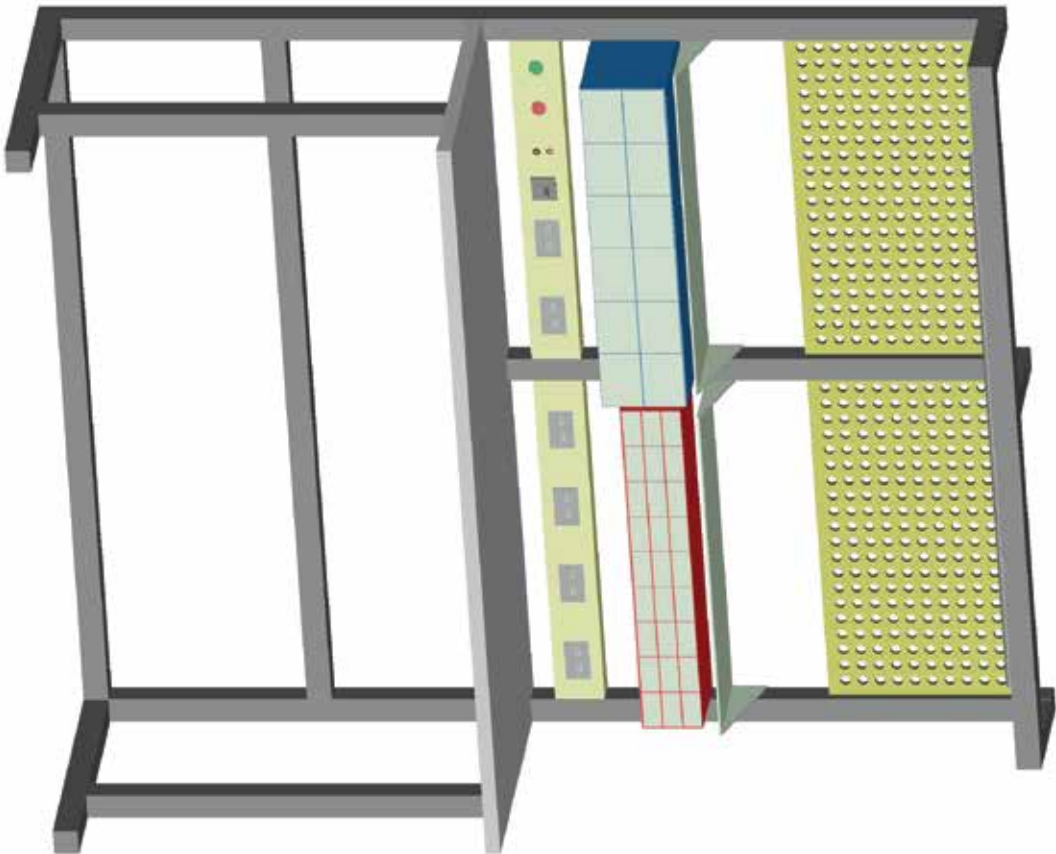
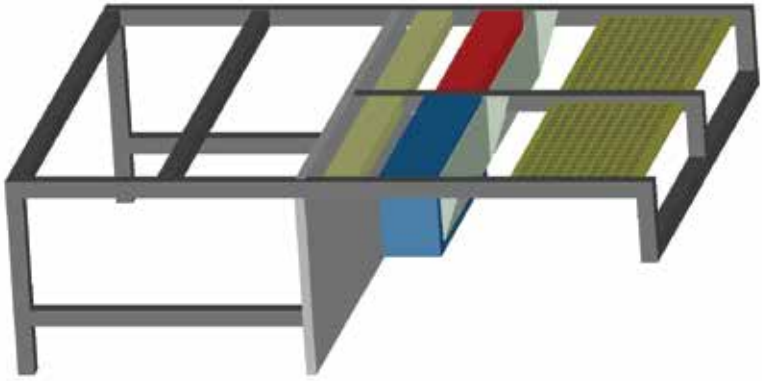

ME 2.33

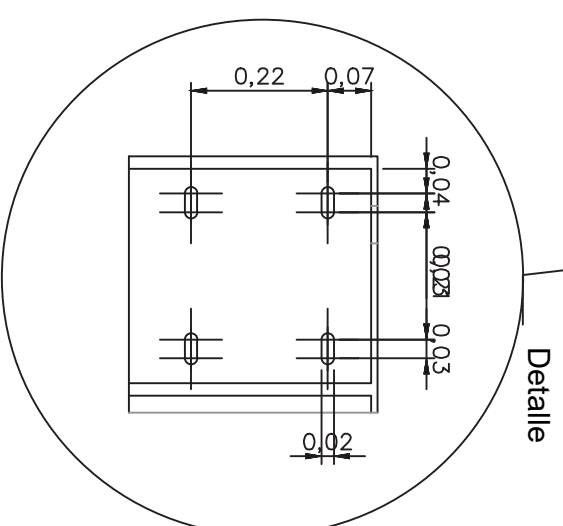
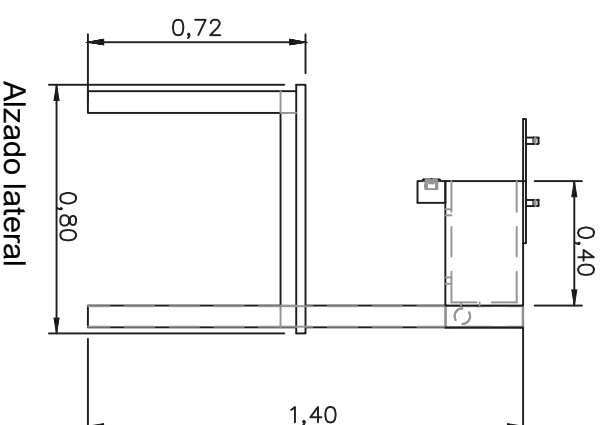
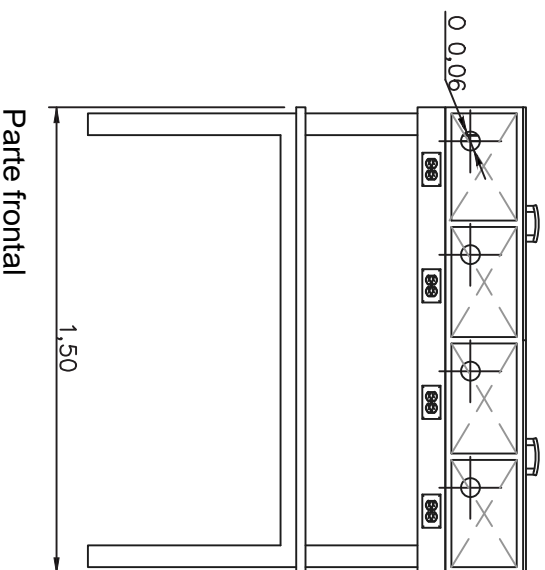
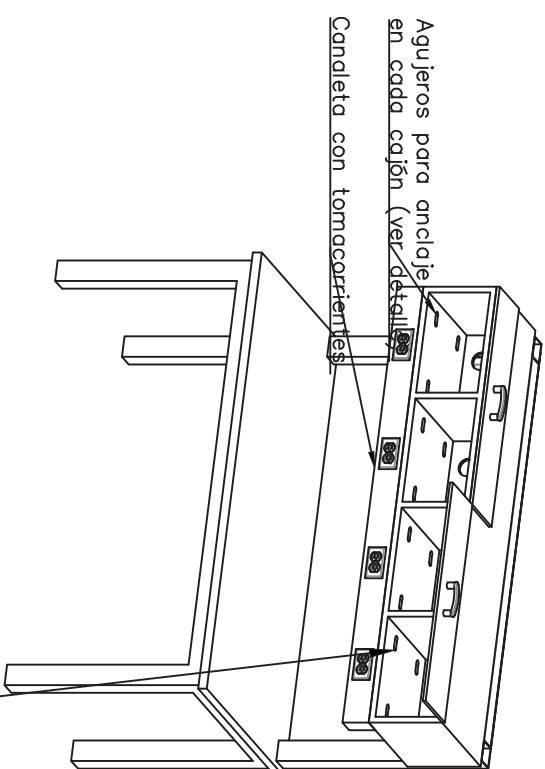
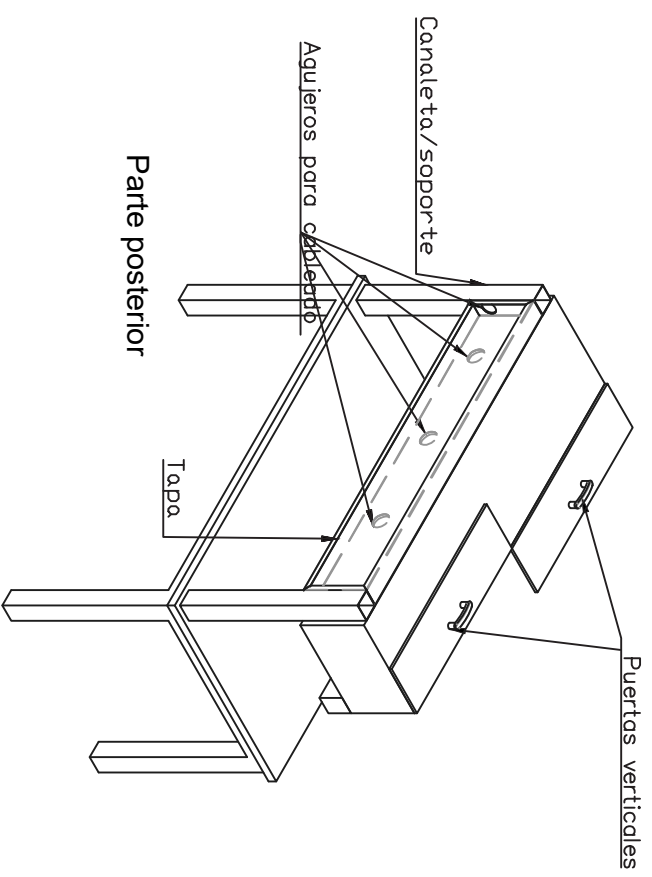

ME 2.34

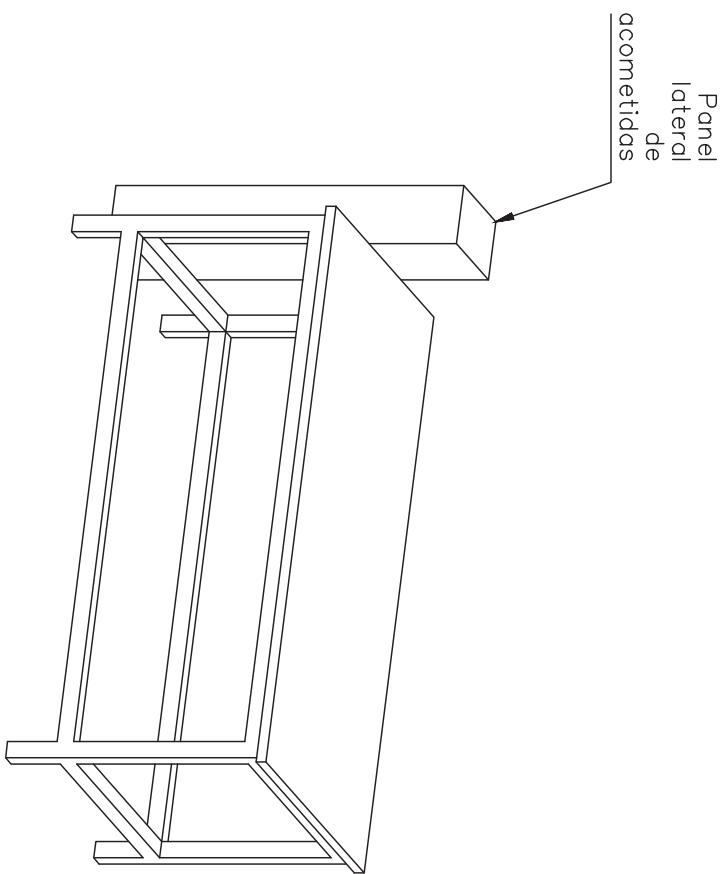
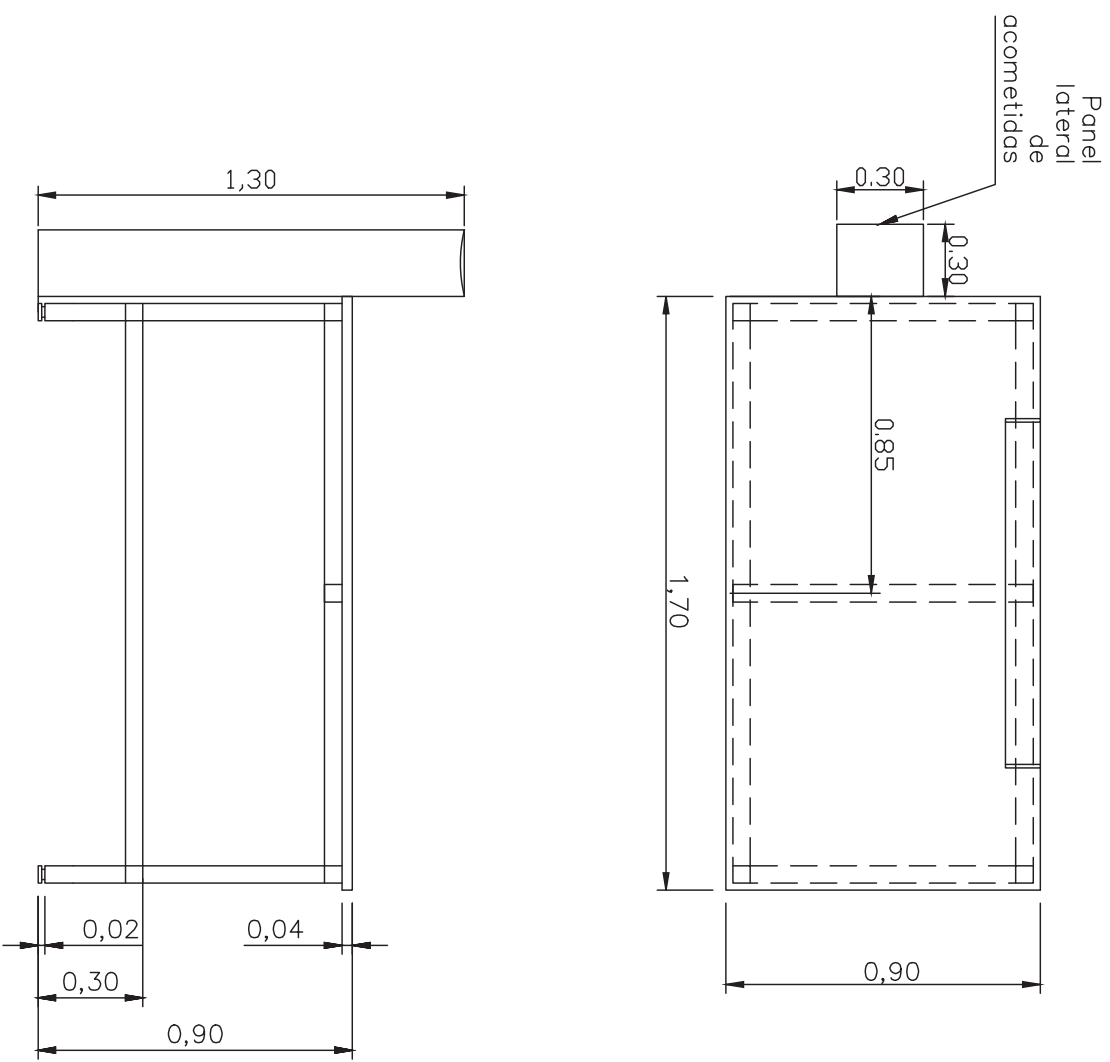

ME 2.35

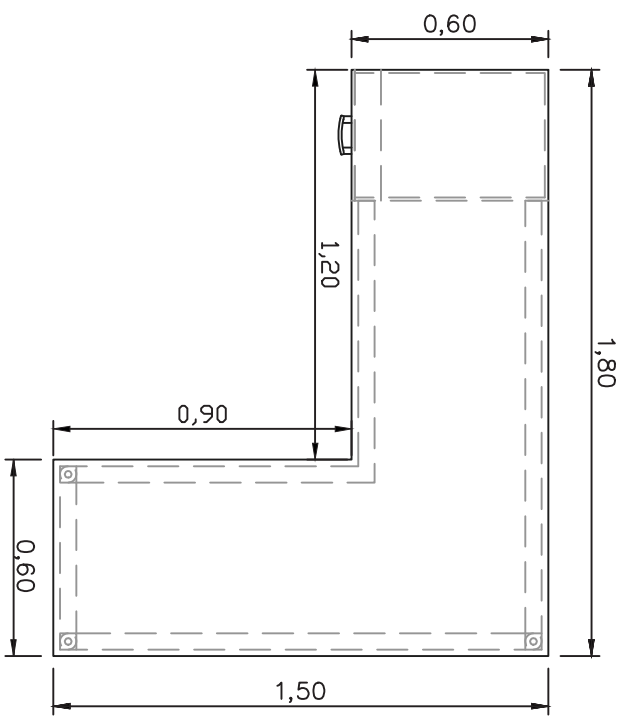
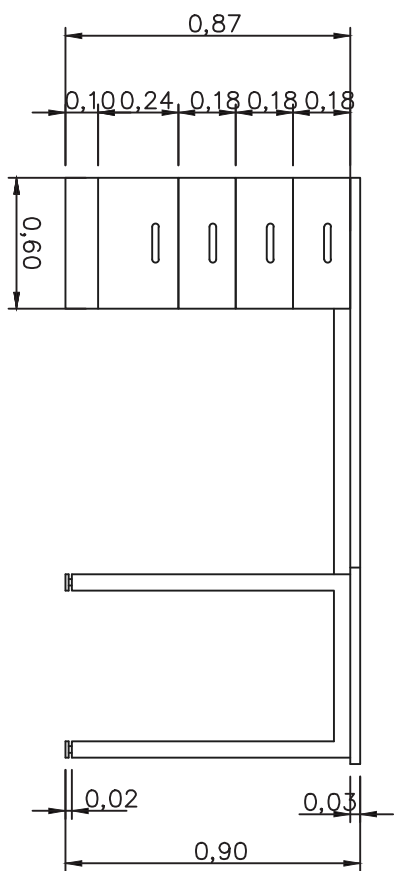

Superficie piedra sinterizada

Cajonera

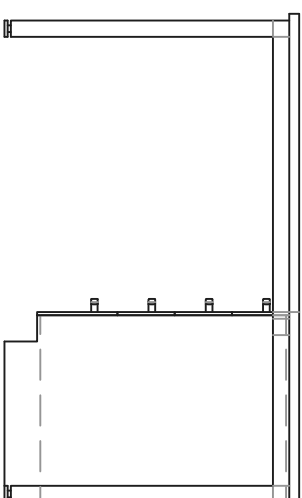
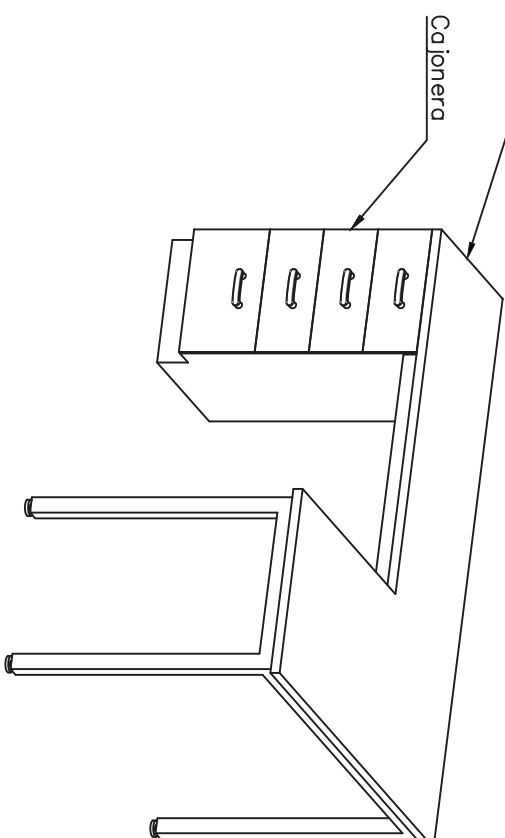

ME 2.36

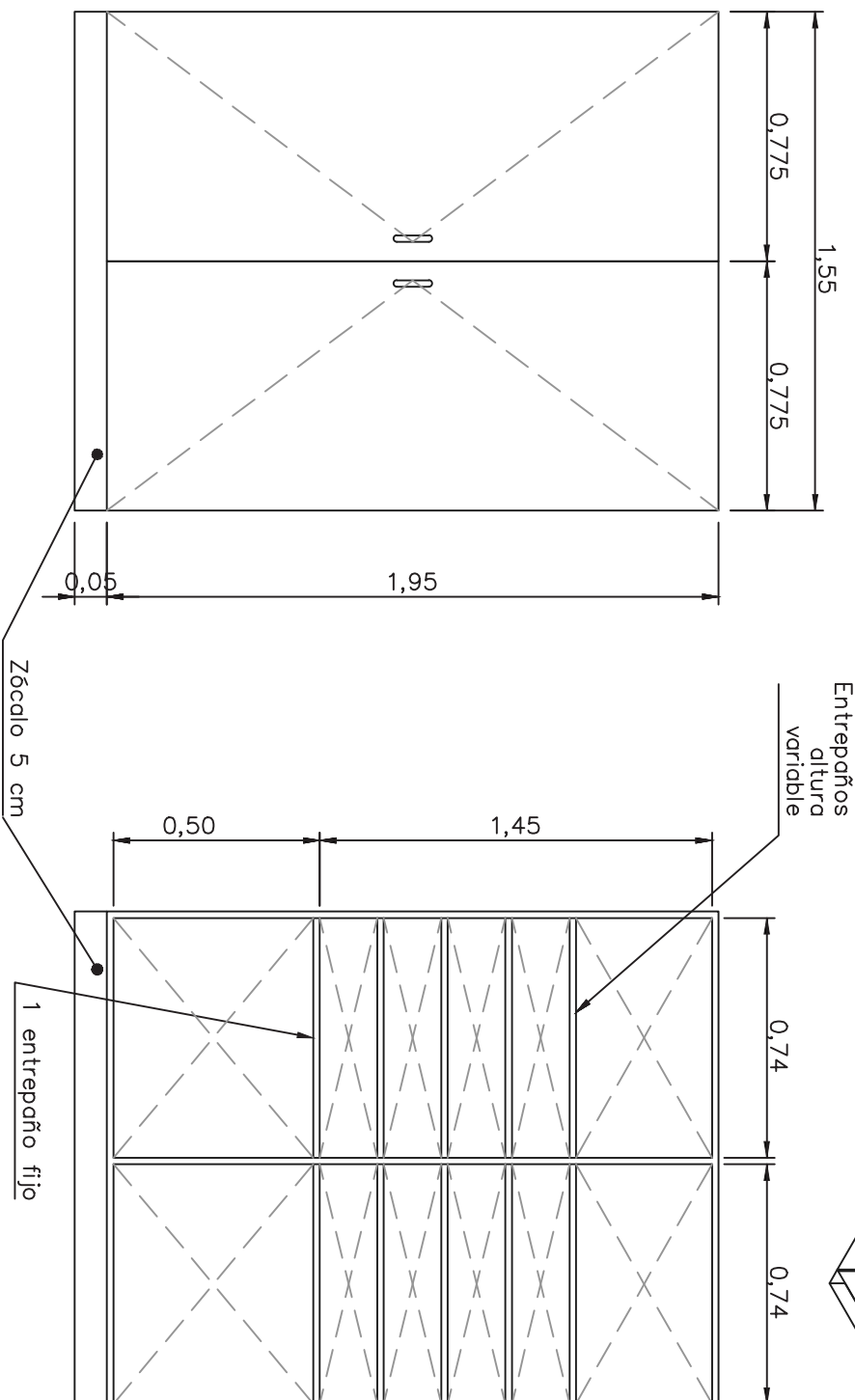
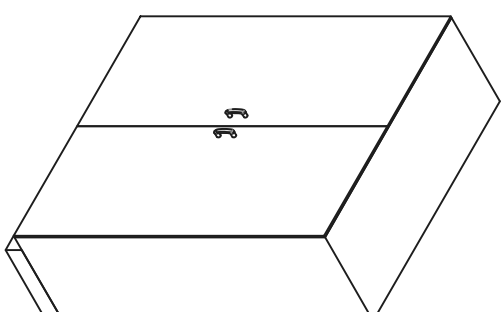
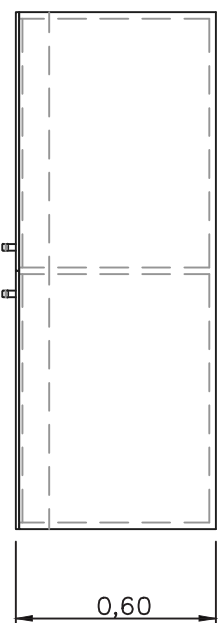

ME 2.37

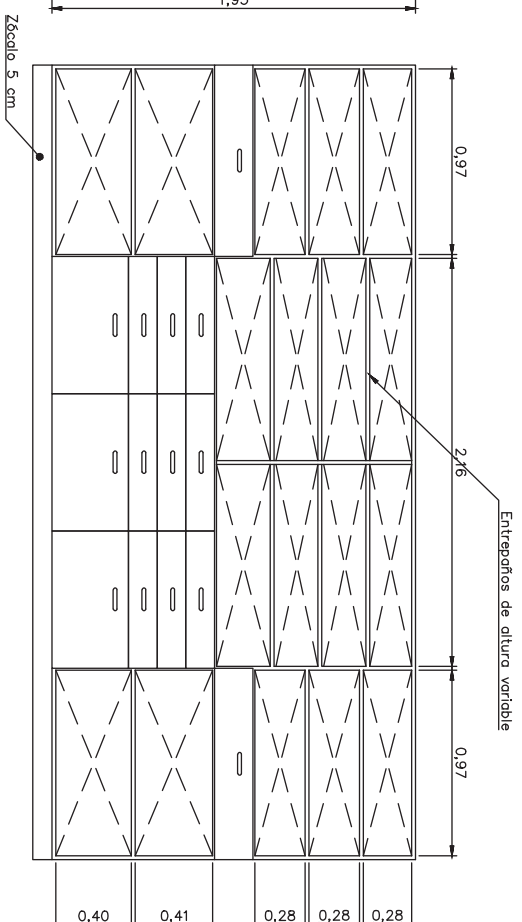
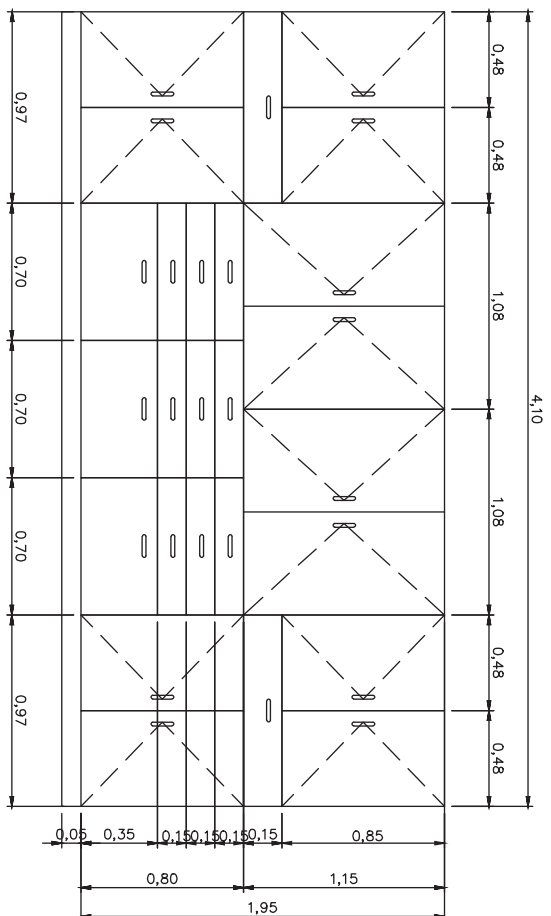
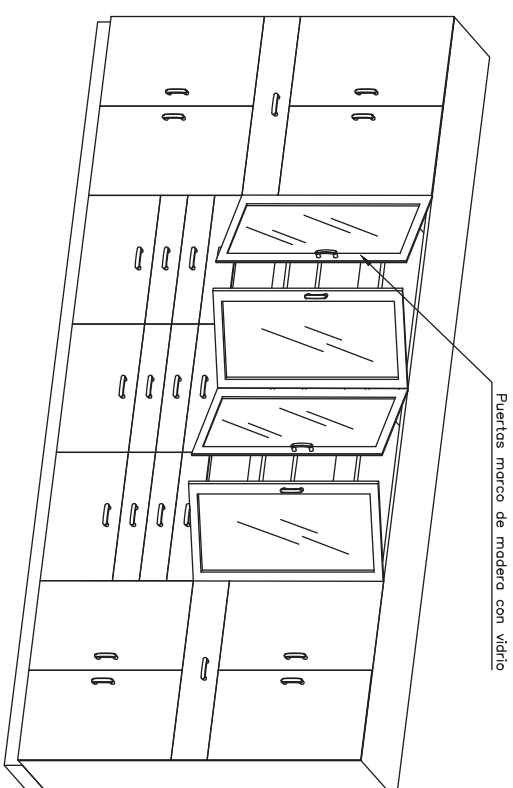
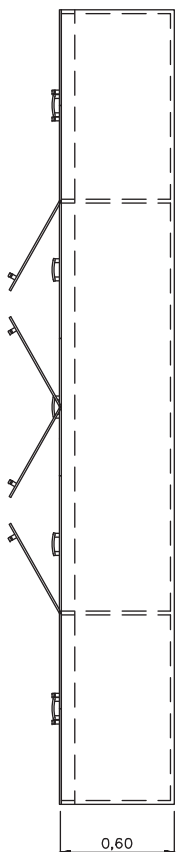

ME 2.38

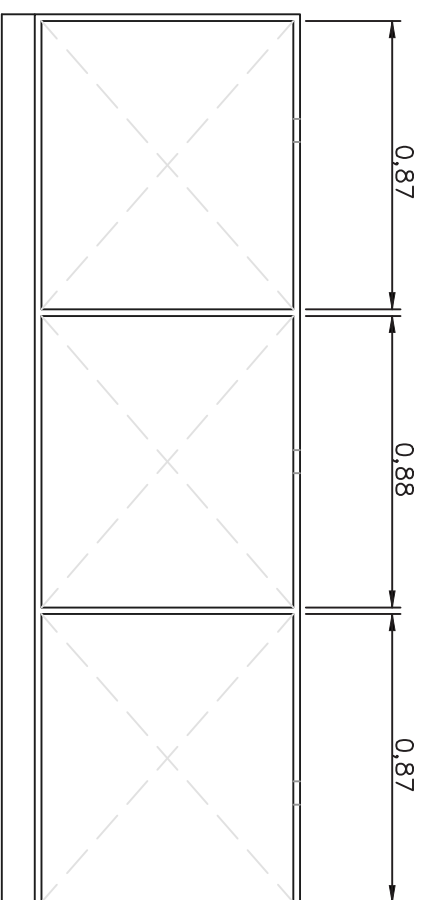
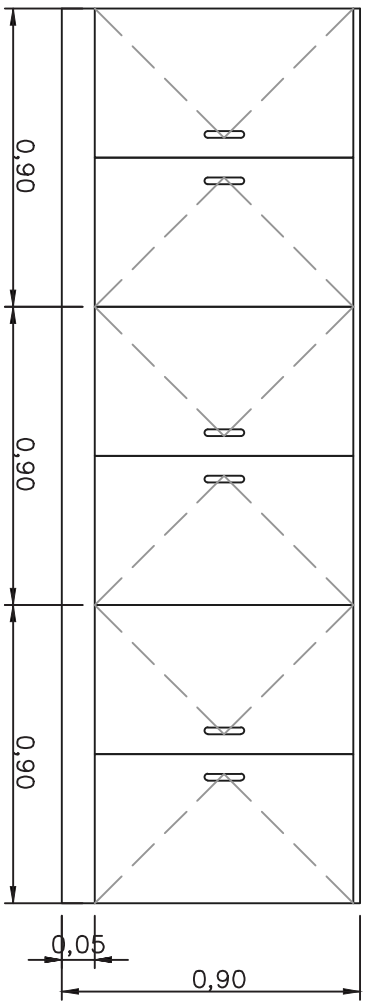
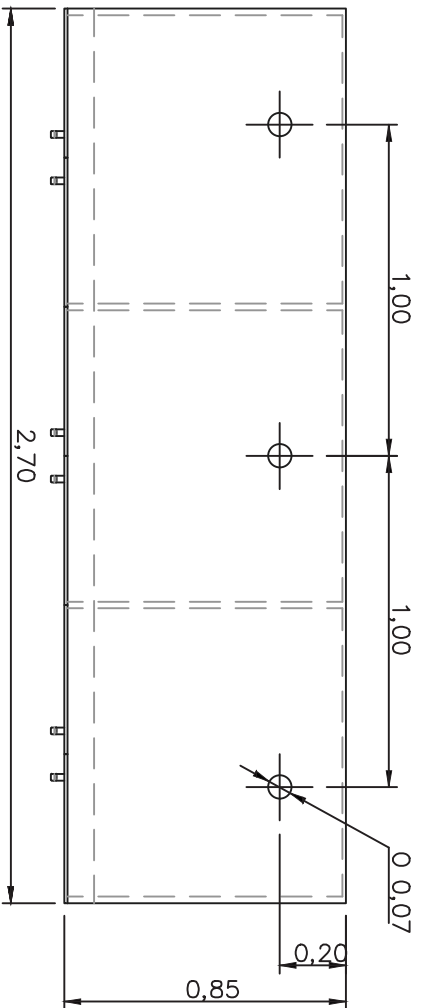
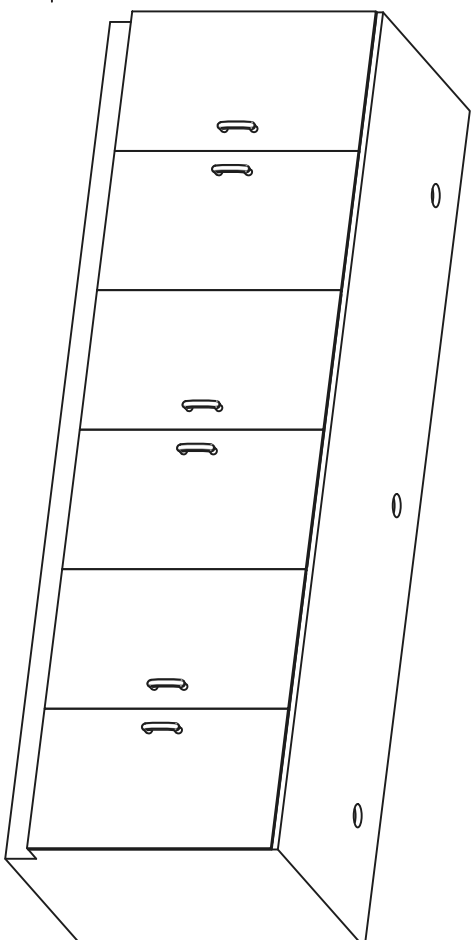

ME 2.39

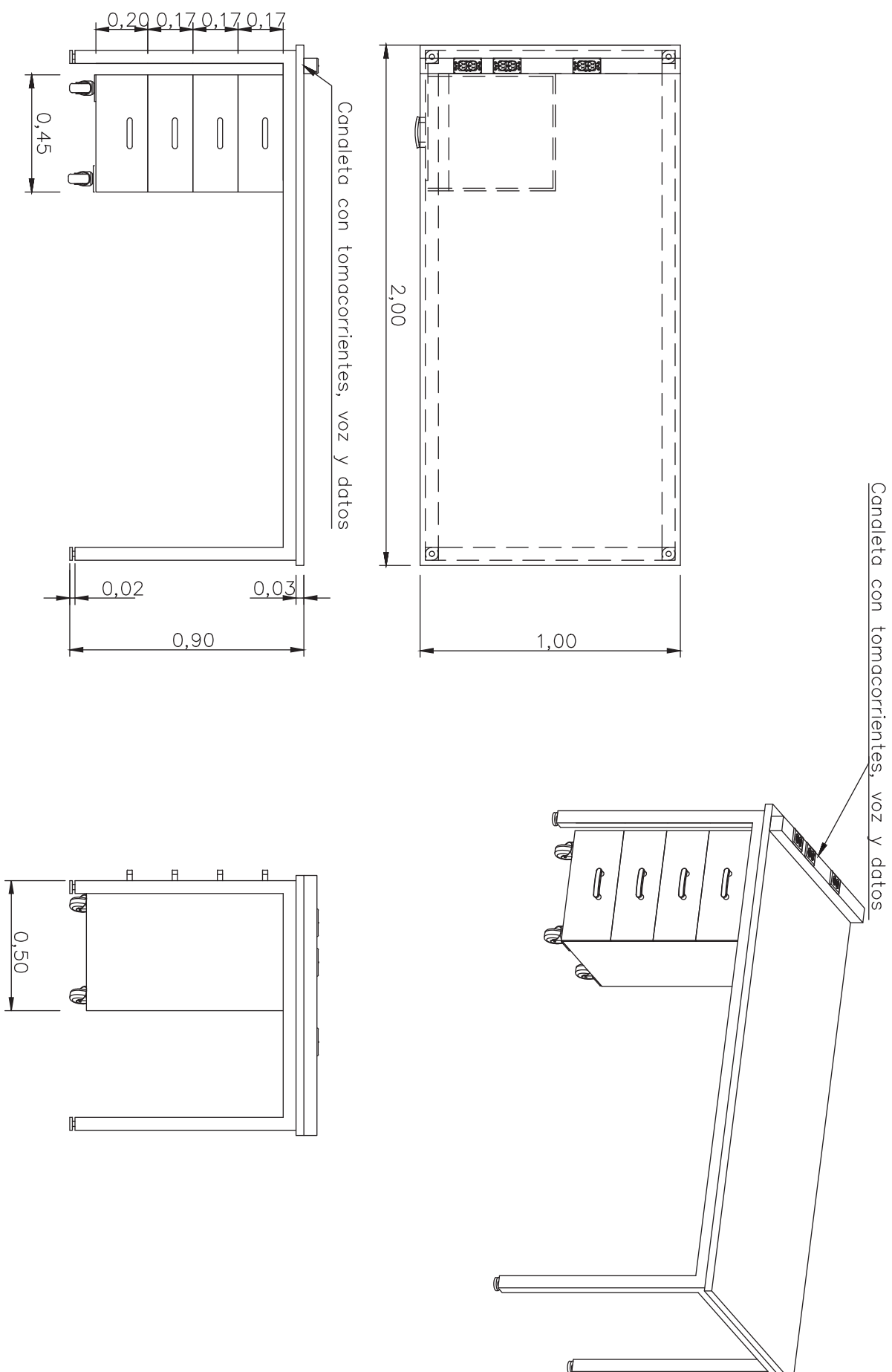

ME 2.40

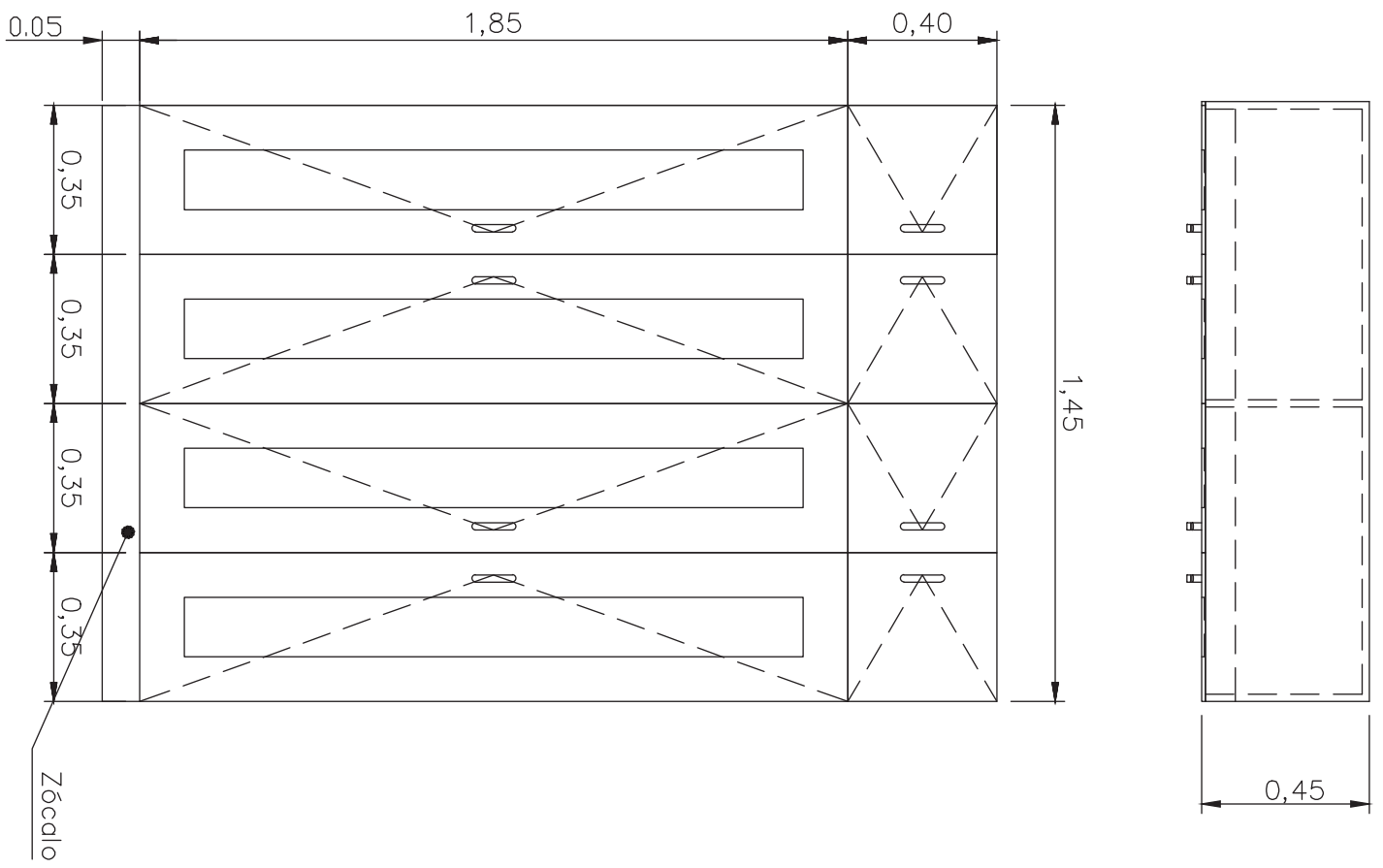

ME 2.41

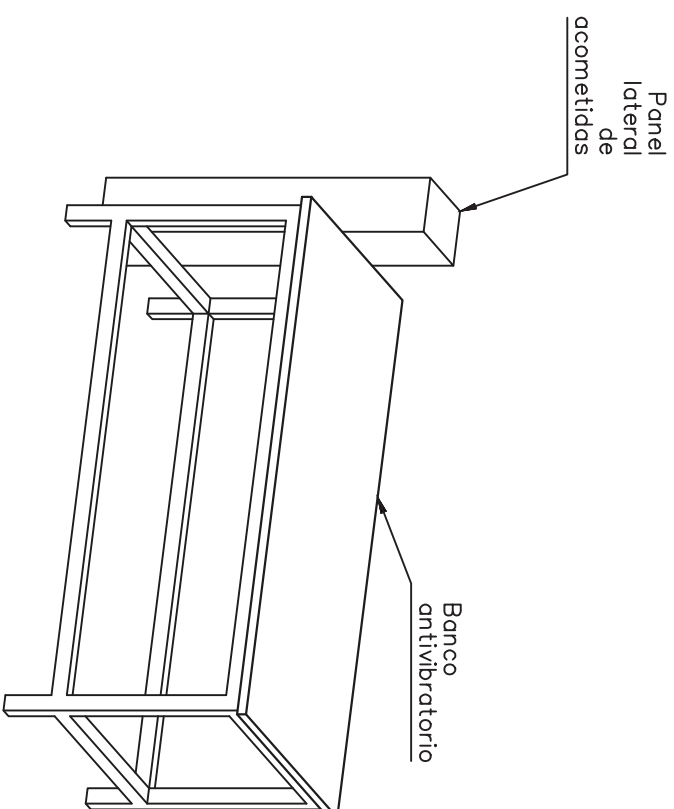
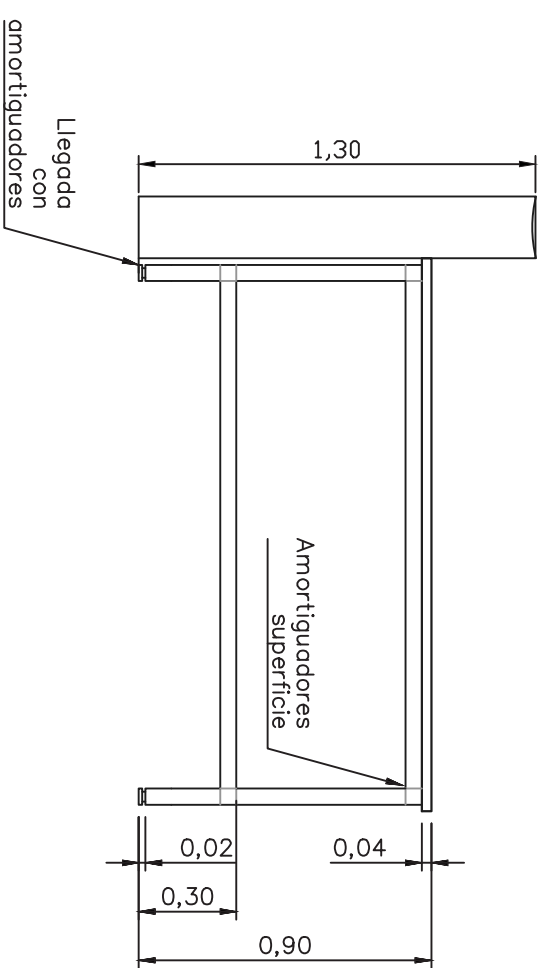
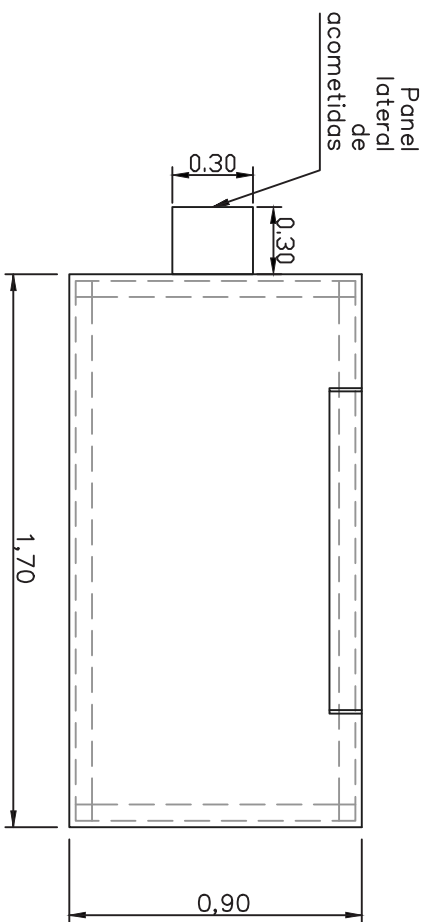

ME 2.42

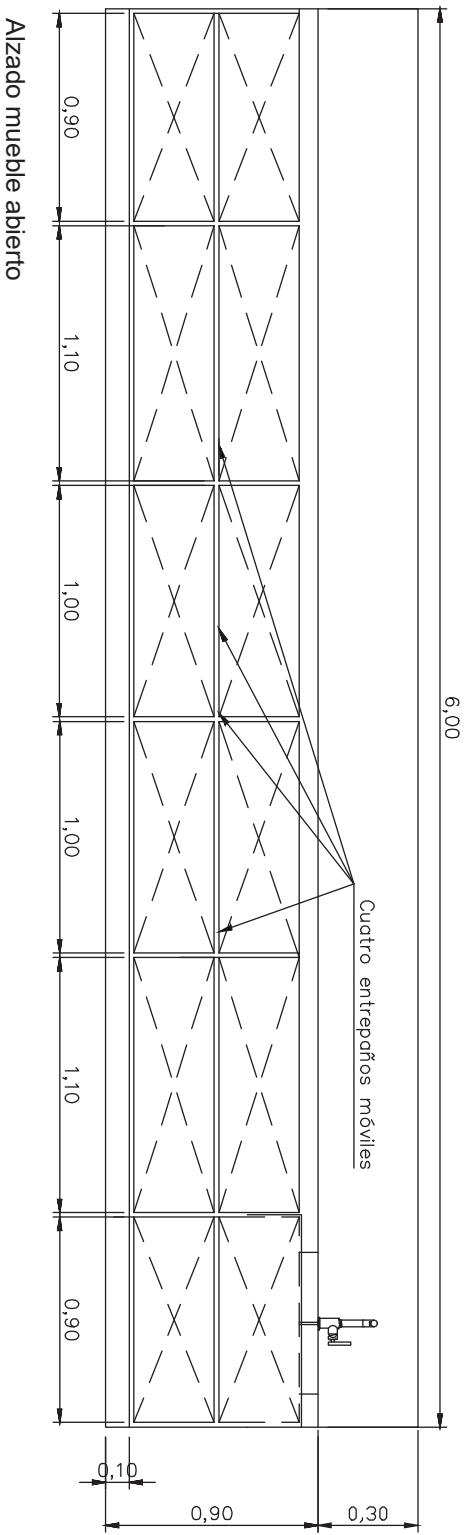
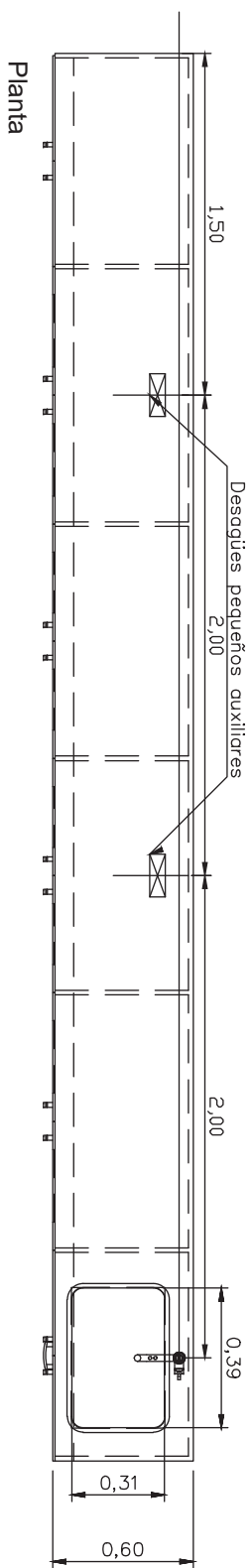
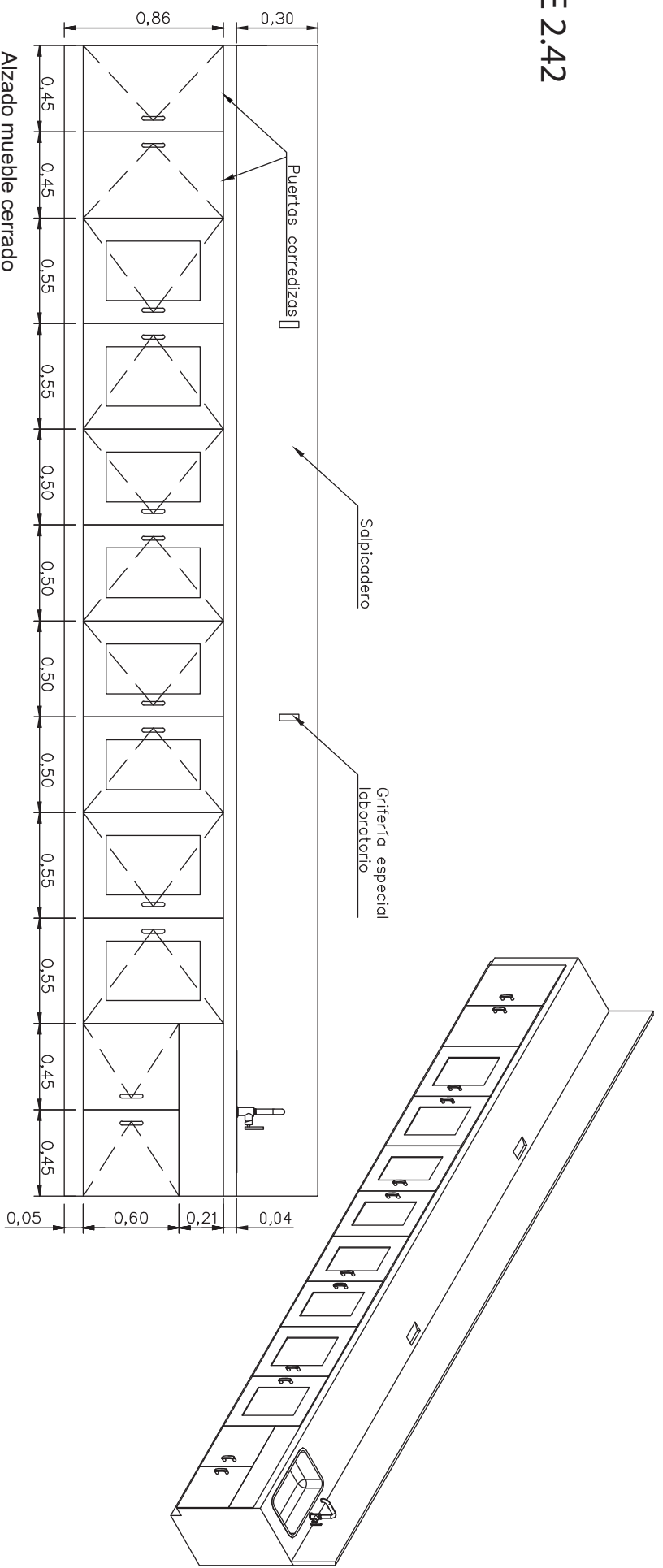

ME 2.43

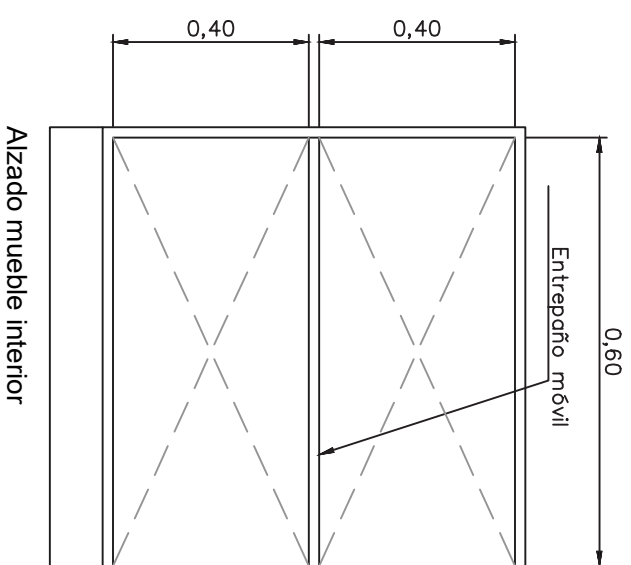
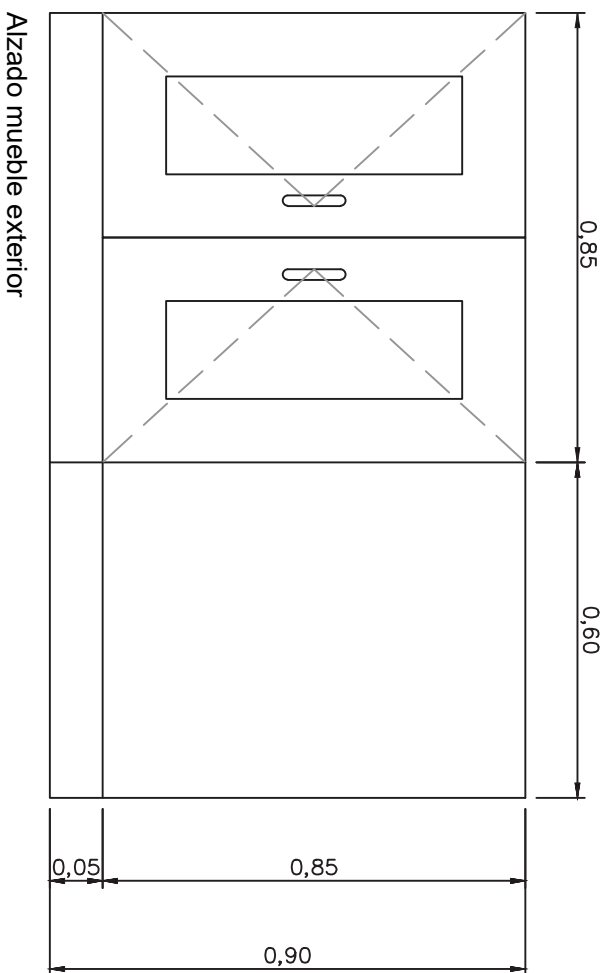
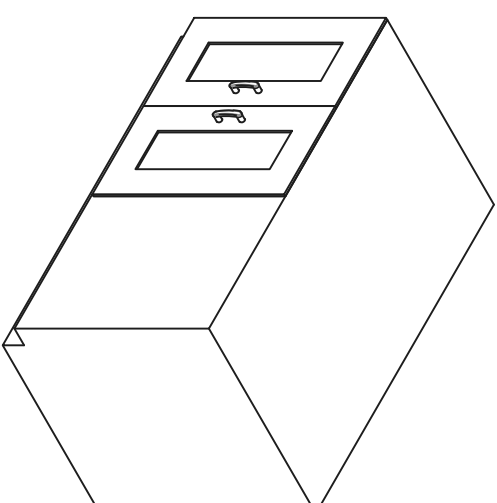
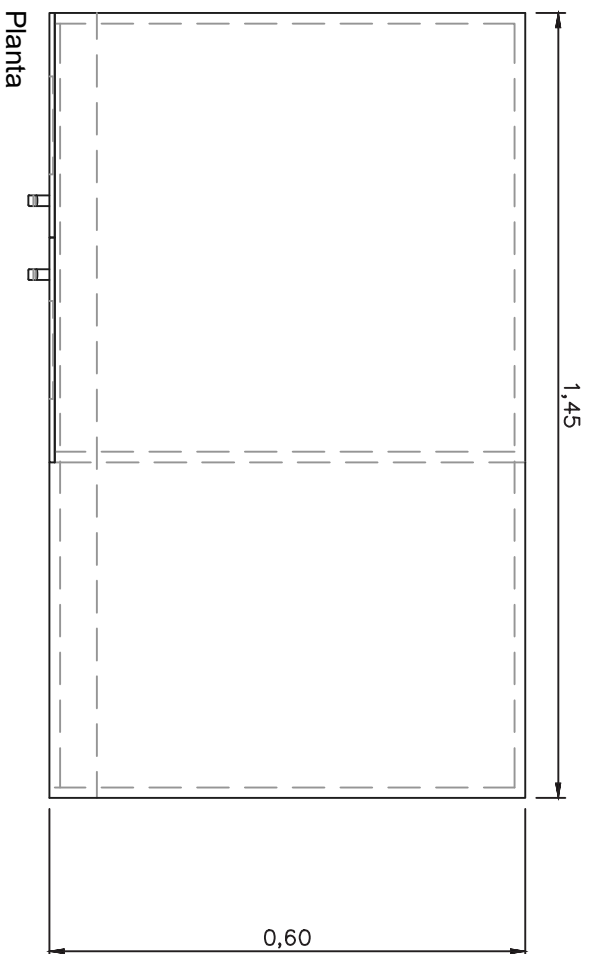

ME 2.44

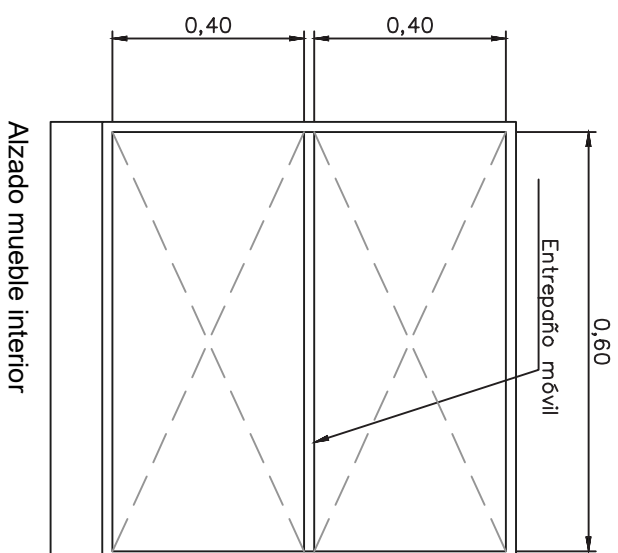
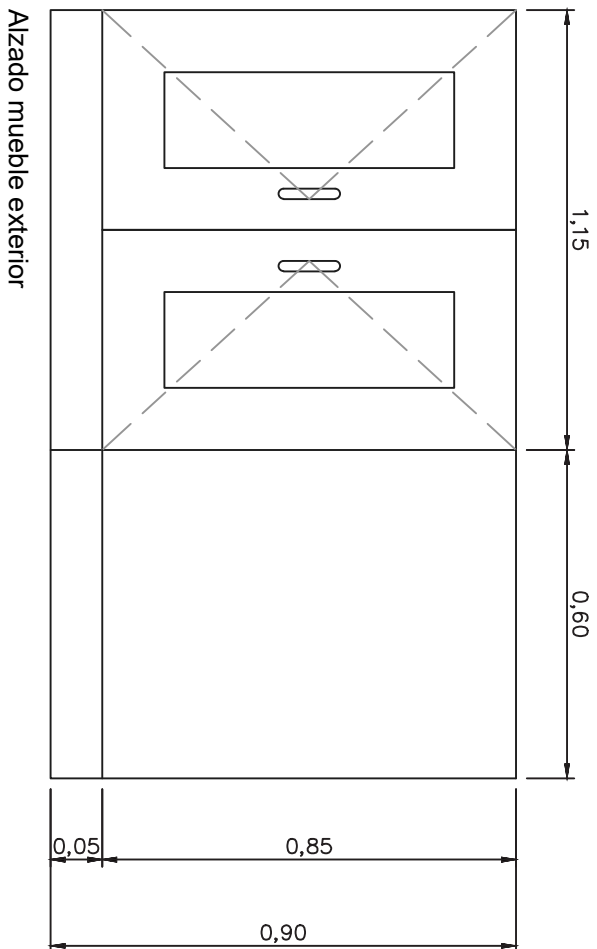
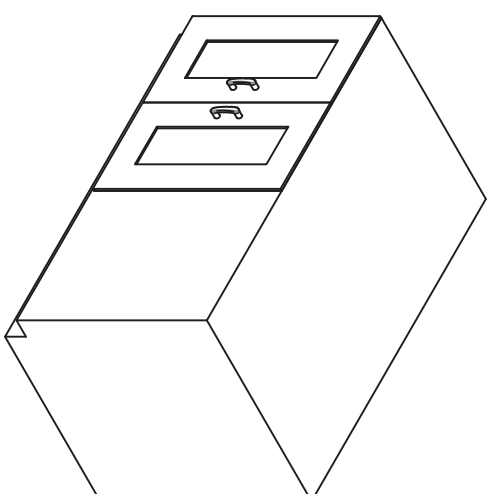
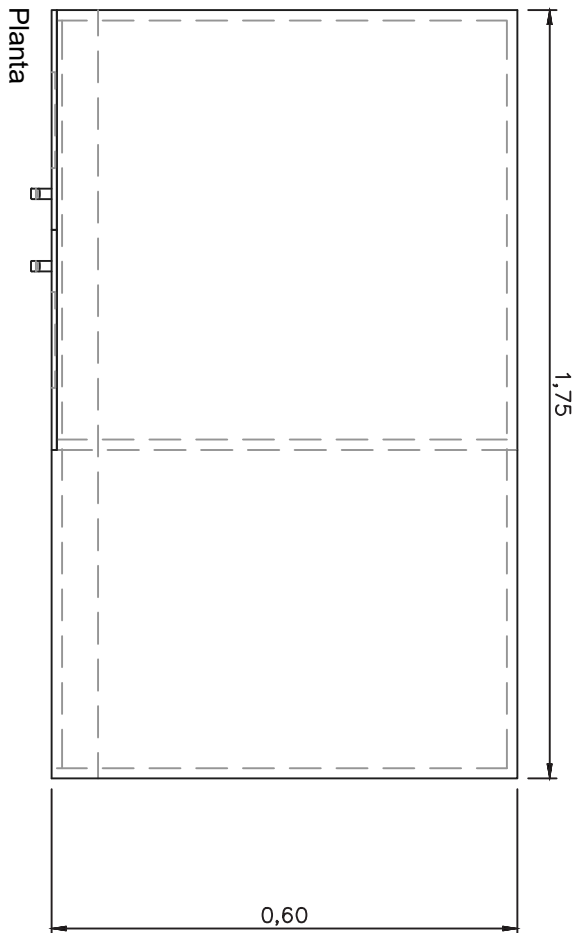

ME 2.45

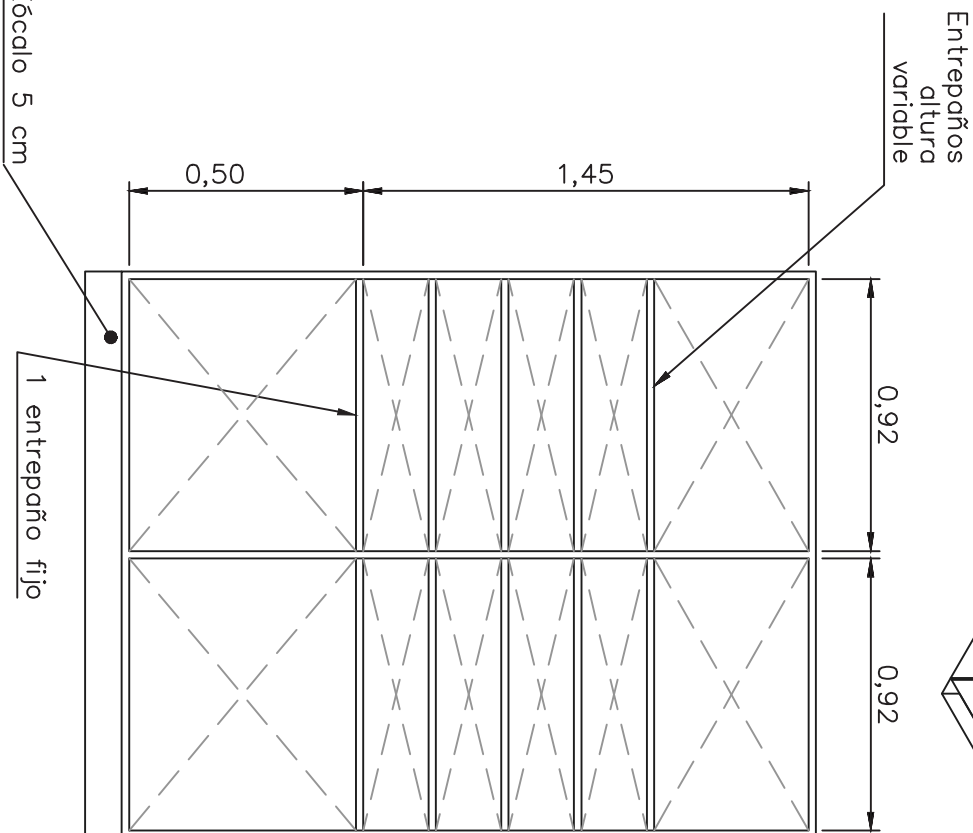
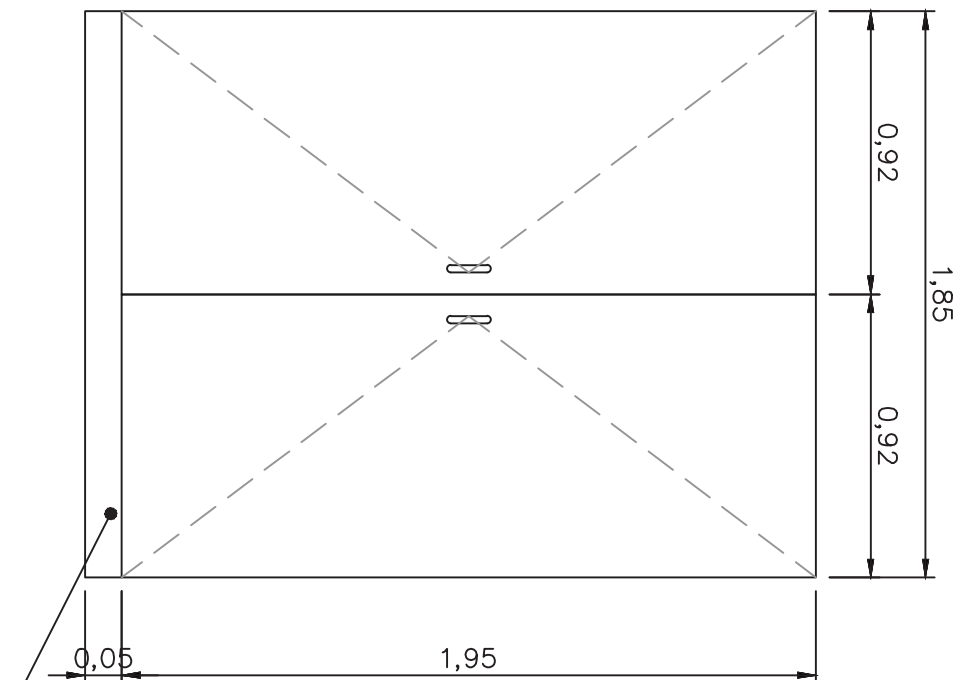
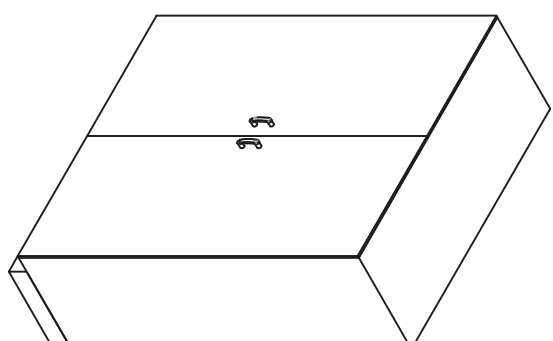
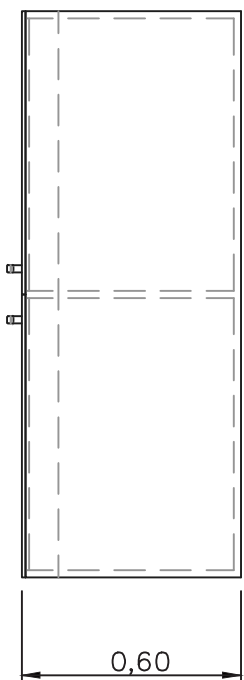

ME 2.46

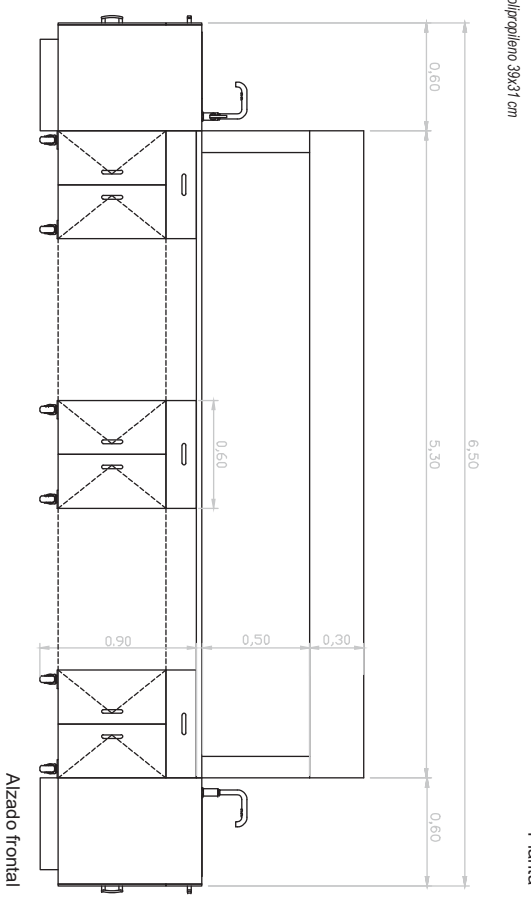
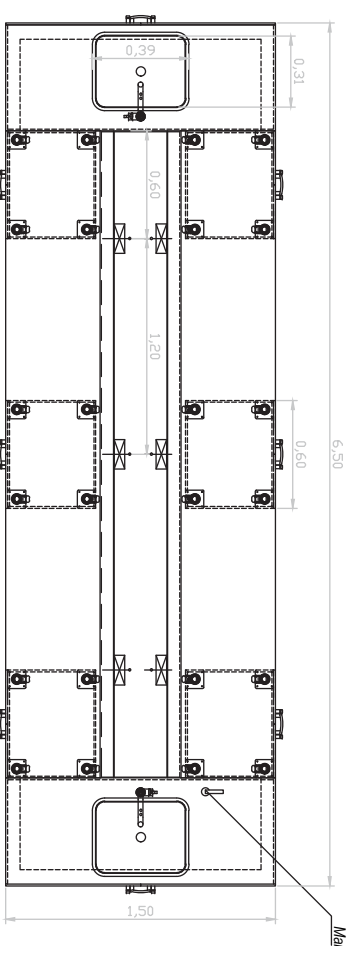
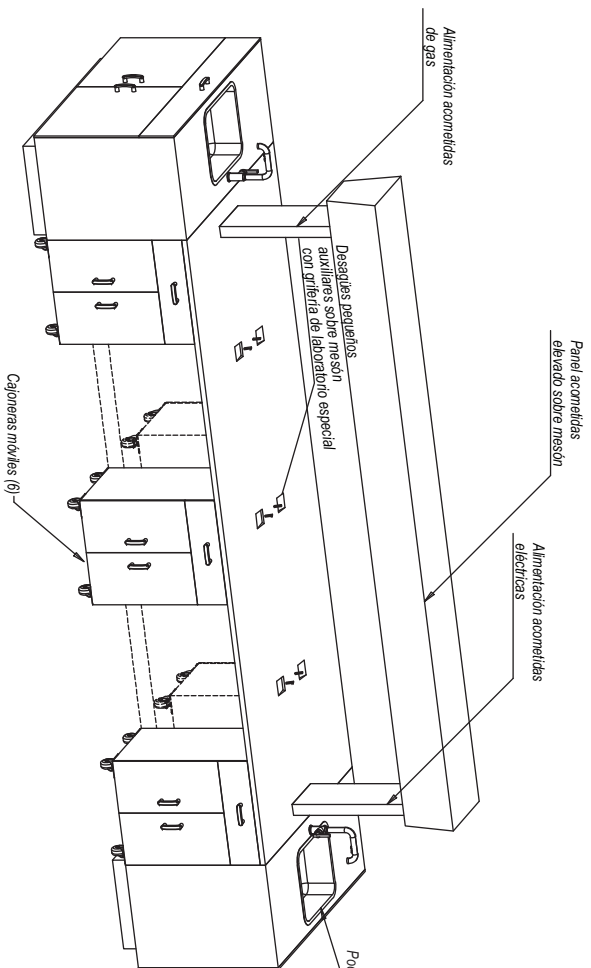

ME 2.47

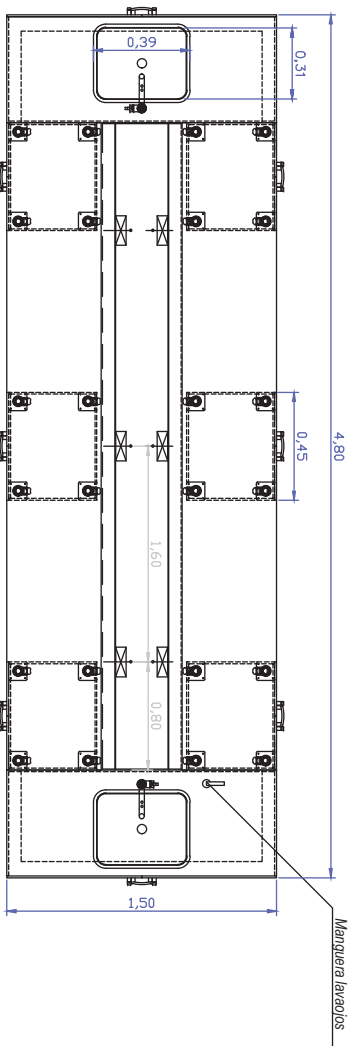

Planta

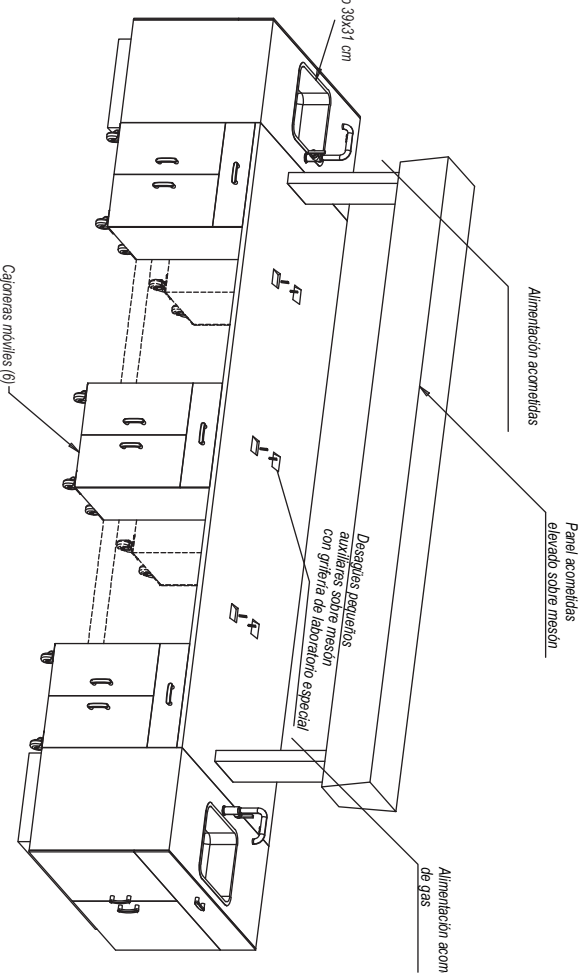
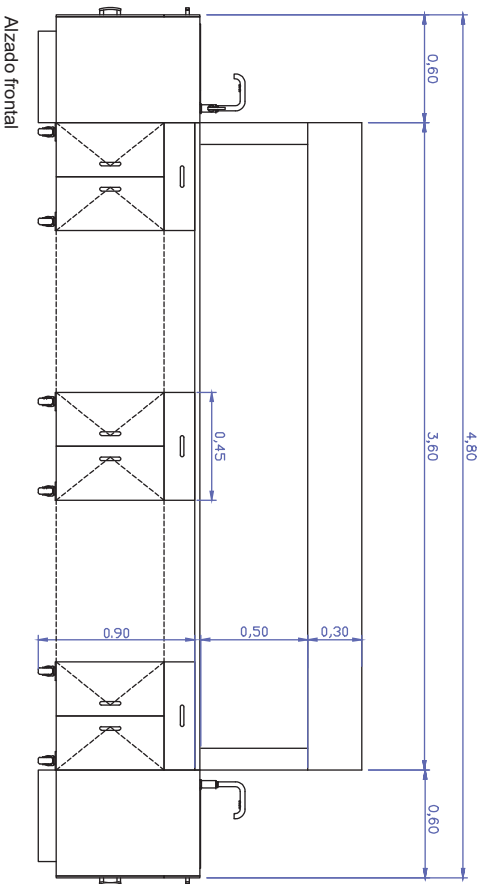

ME 2.48

SOLO ESPECIFICACIÓN TÉCNICA

SOLO ESPECIFICACIÓN TÉCNICA

ME 2.50

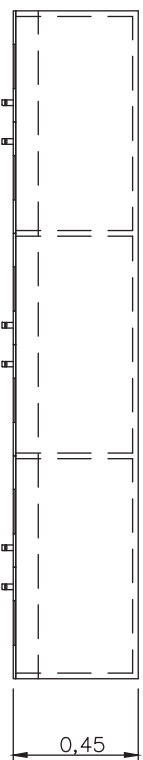
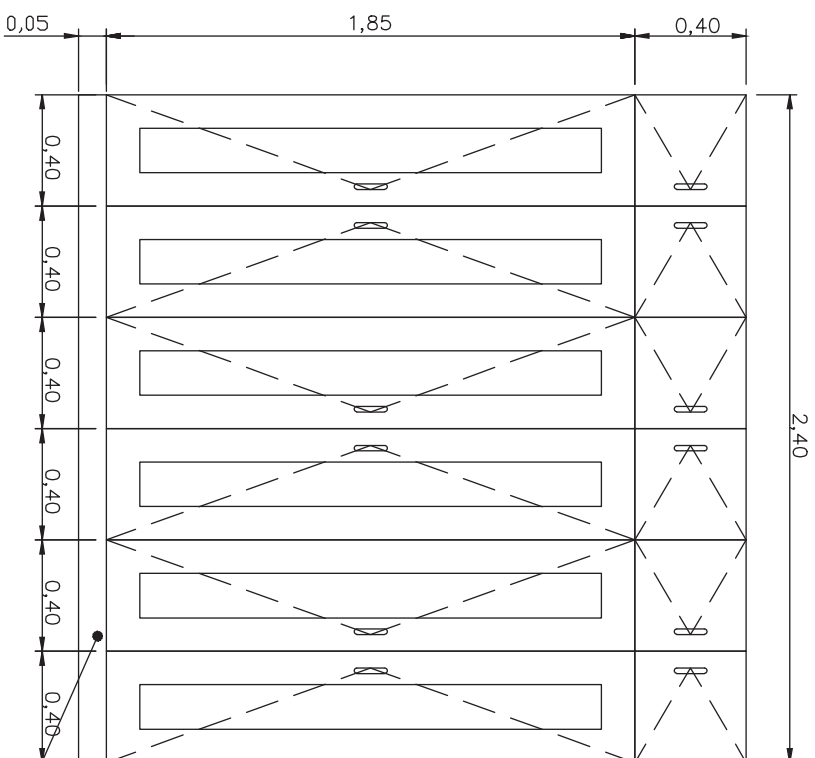

Torta de nivelación

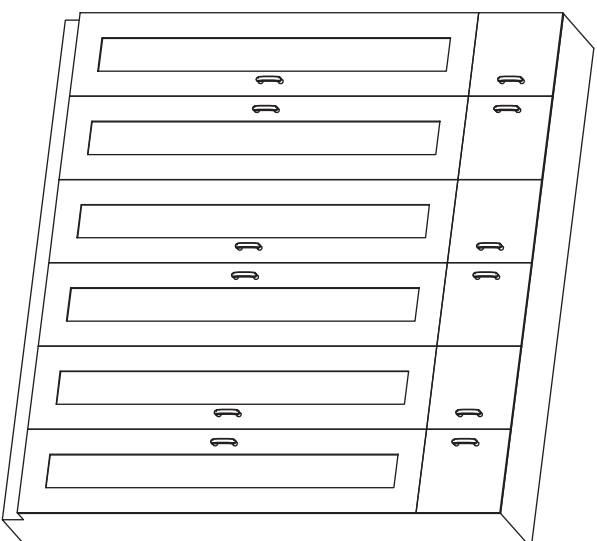
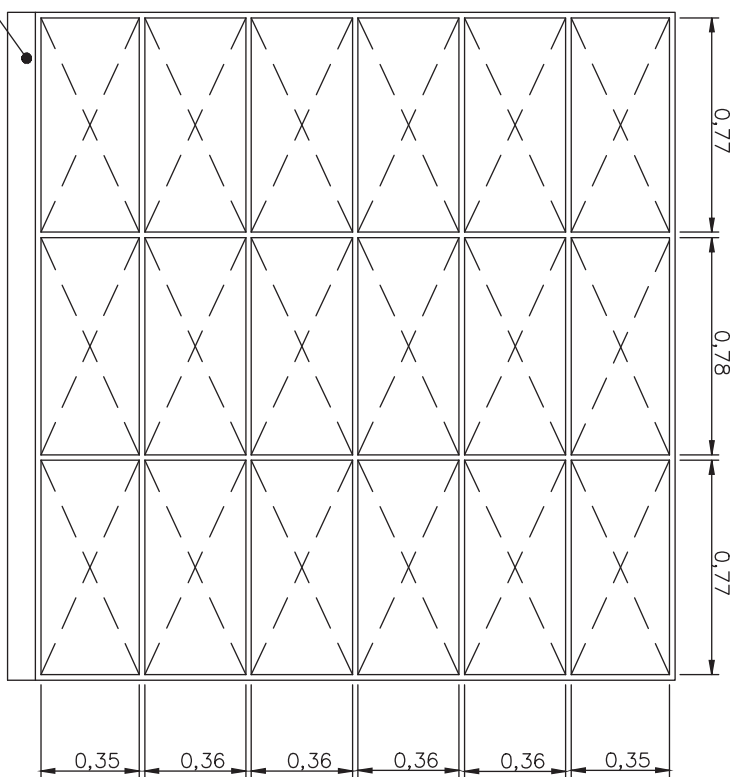

ME 2.51

SOLO ESPECIFICACIÓN TÉCNICA

ME 2.52

SOLO ESPECIFICACIÓN TÉCNICA

ME 2.53

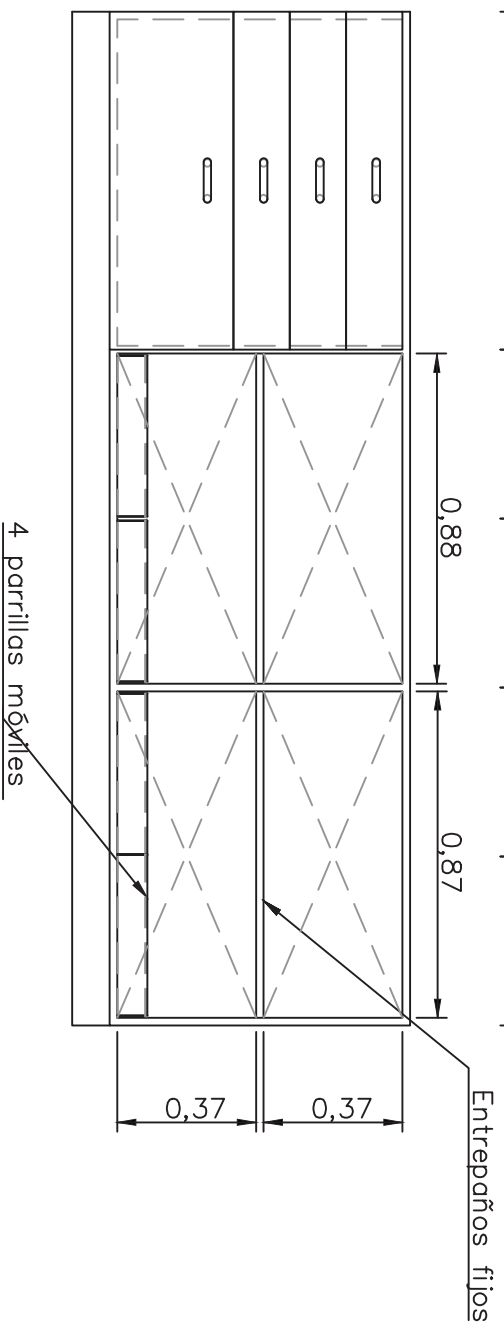
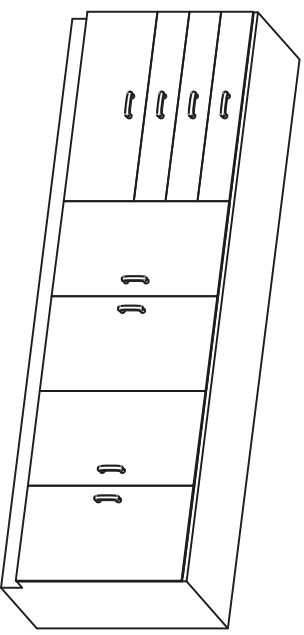
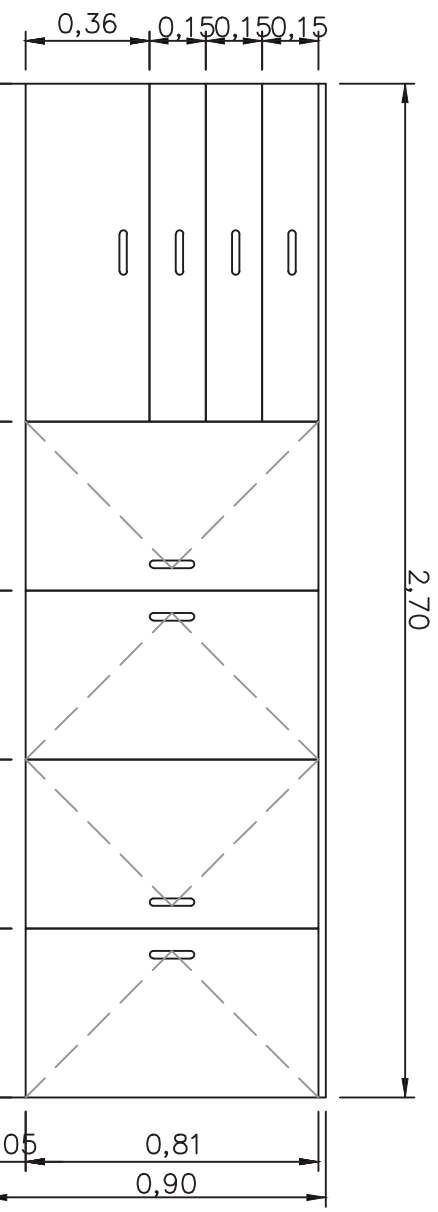
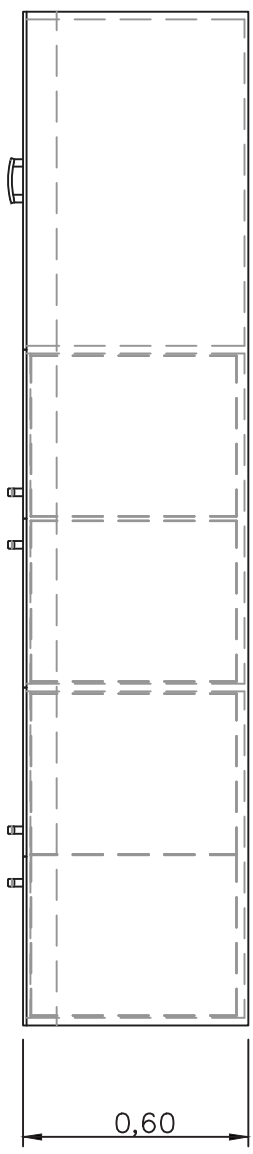

ME 2.54

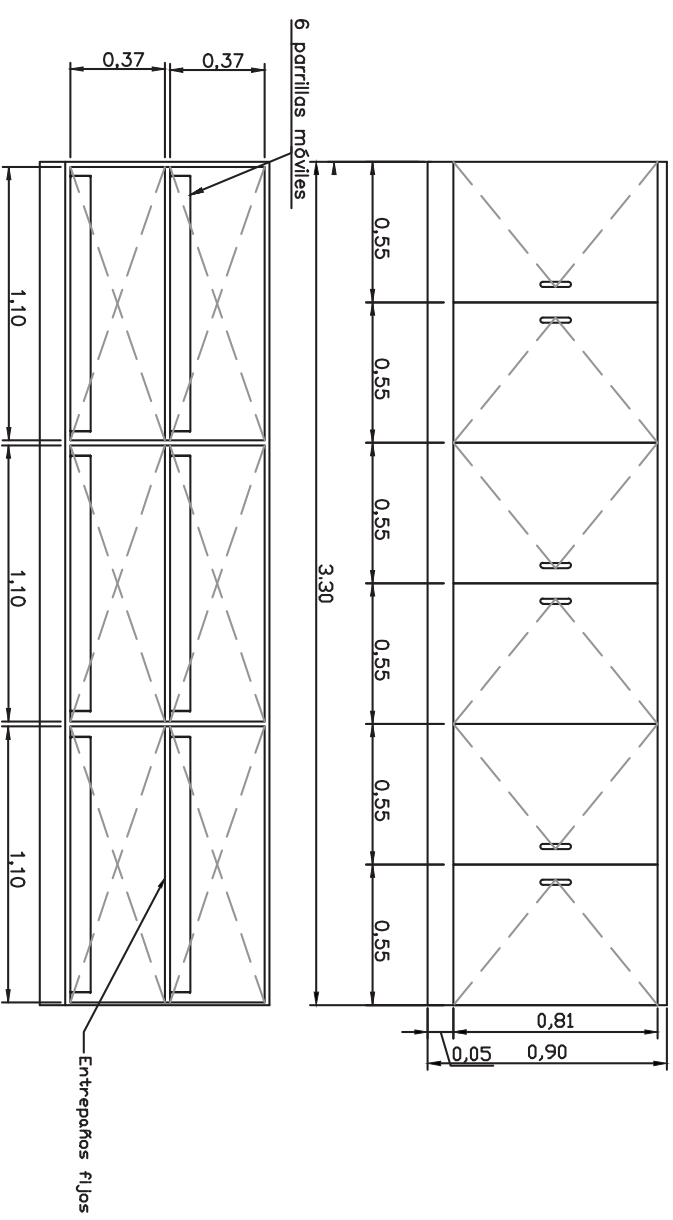
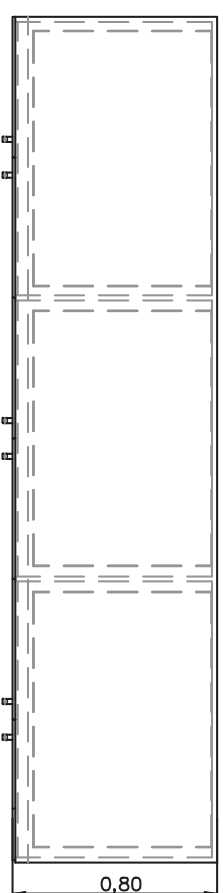
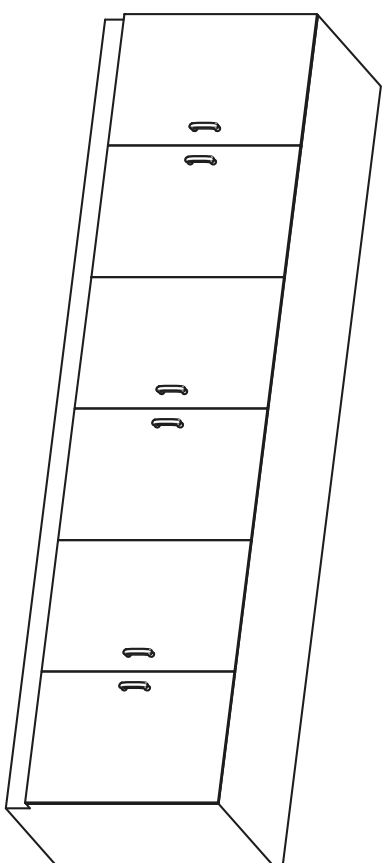

ME 2.55

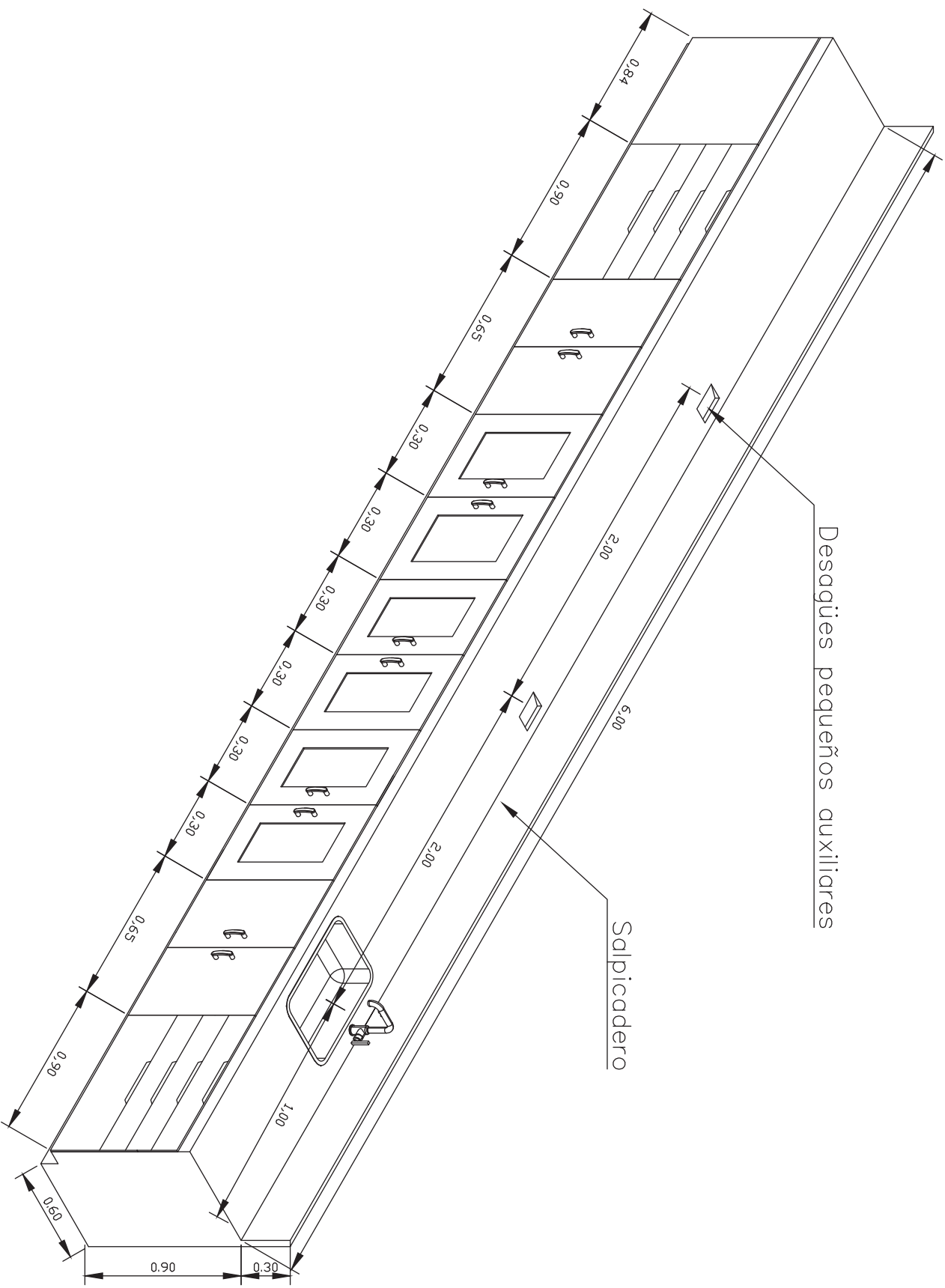

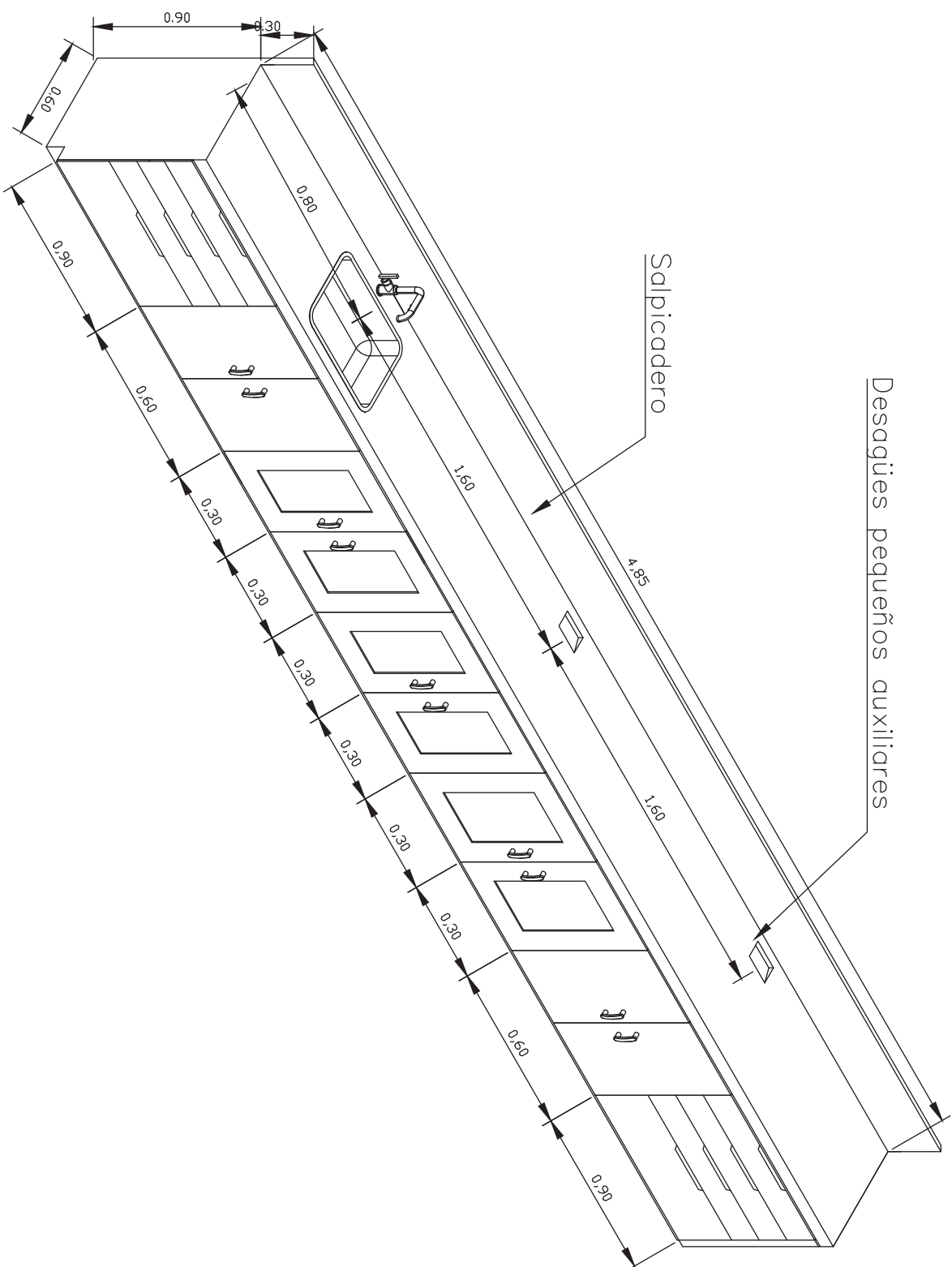

ME 2.57

PLANTA

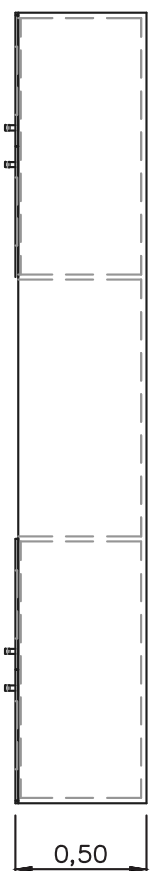

MUEBLE CERRADO

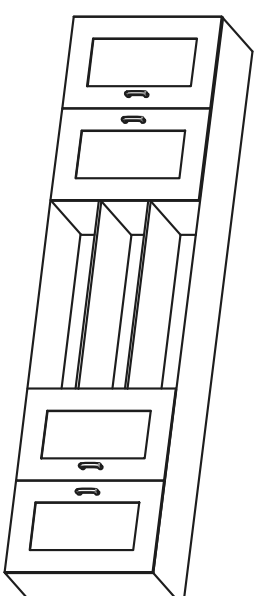
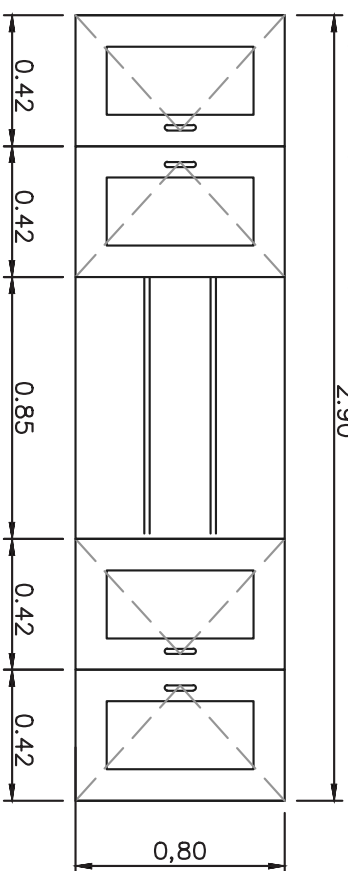

0.85

Entrepisos móviles

MUEBLE ABIERTO

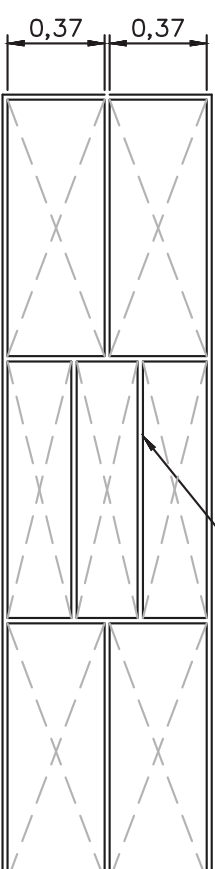

ME 2.58

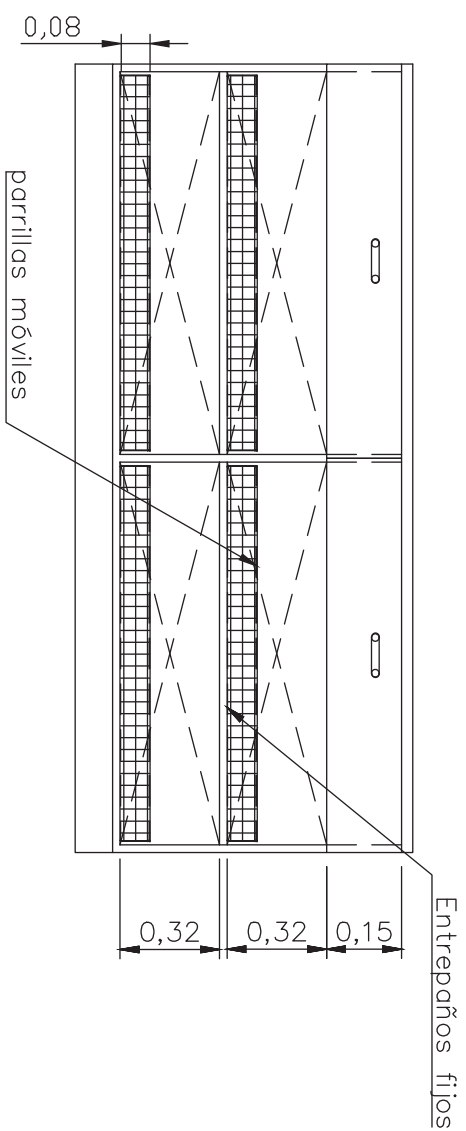
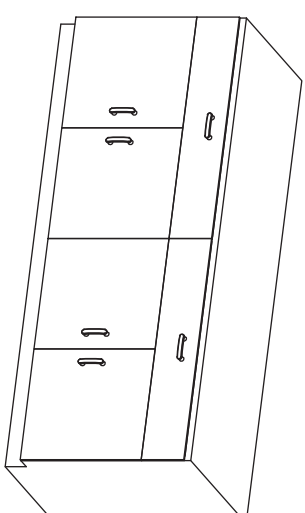
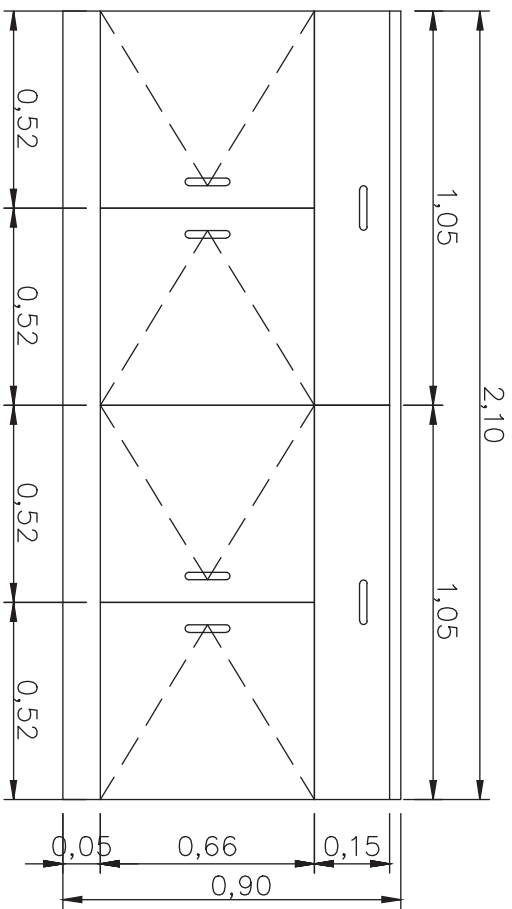
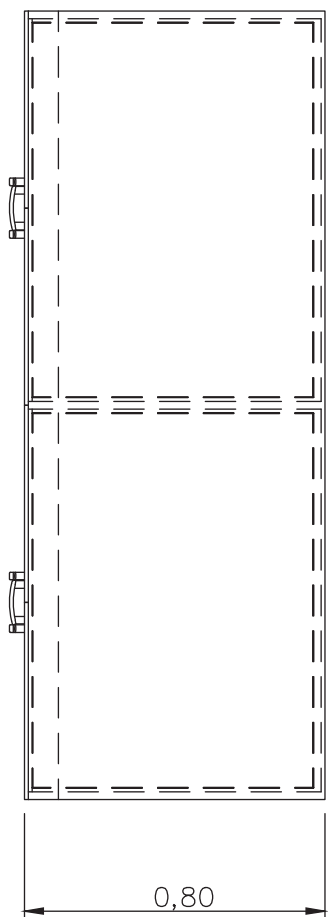

ME 2.59

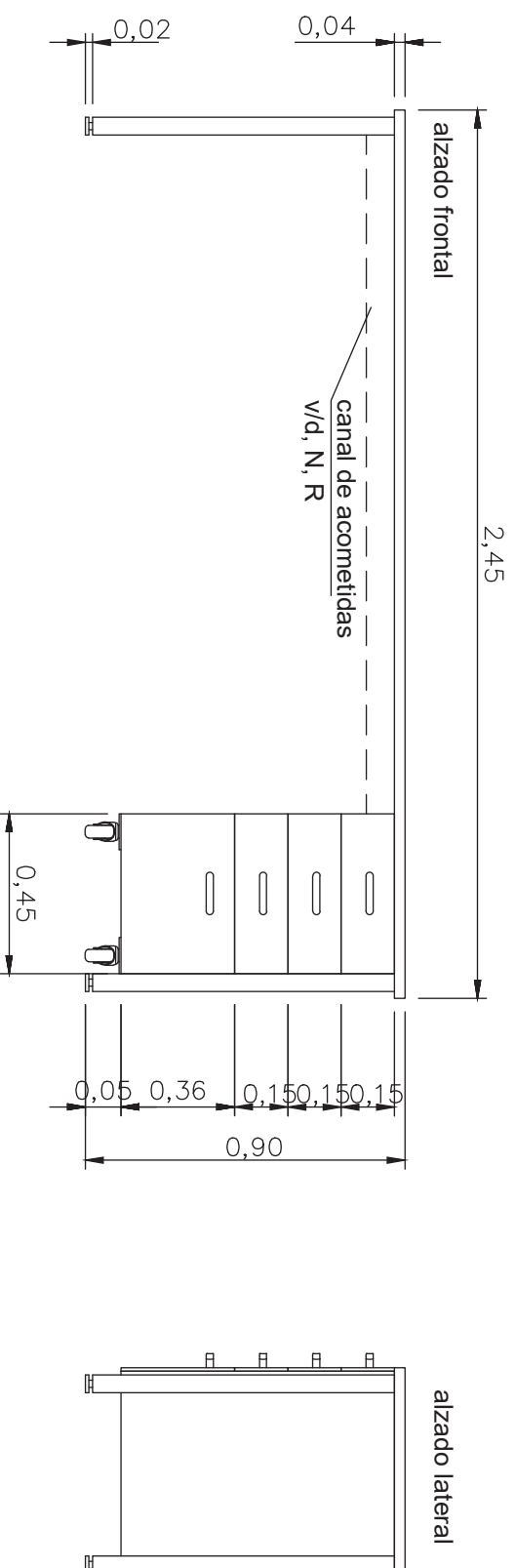
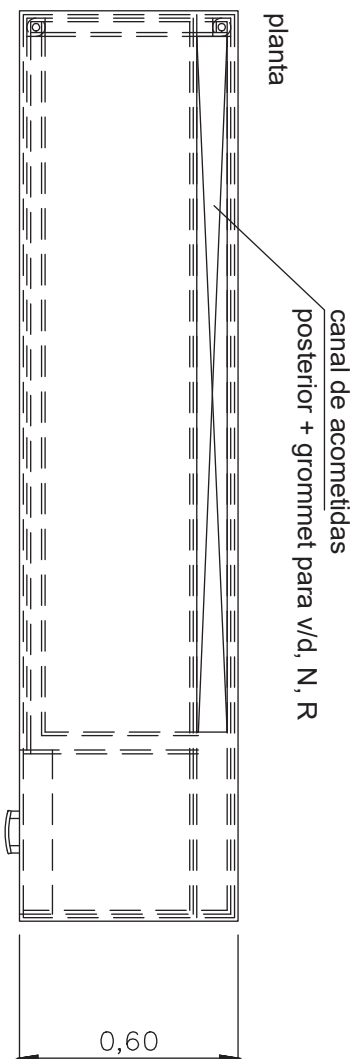
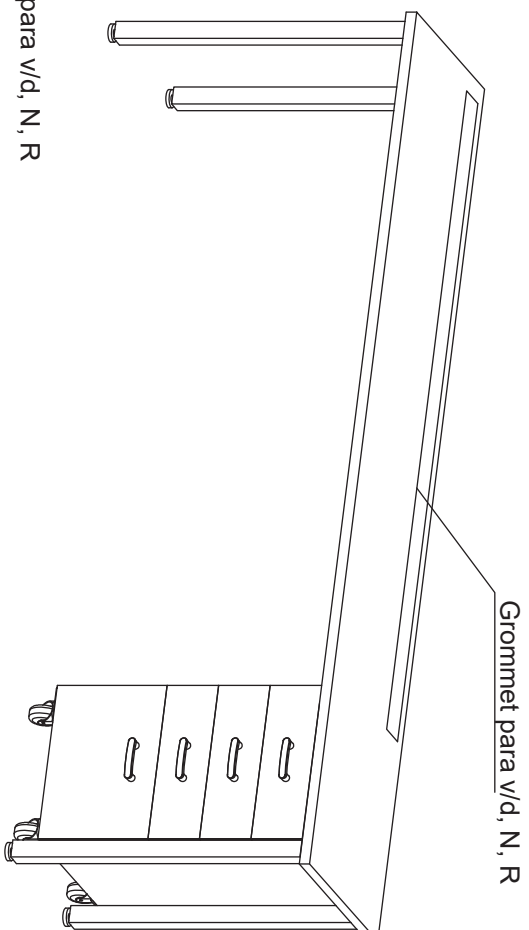

ME 2.60

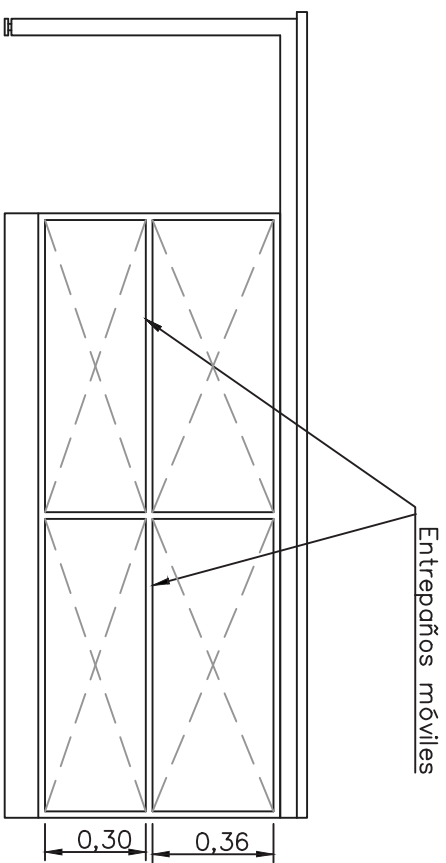
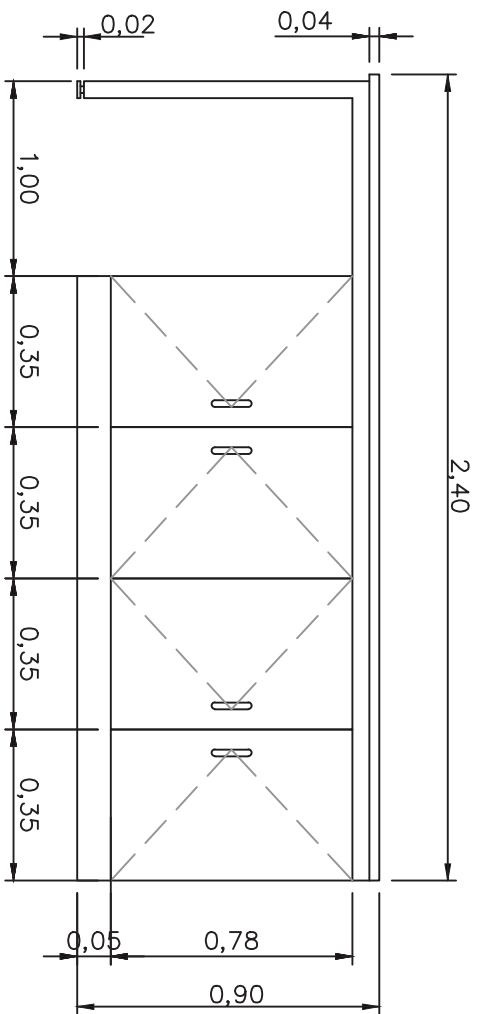
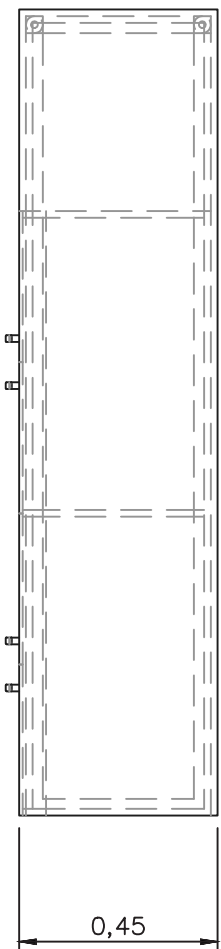
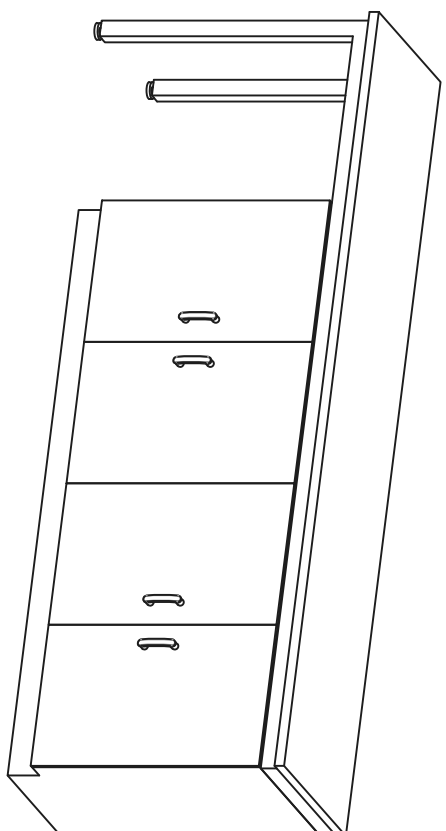

ME 2.61

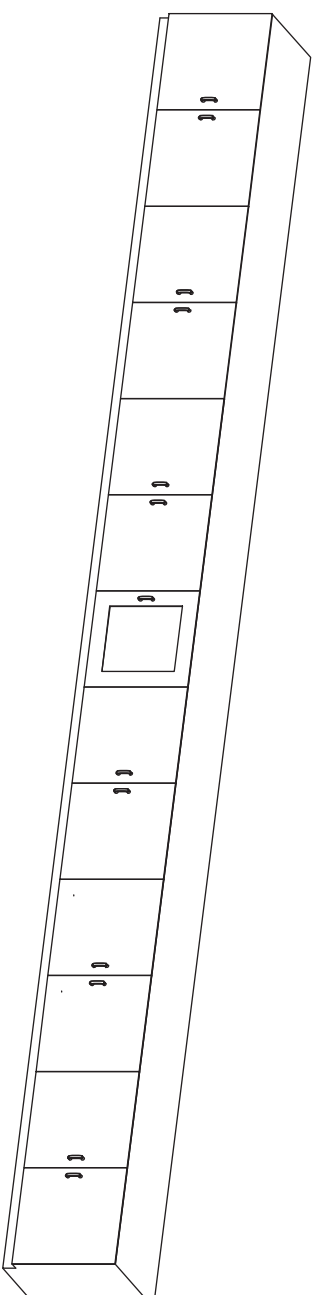

Planta

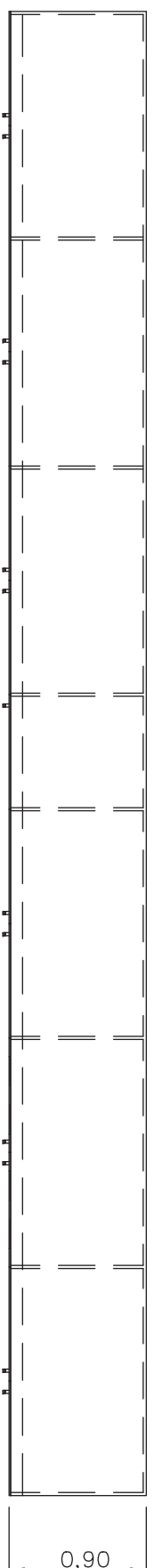

6,70

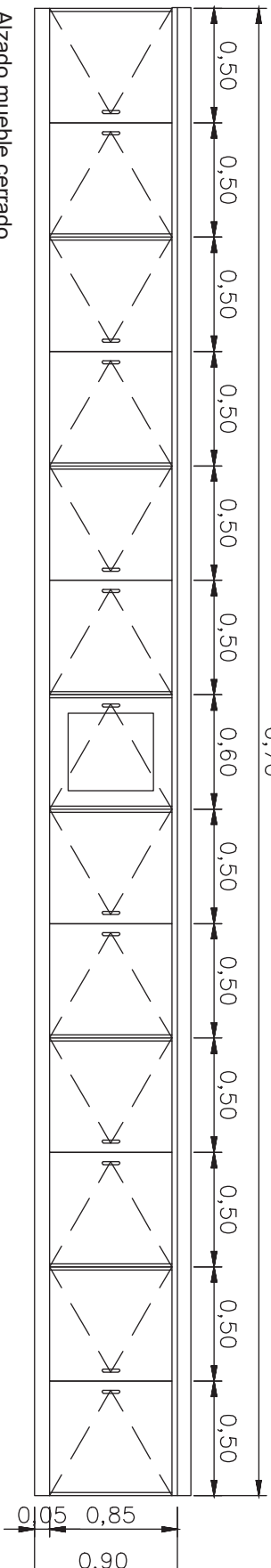

Alzado mueble cerrado

Entrepauños fijos

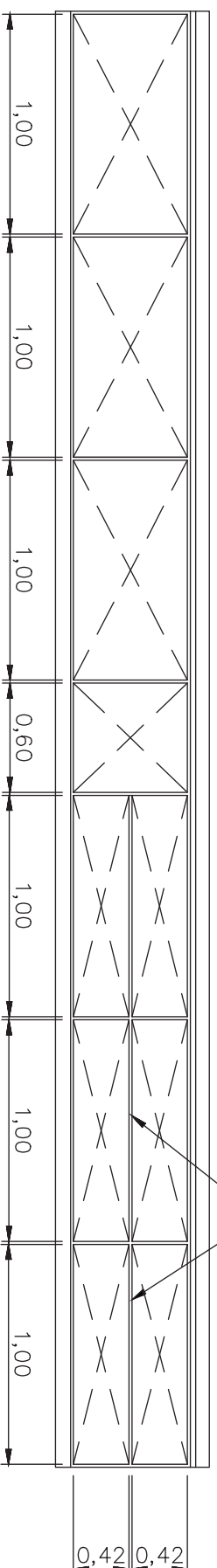

Alzado mueble abierto

