



UNIVERSIDAD DISTRITAL FRANCISCO JOSÉ DE CALDAS

DOCUMENTO DE COTIZACIÓN MOBILIARIO PROYECTO AMPLIACIÓN SEDE TECNOLÓGICA.

LOTE 1

Mobiliario convencional

NOTA:

Se requiere hacer una visita técnica a obra previa al inicio de la fabricación del mobiliario para corroborar medidas en sitio, la ubicación del mobiliario y las distintas acometidas en el caso que lo requieran

MC 1.1

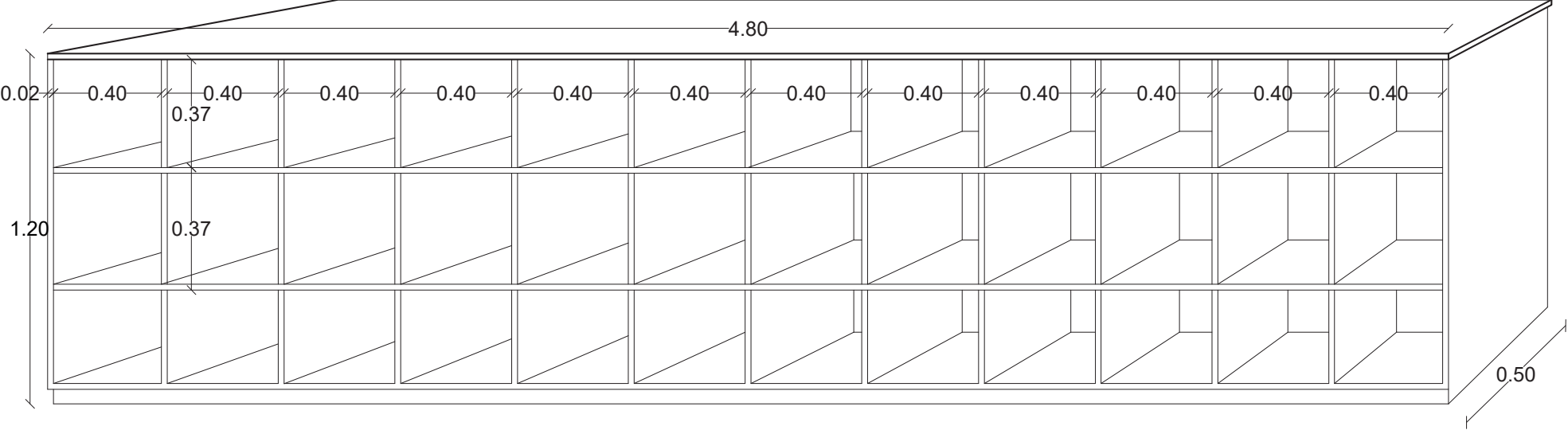

MC 1.2

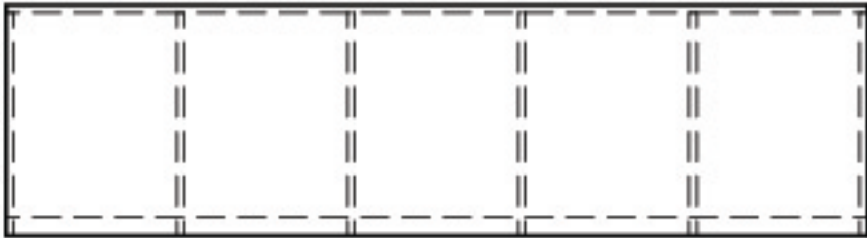

PLANTA

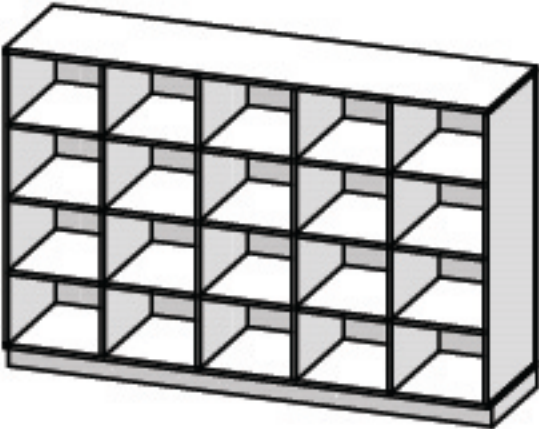

PERSPECTIVA

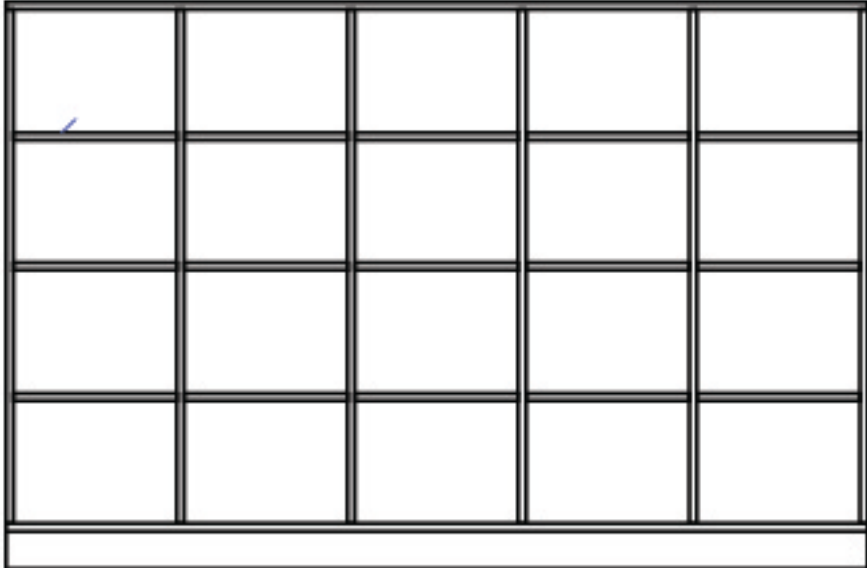

ALZADO

MC 1.3

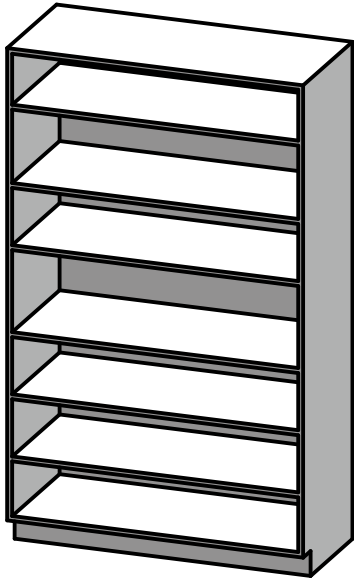
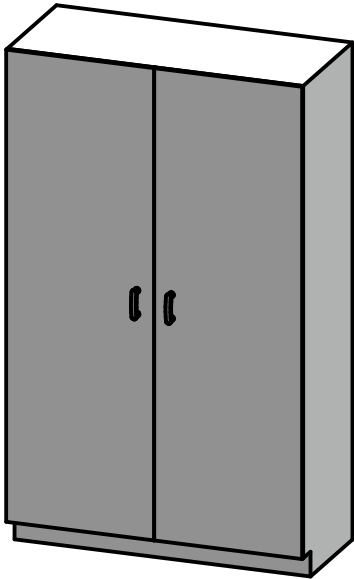
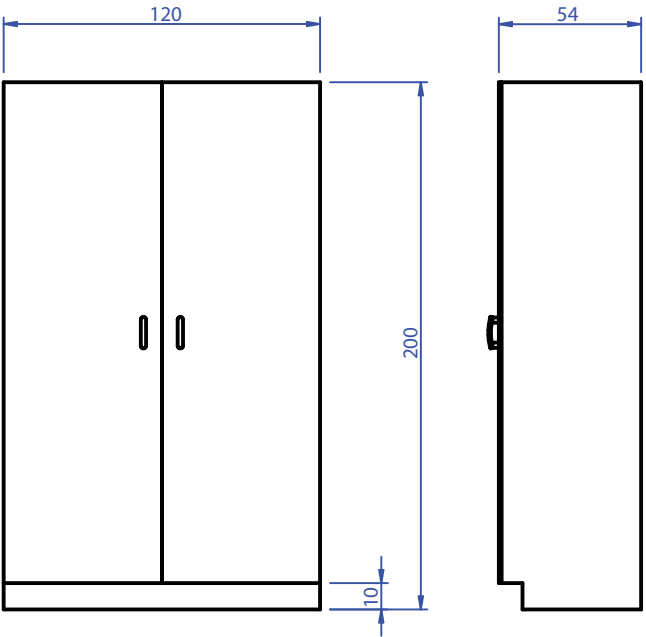

MC 1.4

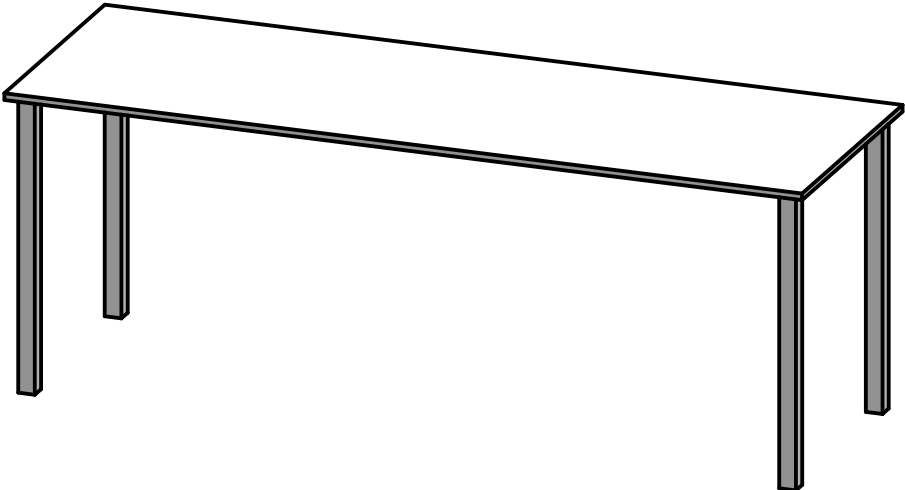
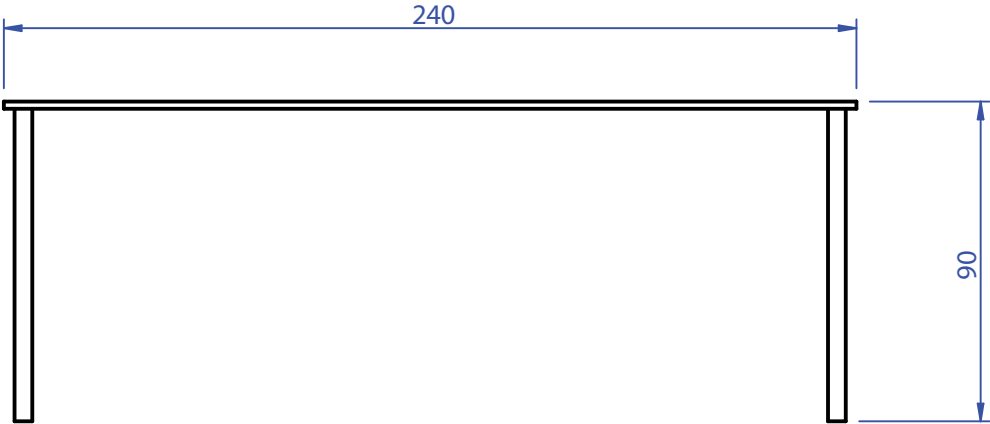

MC 1.5

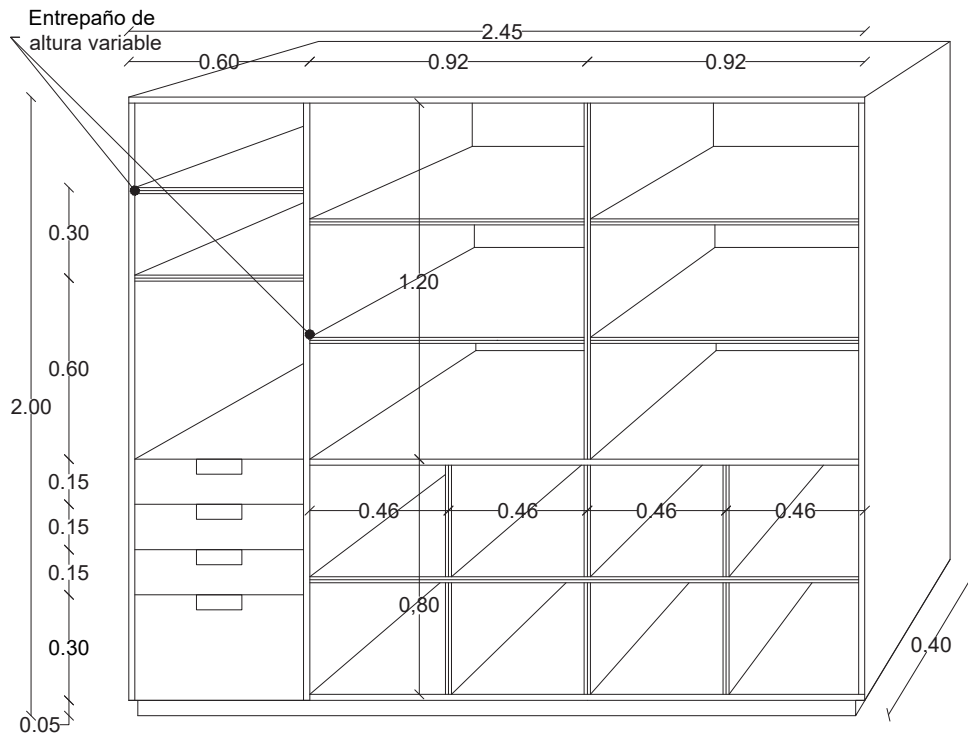

Mueble abierto

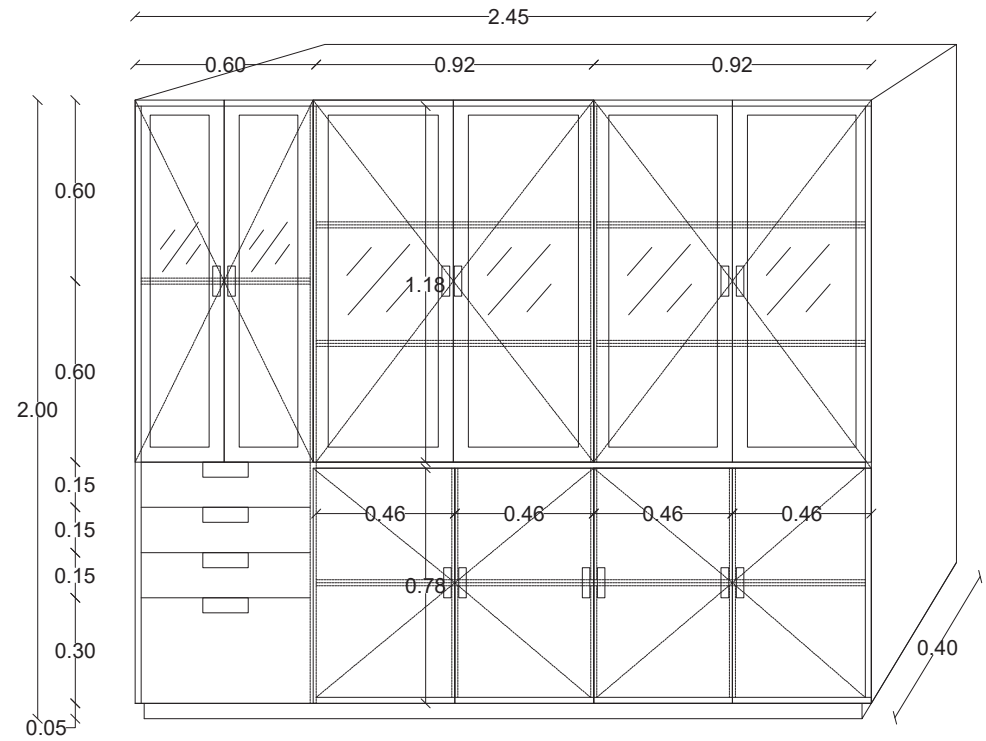

Mueble Cerrado

MC 1.6

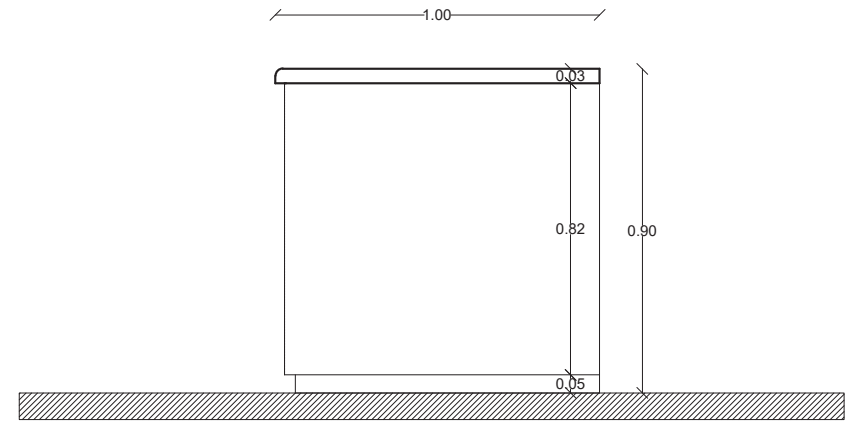
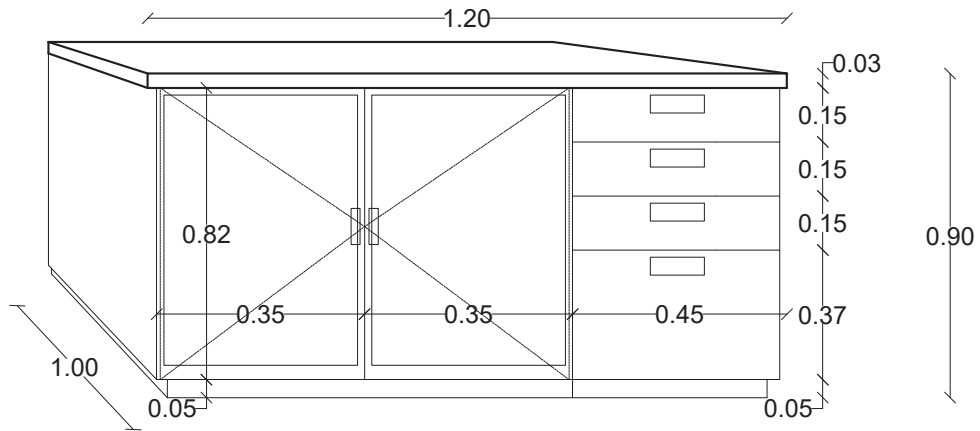

Mueble Exterior

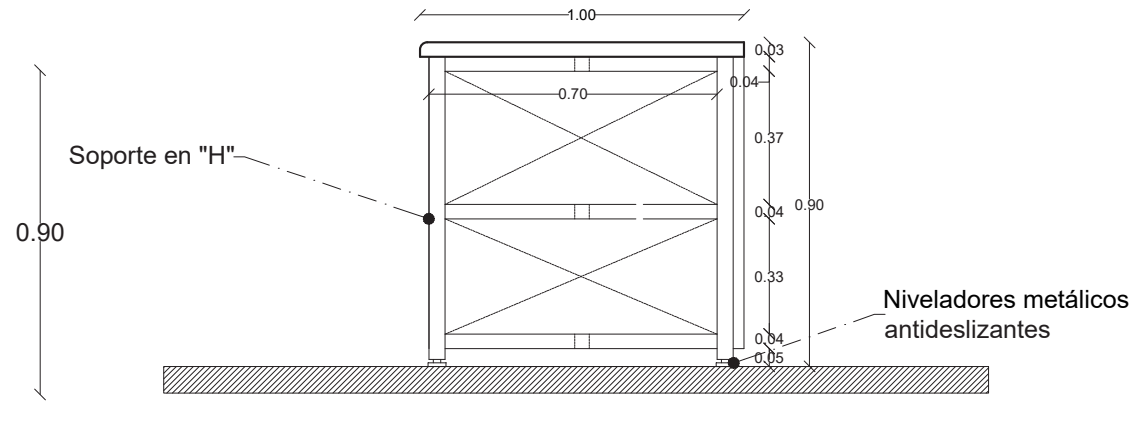
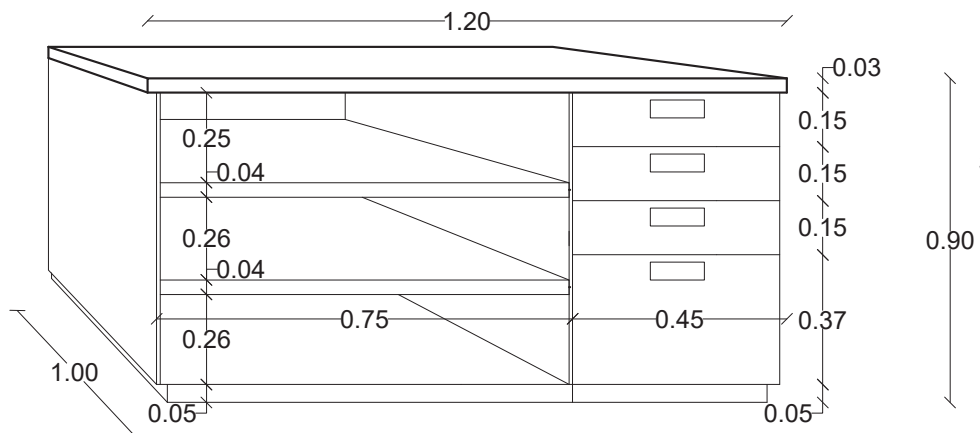

Mueble interior

MC 1.7

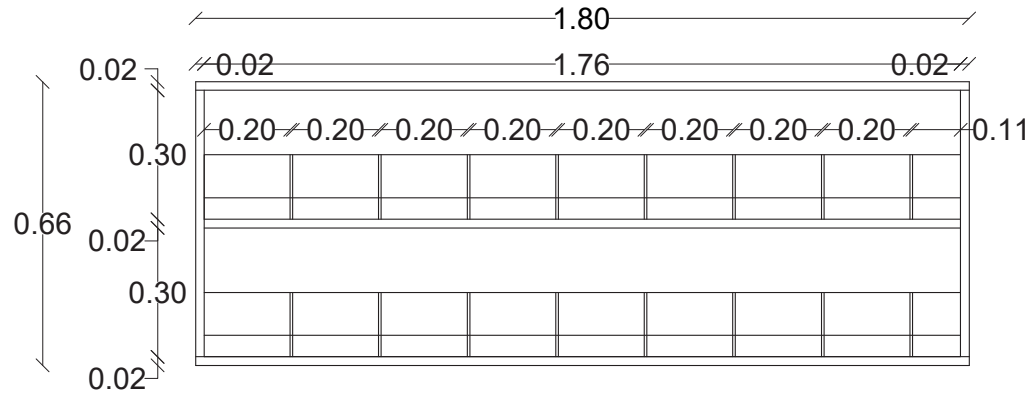

Detalle soporte de Tamiz

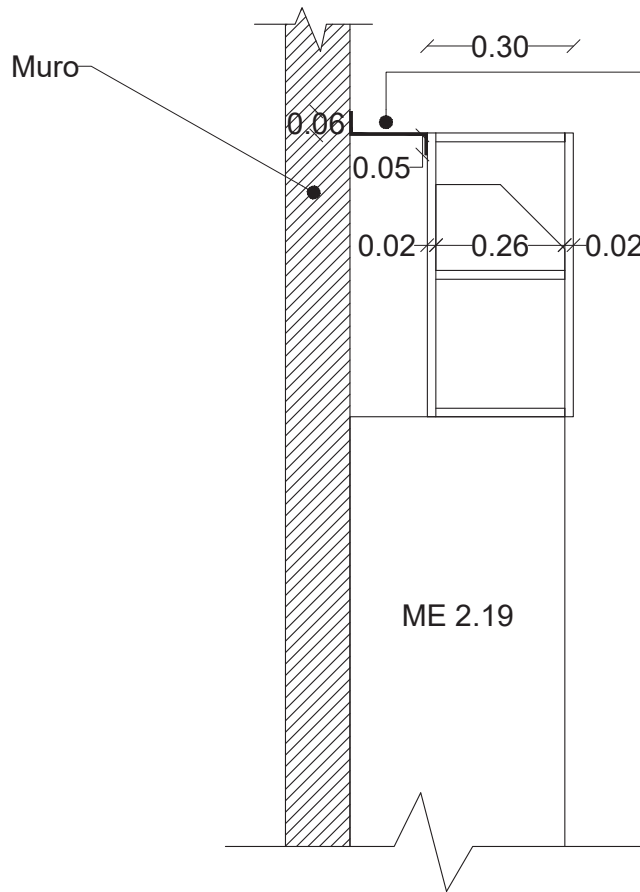
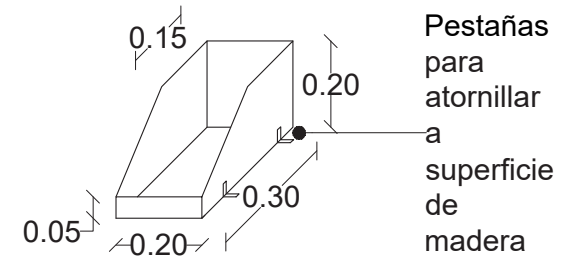

Platina que ancla el mueble a muro

Planta

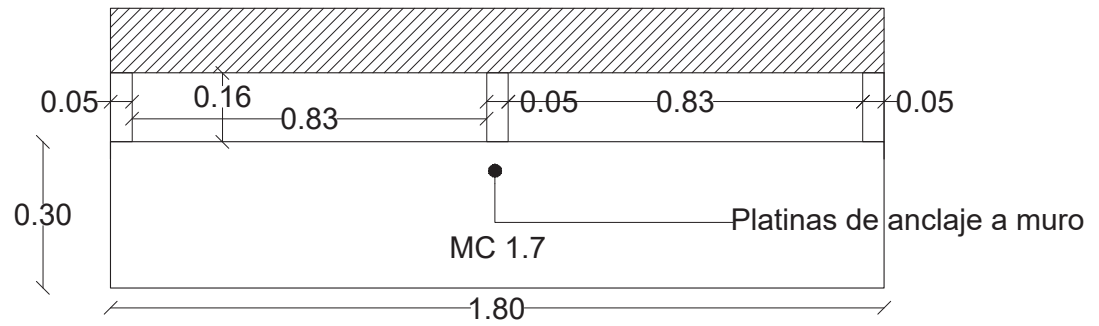

MC 1.7

Platinas de anclaje a muro

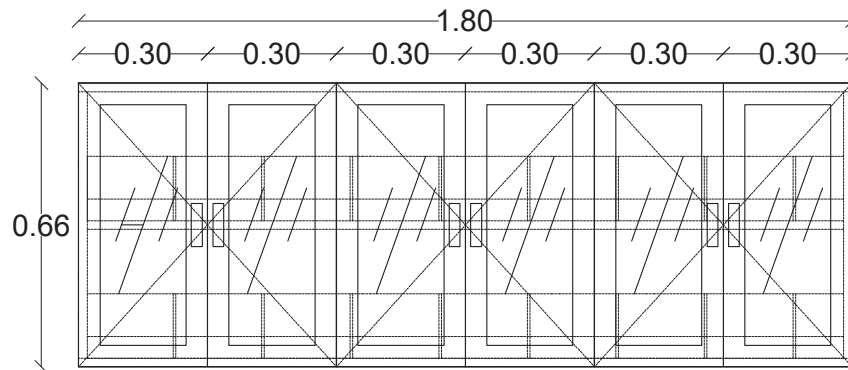

Detalle Puerta

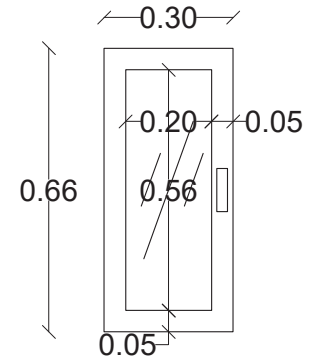

MC 1.8

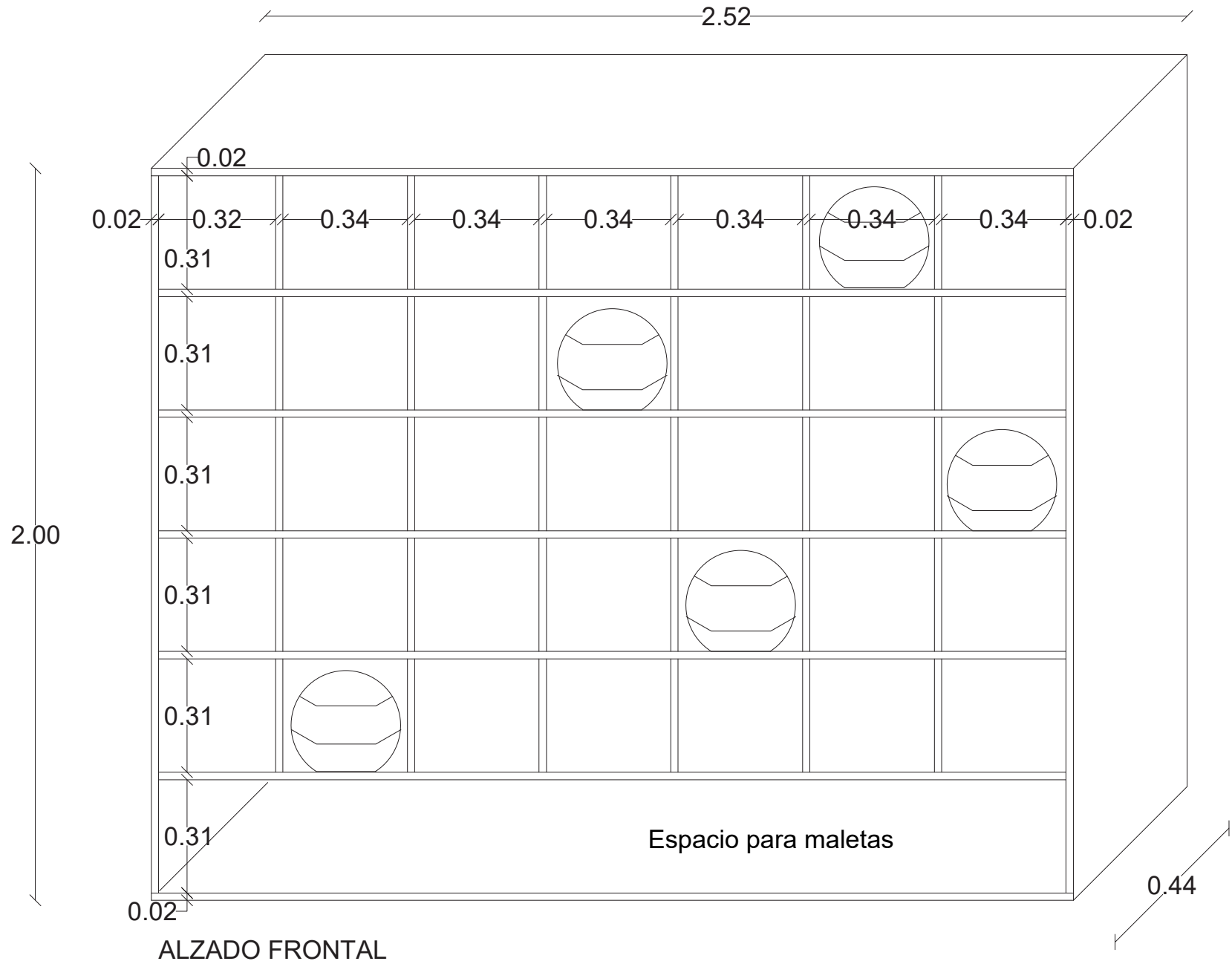

MC 1.9

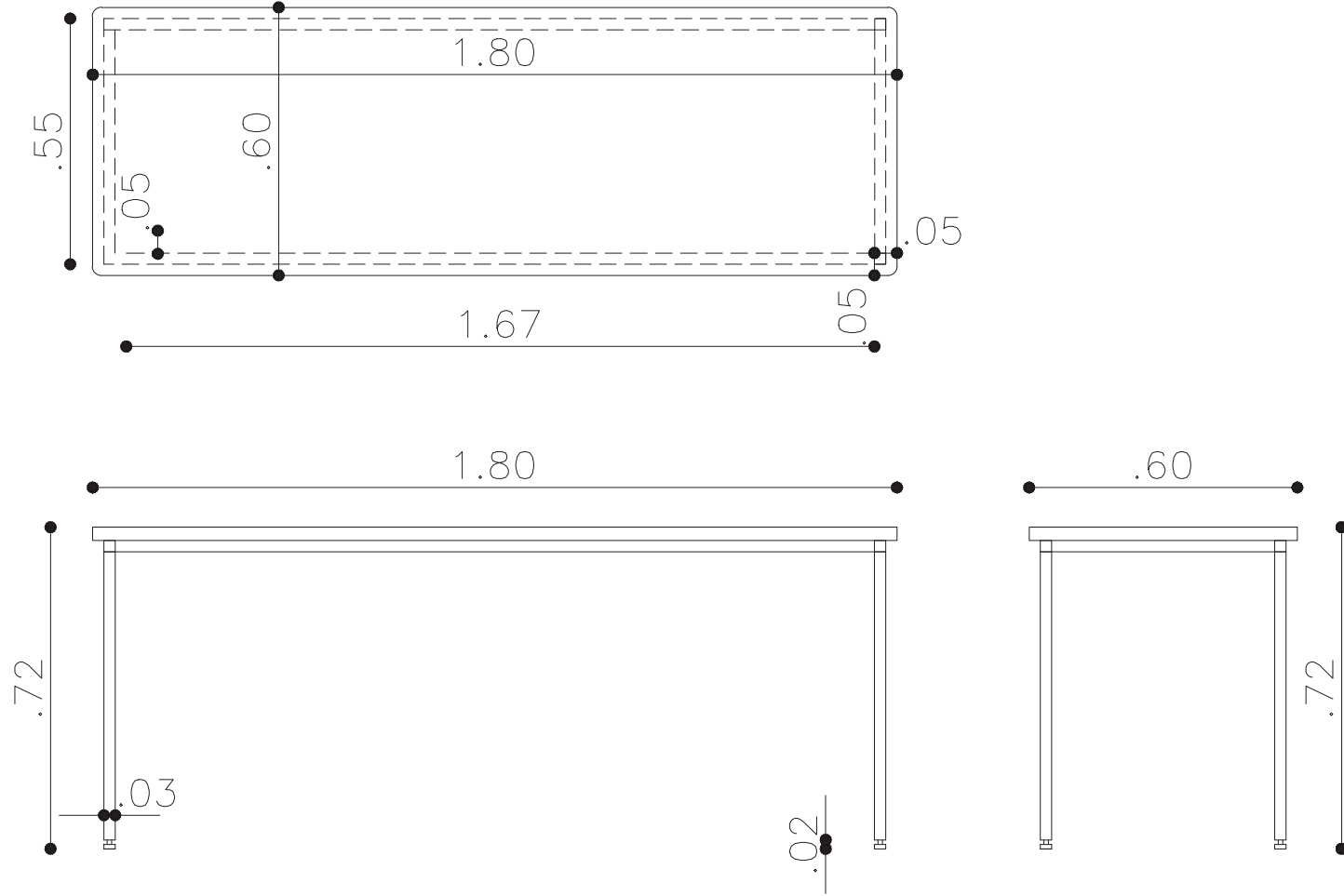

MC 1.10

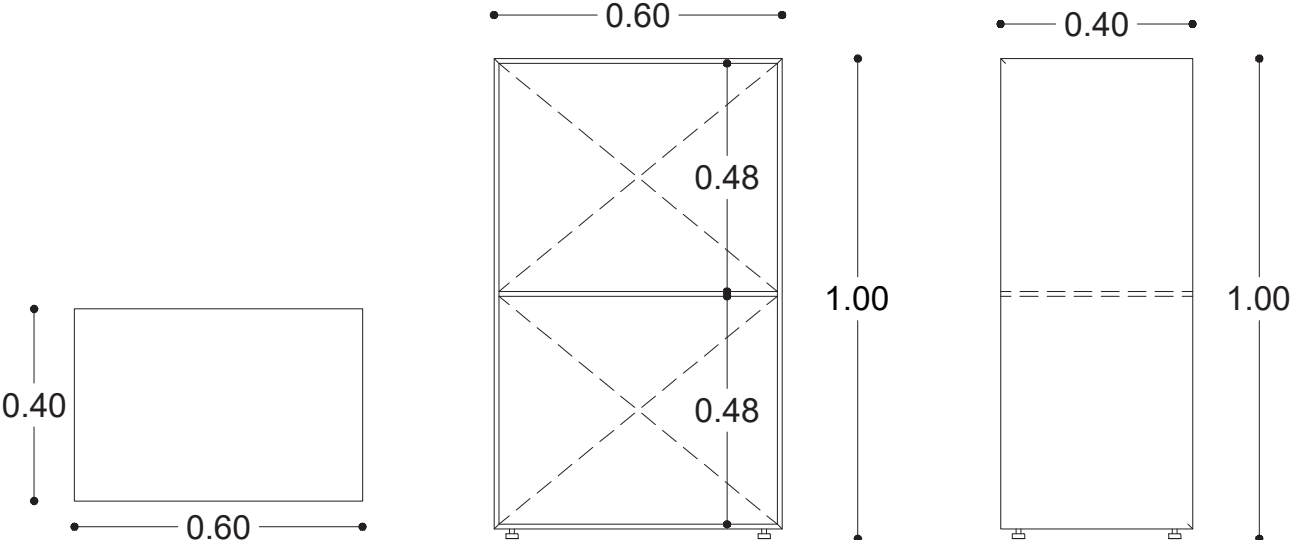

MC 1.11

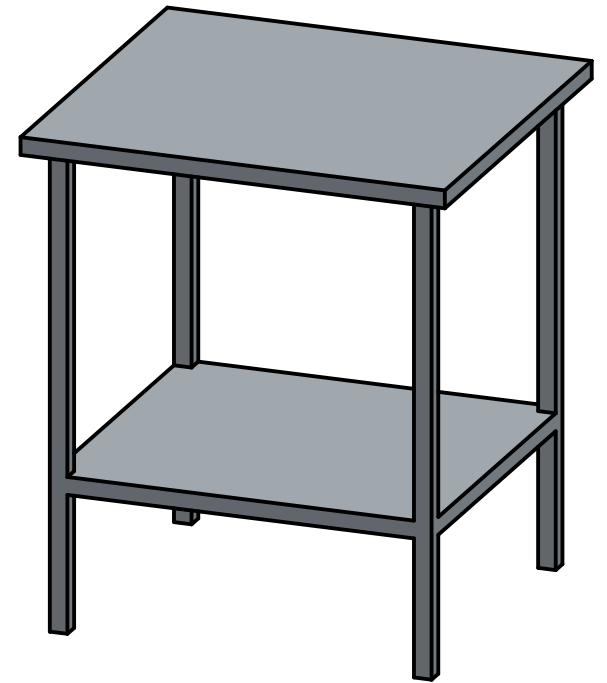
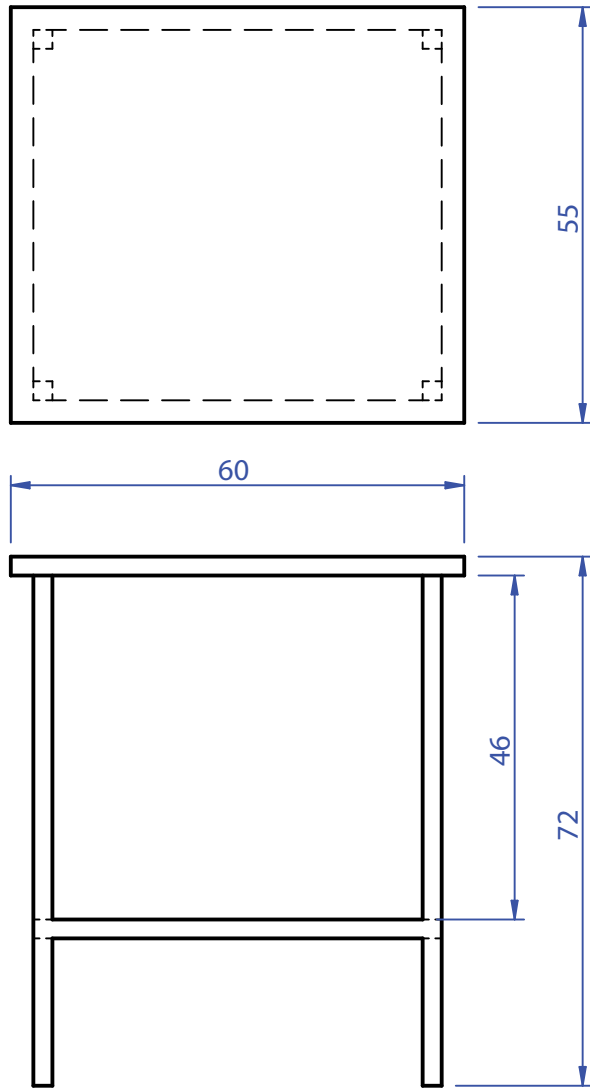

MC 1.12

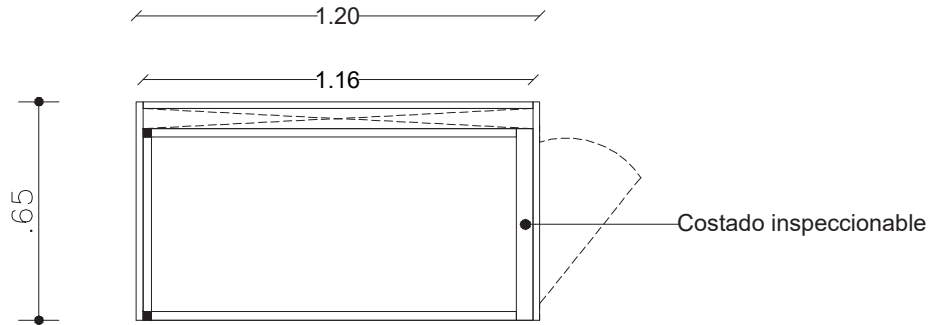

PLANTA

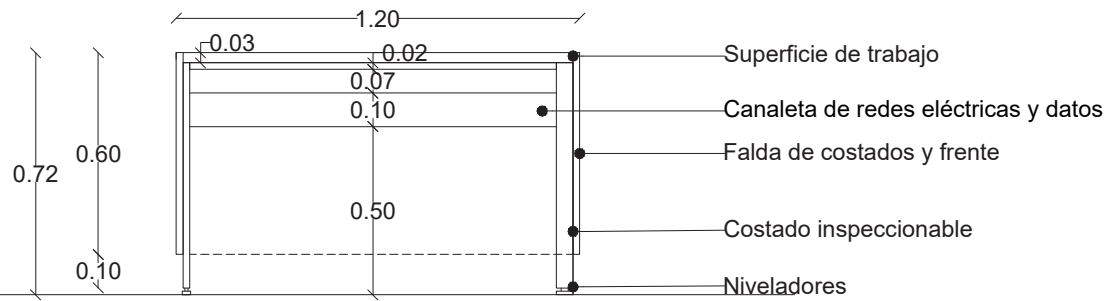

ALZADO FRONTAL

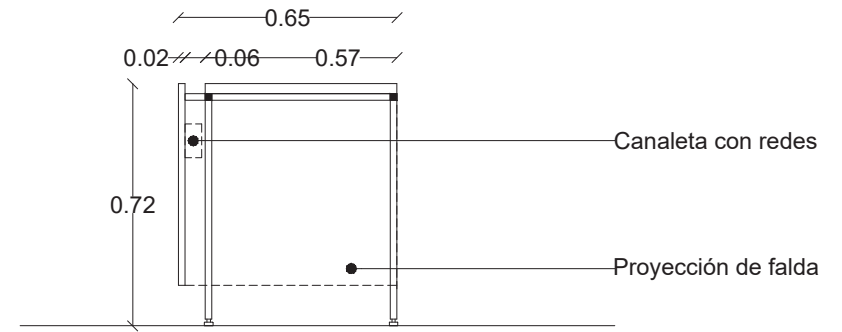

ALZADO LATERAL

MC 1.13

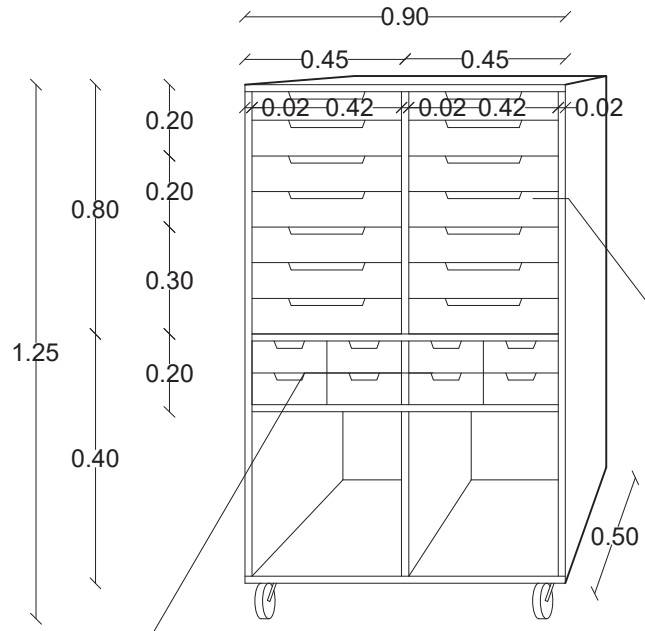

Mueble abierto

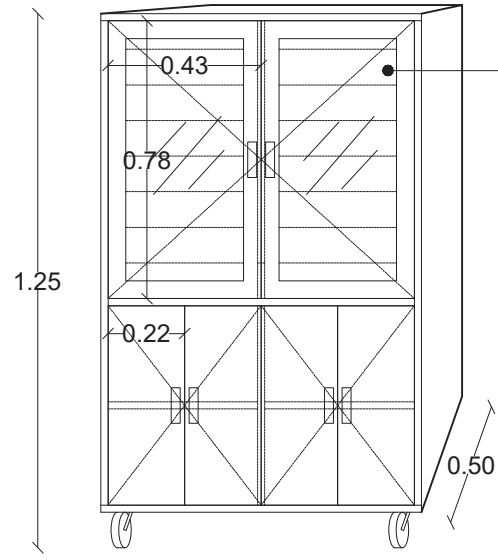

Mueble Cerrado

Paños en vidrio

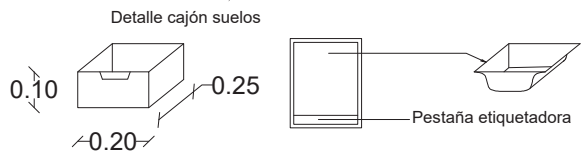

Detalle cajón suelos

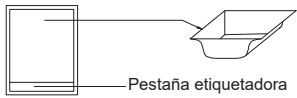

Pestaña etiquetadora

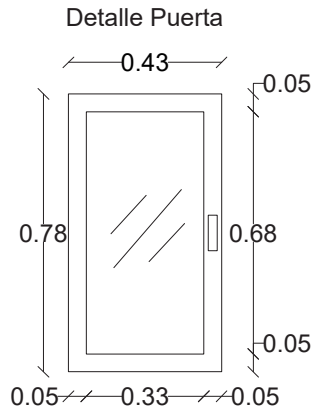

Detalle Puerta

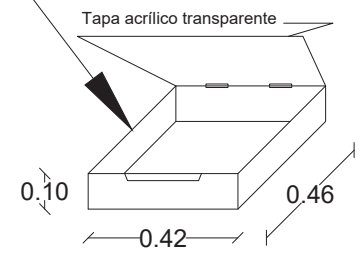

Tapa acrílico transparente

Detalle organizadores cajones grandes

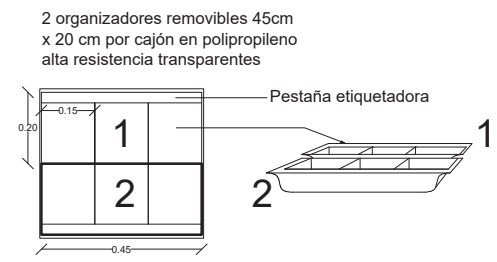

2 organizadores removibles 45cm x 20 cm por cajón en polipropileno alta resistencia transparentes

Pestaña etiquetadora

MC 1.14

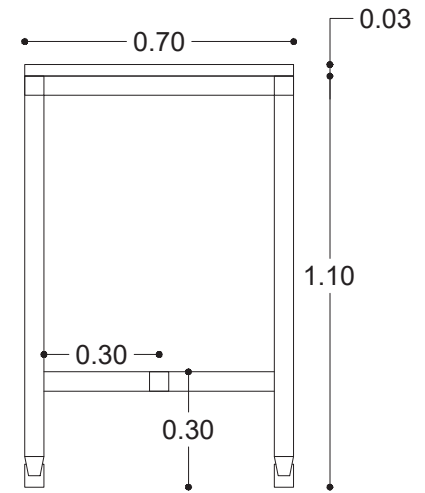
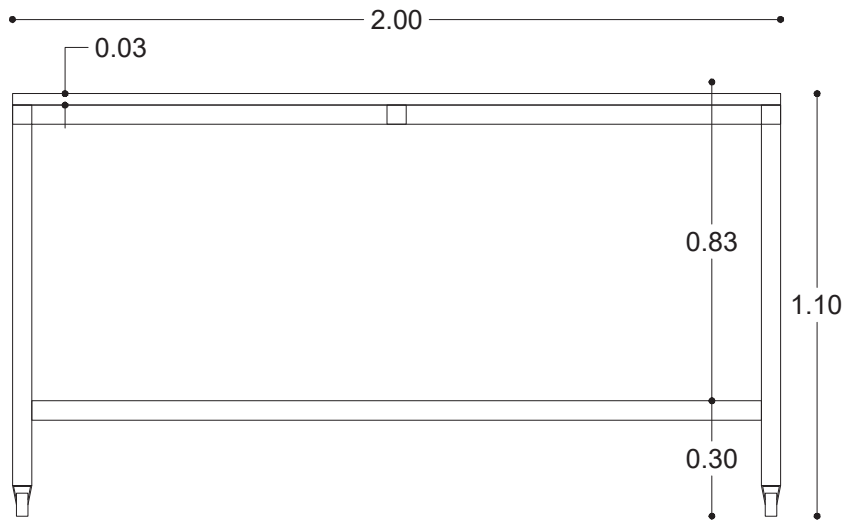
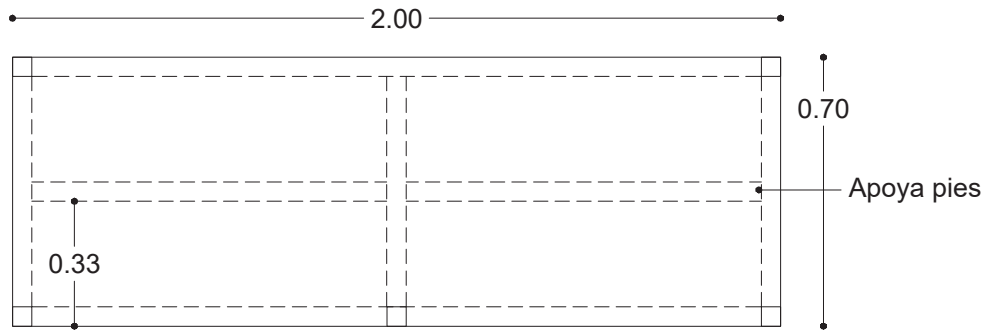

MC 1.15

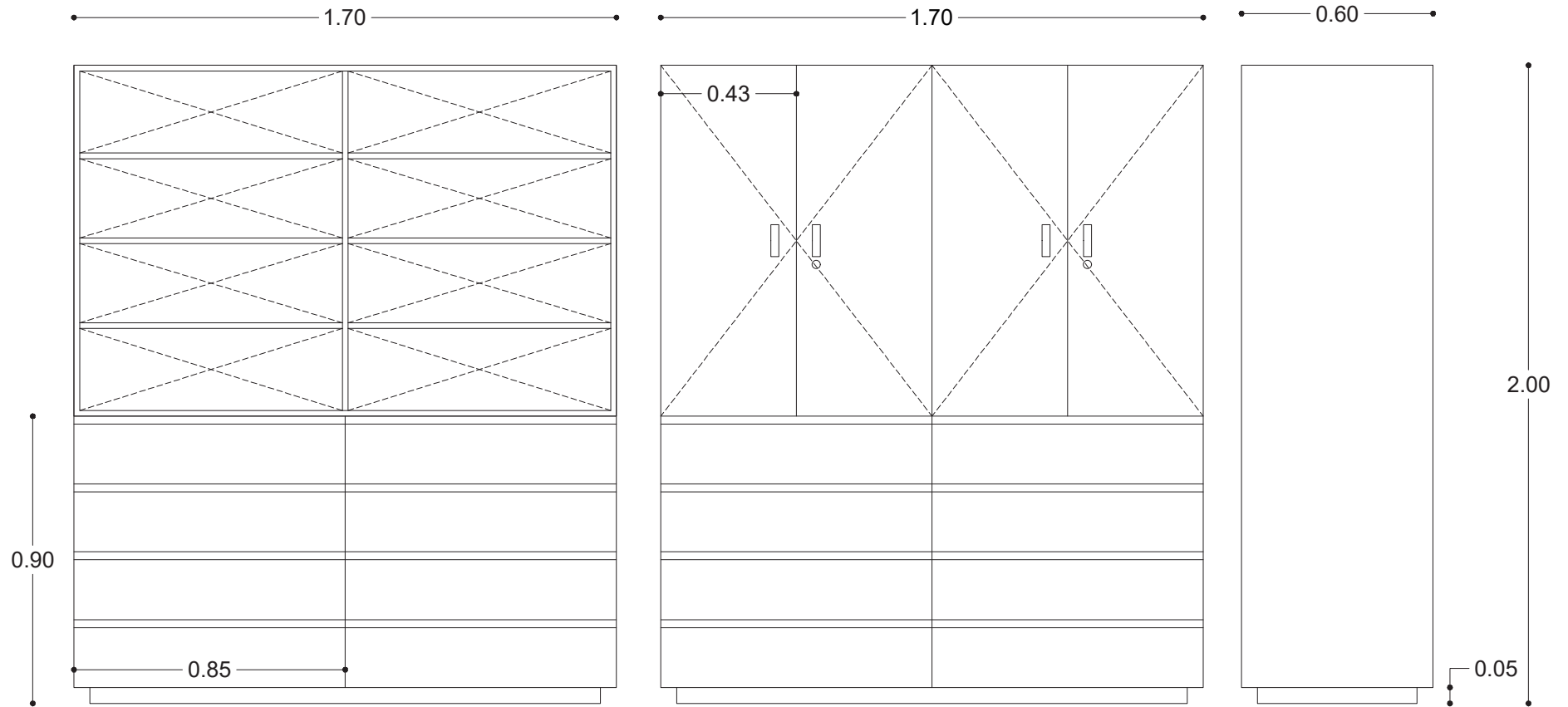

MC 1.16

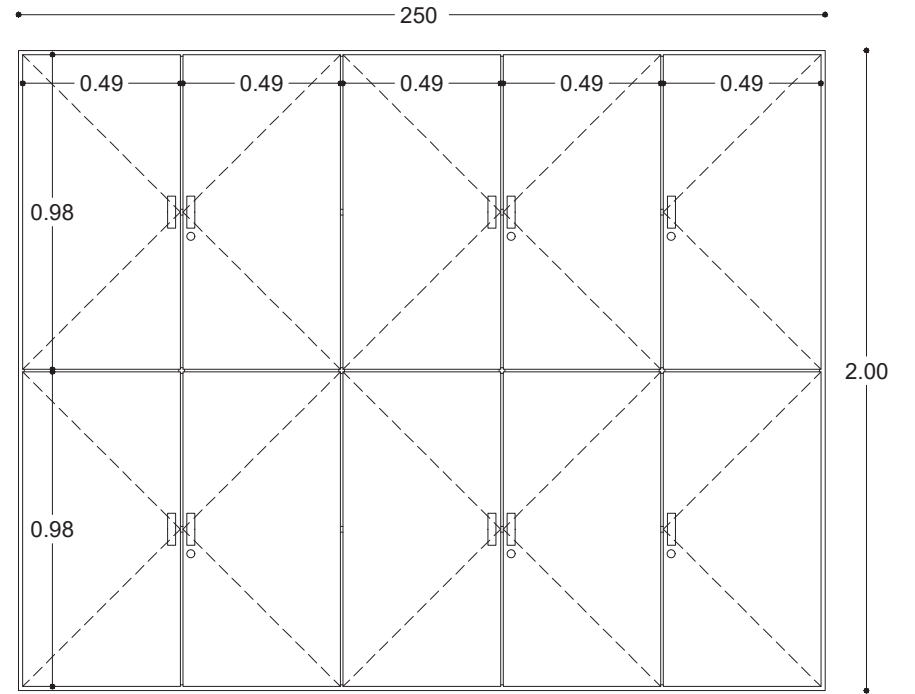
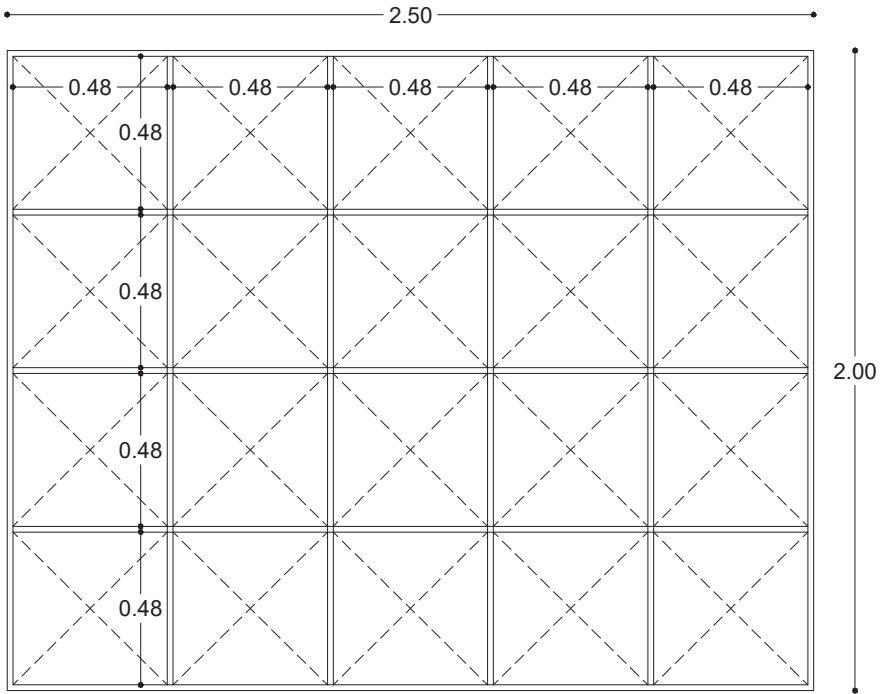
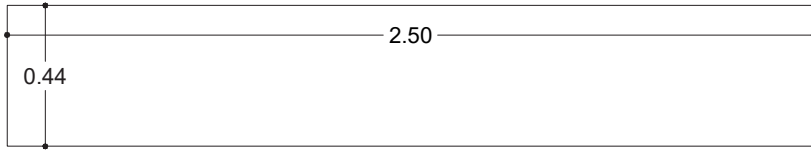

MC 1.17

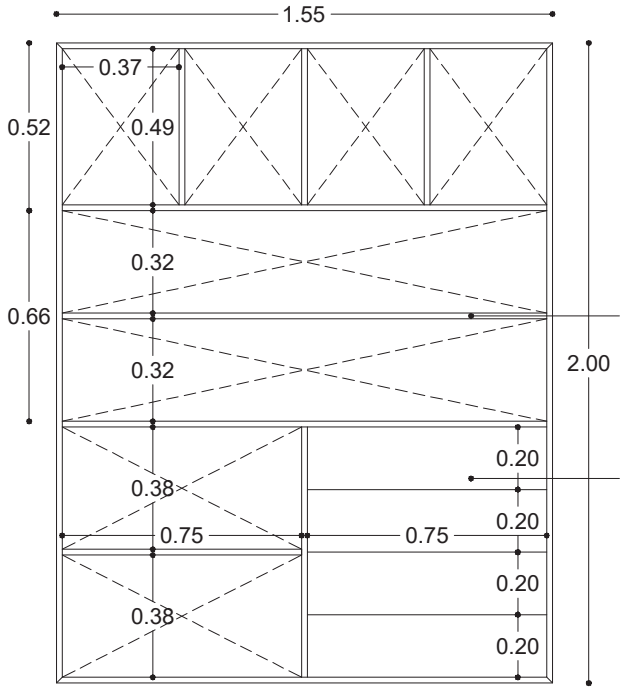
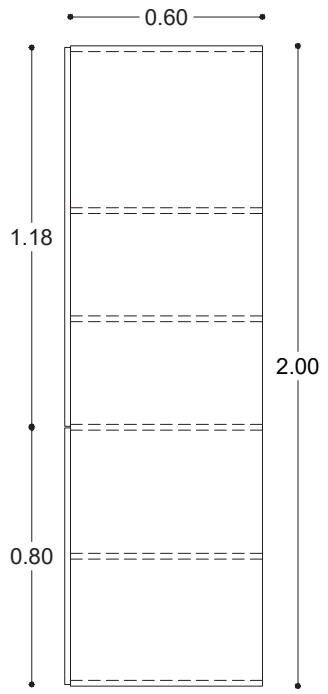

Entrepaño fijo

Cajones

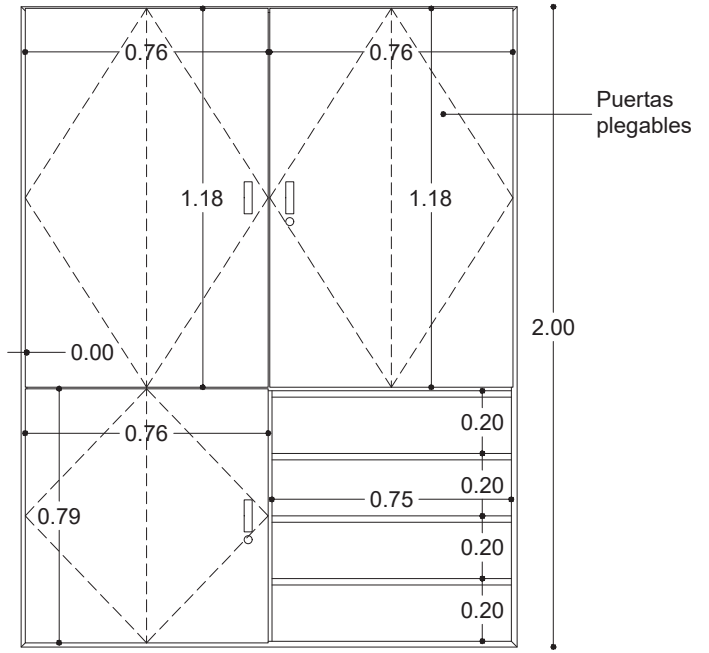

Puertas plegables

MC 1.18

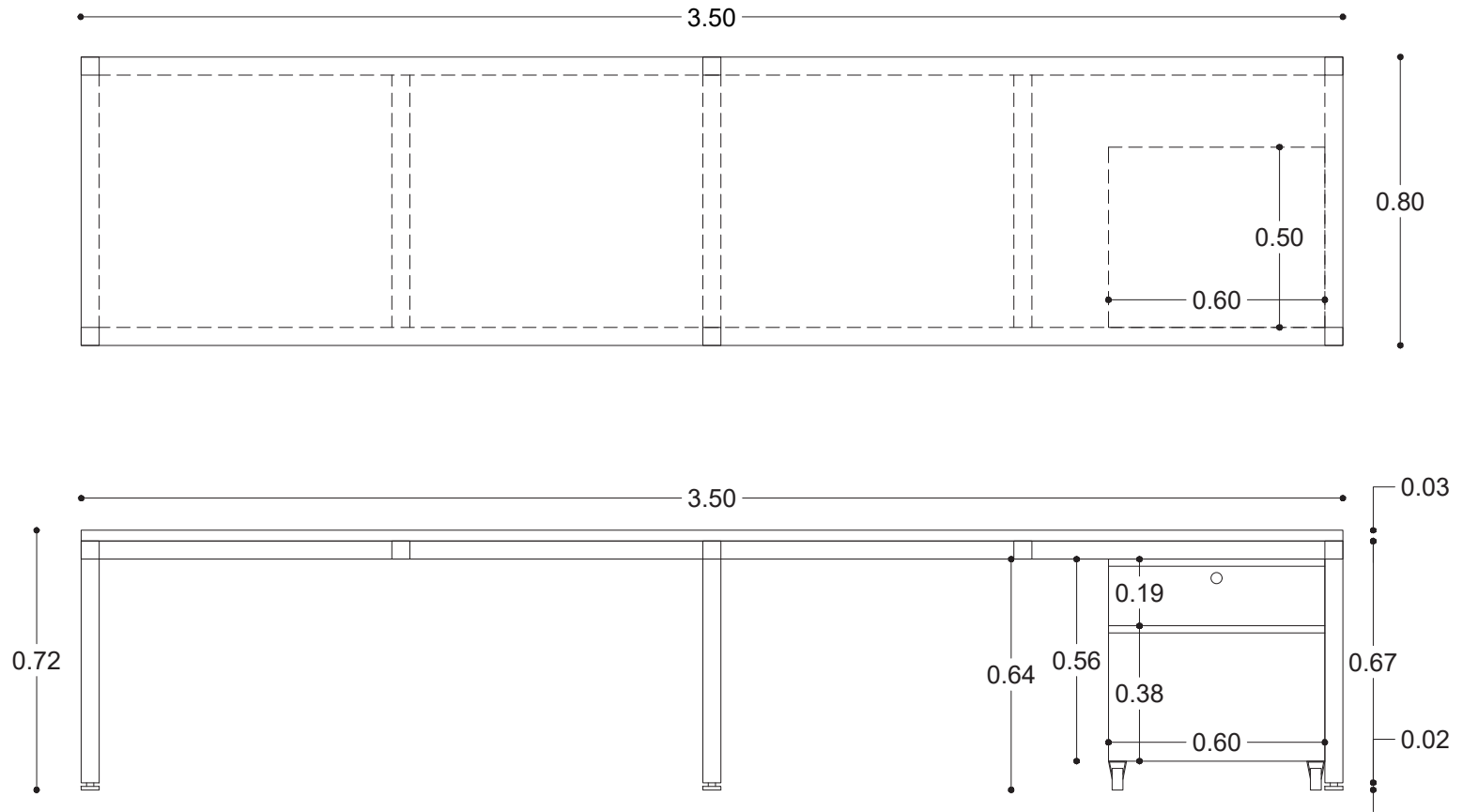

MC 1.19

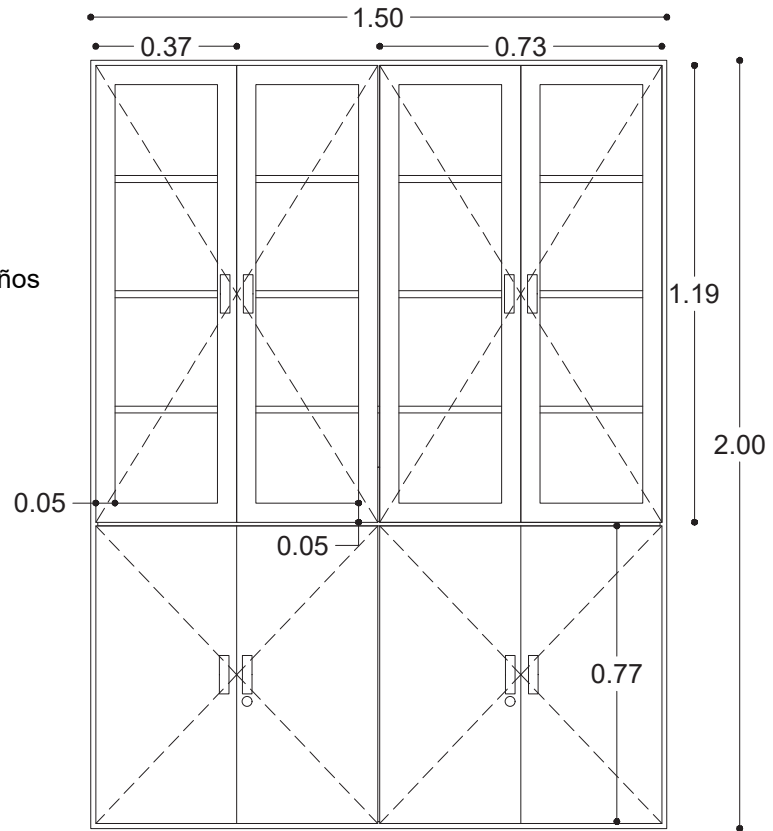
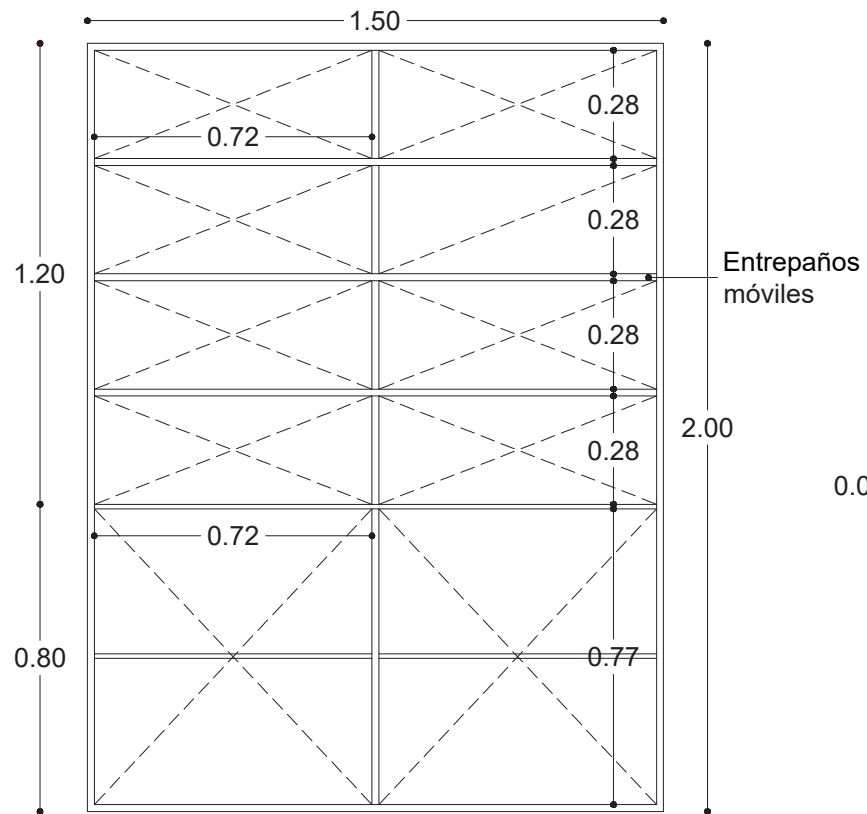
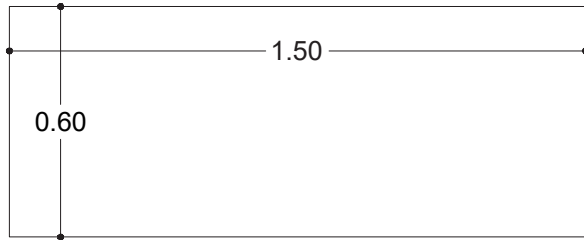

MC 1.20

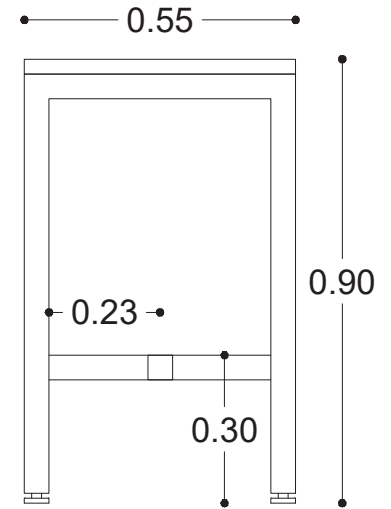
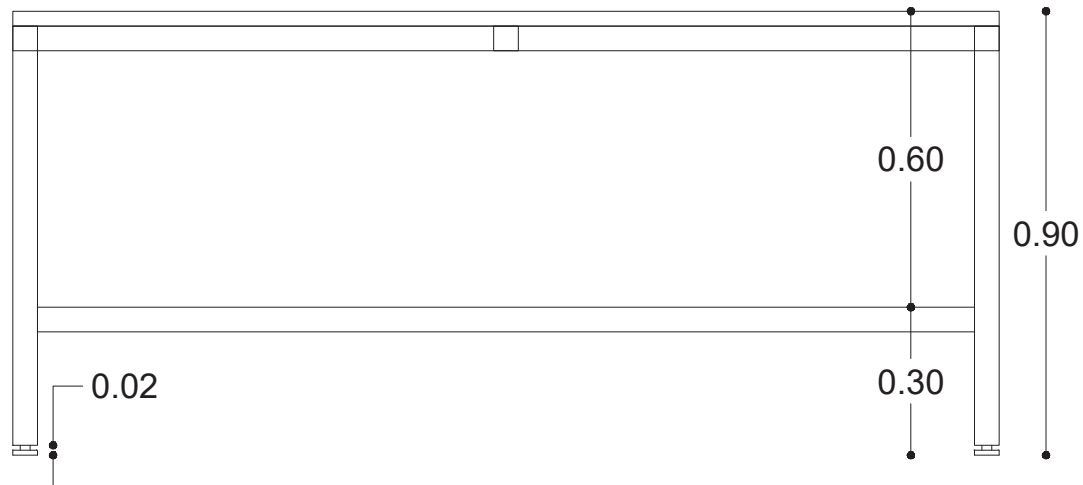
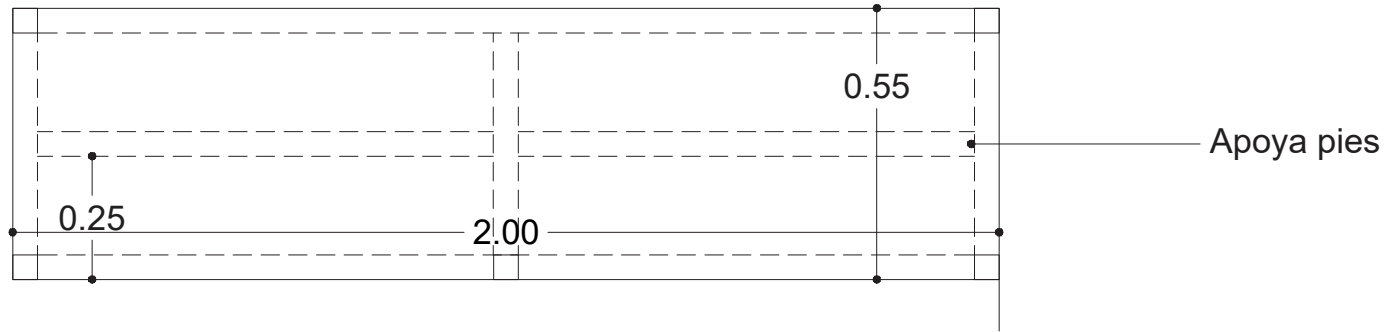

MC 1.21

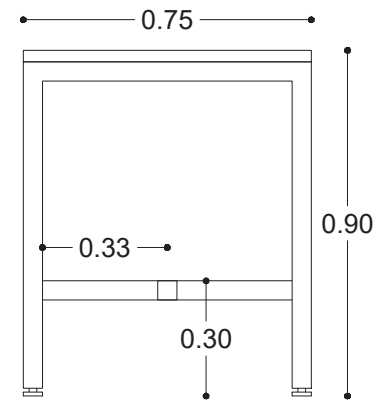
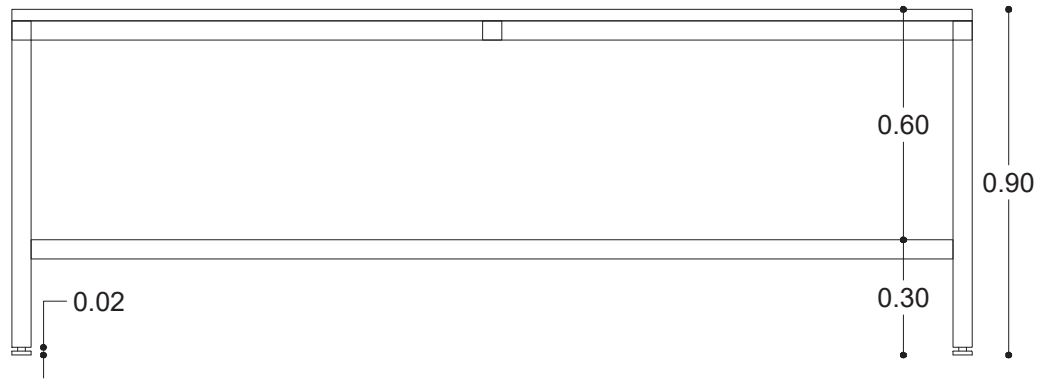
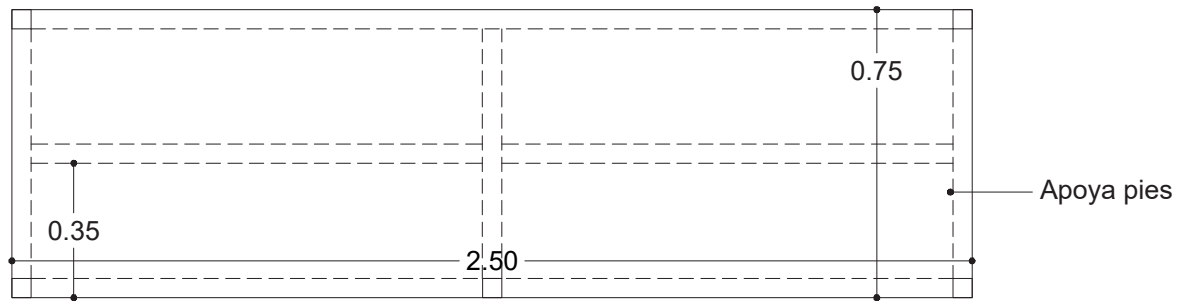

MC 1.22

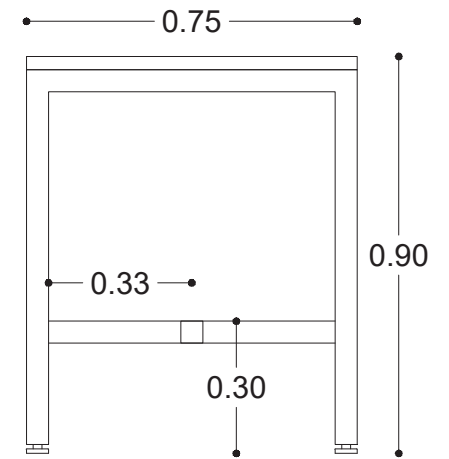
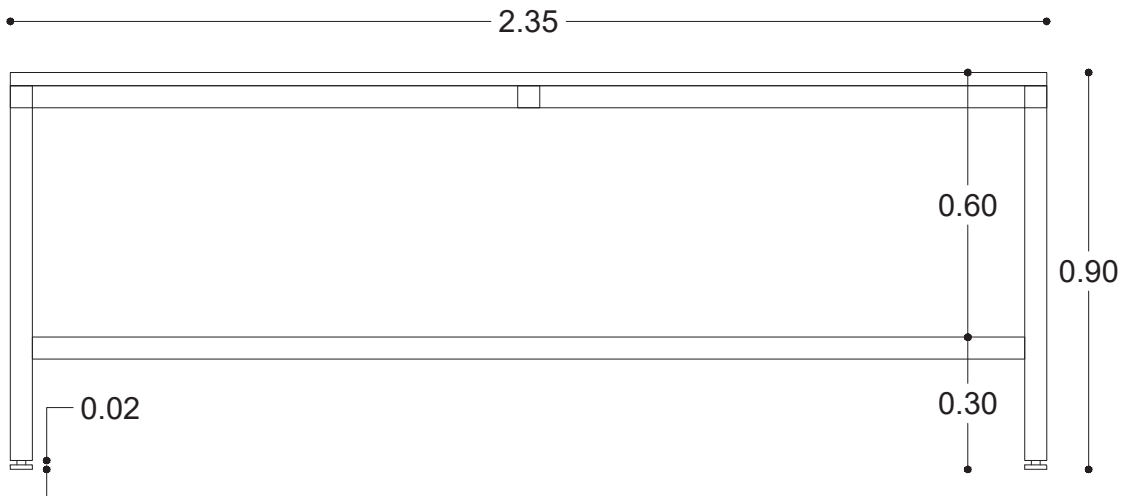
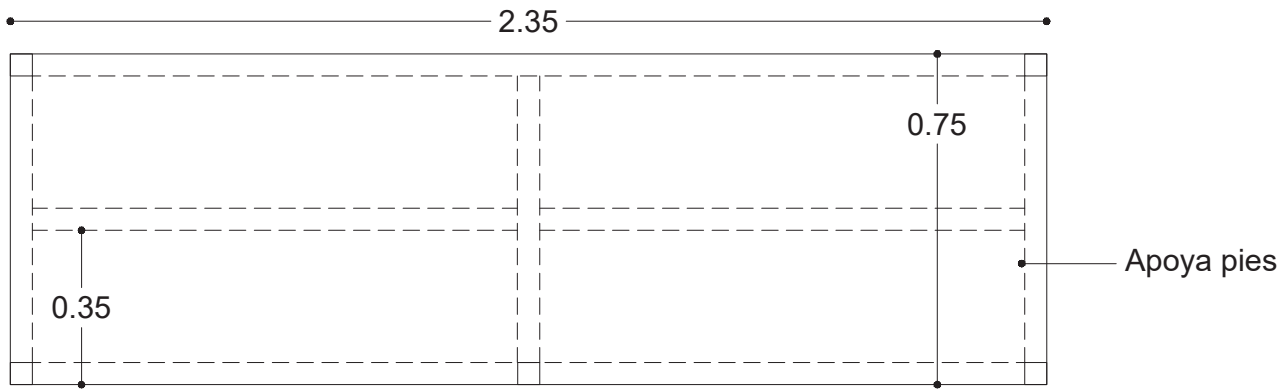

MC 1.23

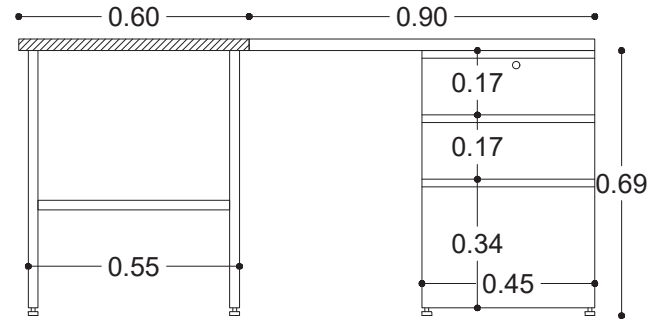
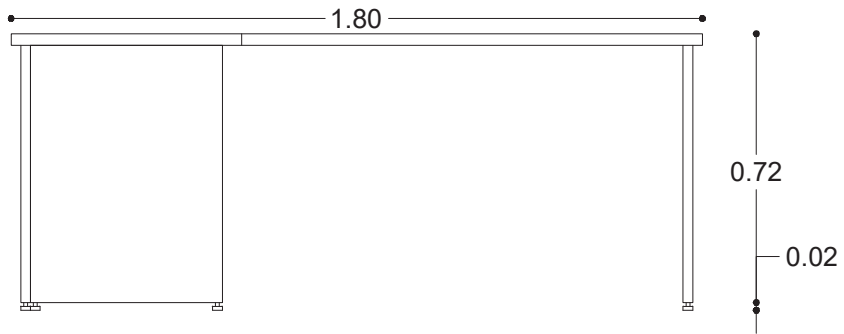
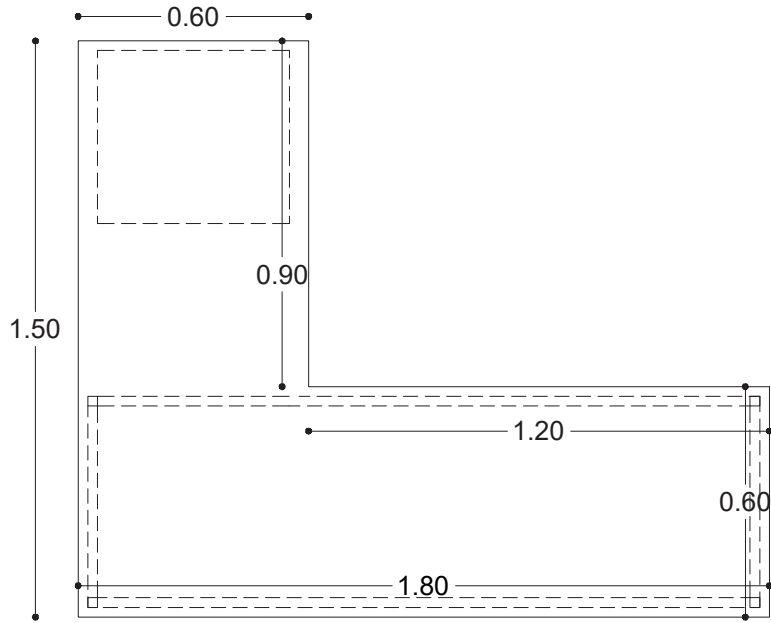

MC 1.24

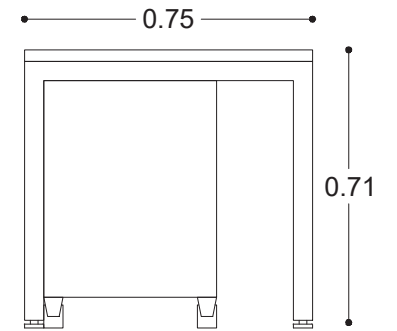
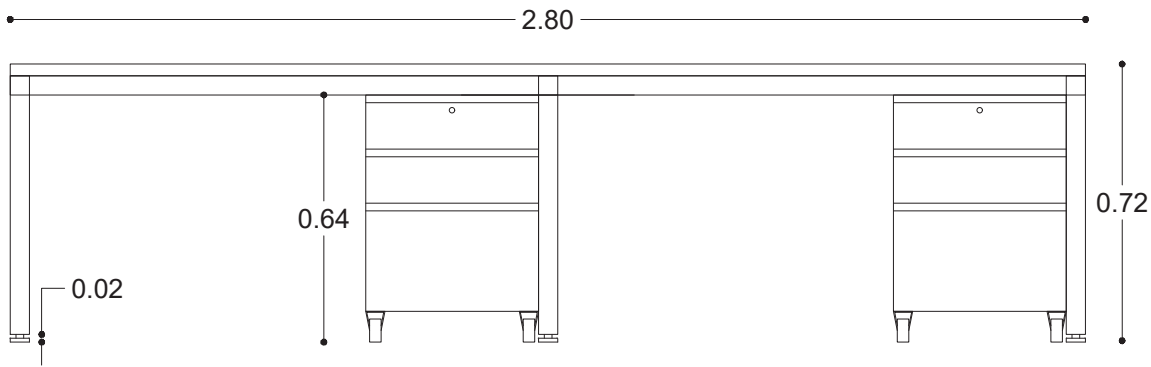
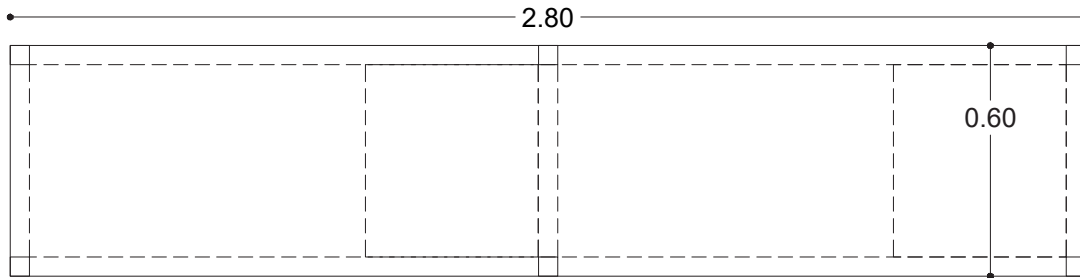

MC 1.25

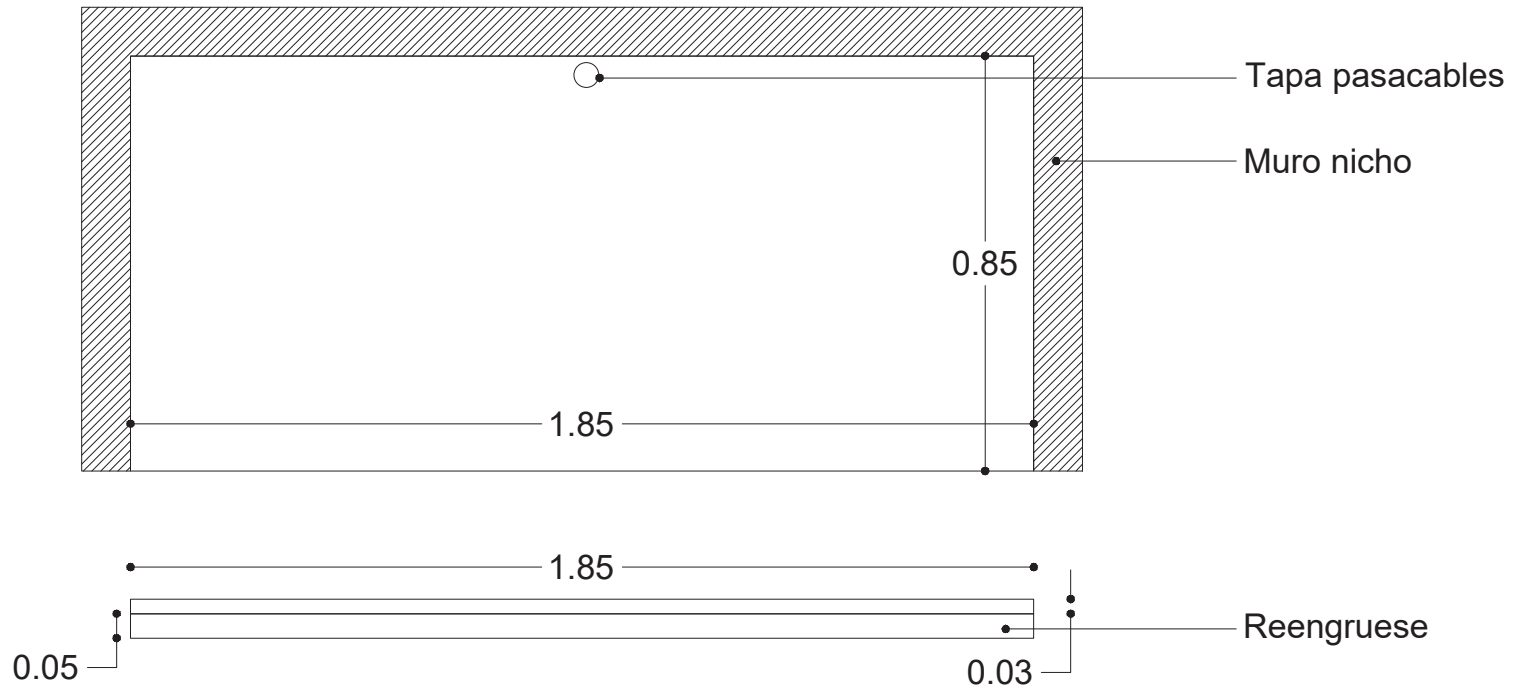

MC 1.26

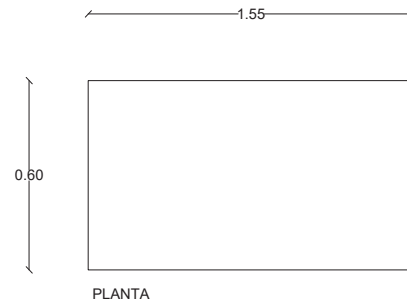
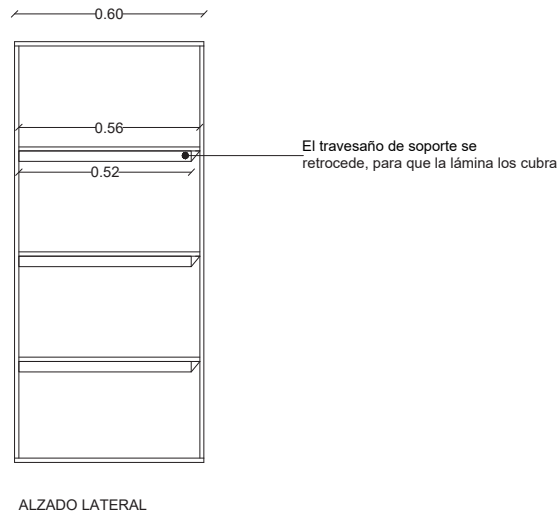
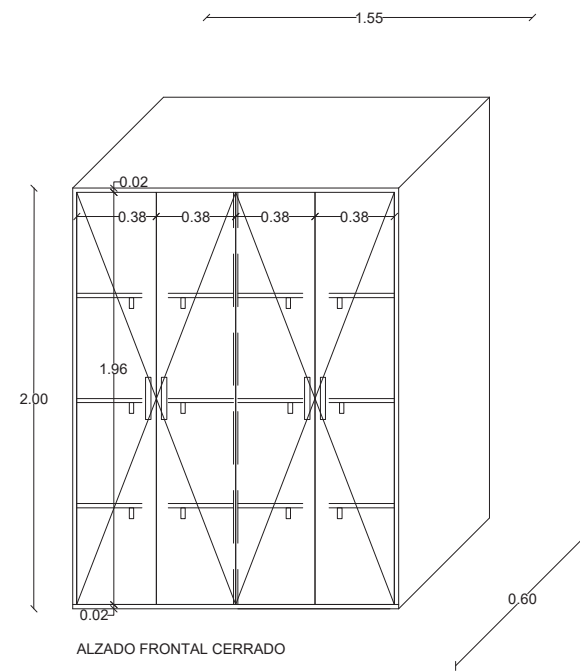
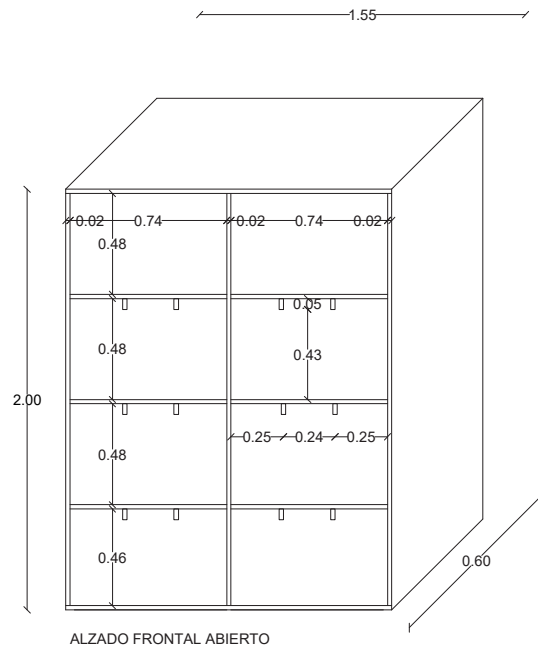

MC 1.27

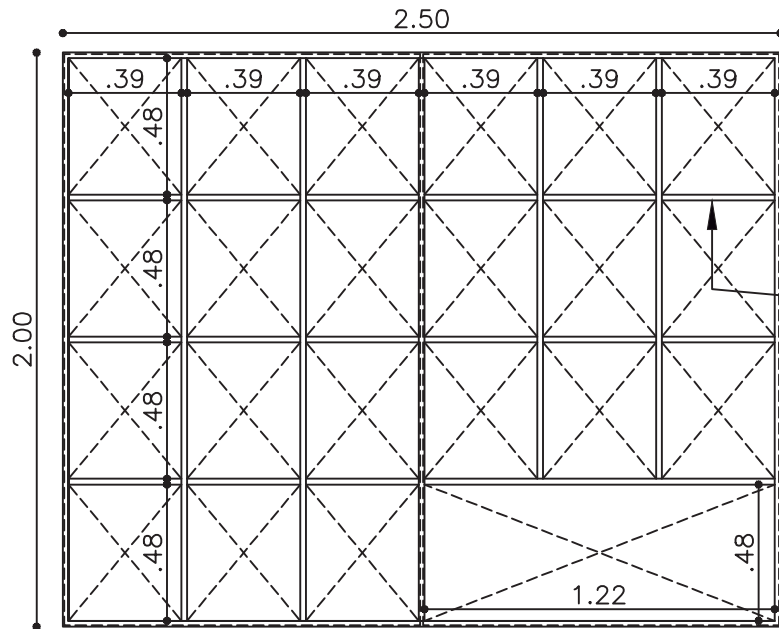
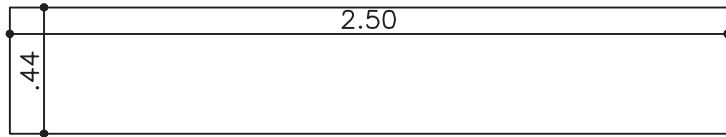

Entrepaños fijos

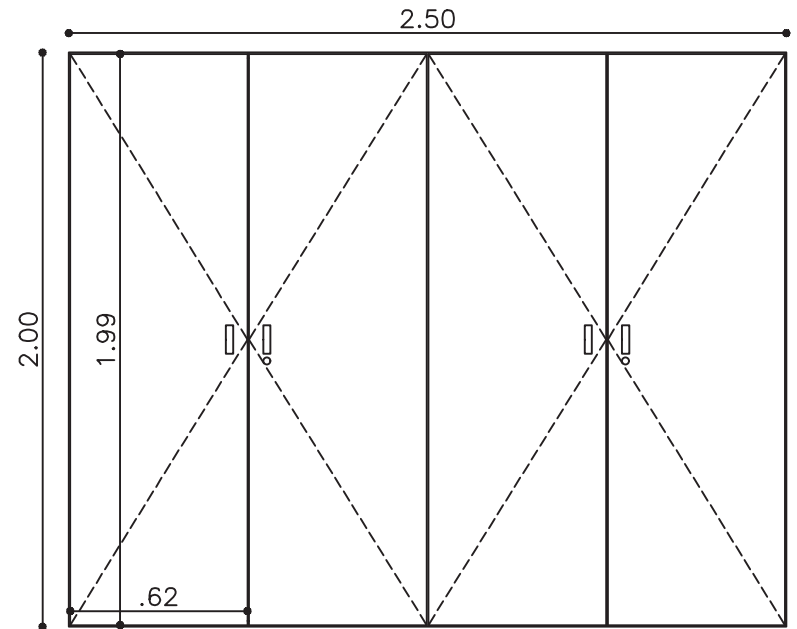

MC 1.28

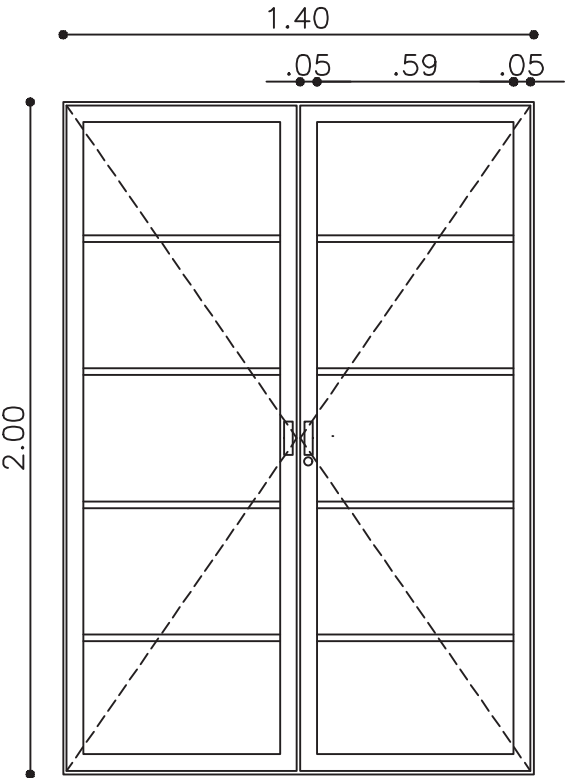
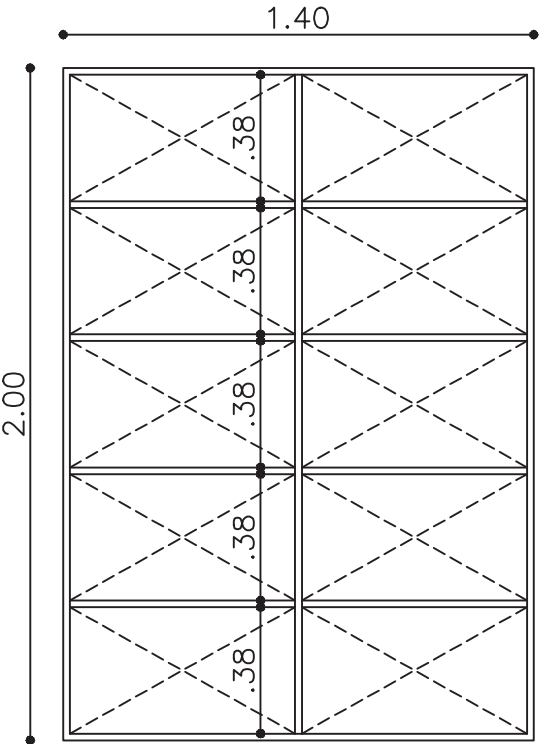
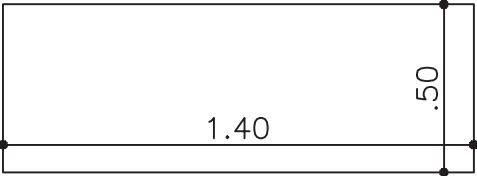

MC 1.29

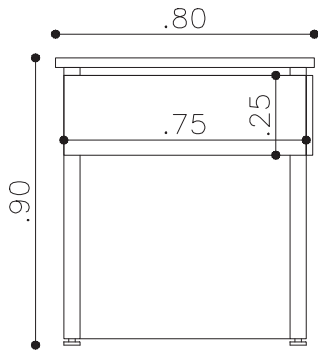
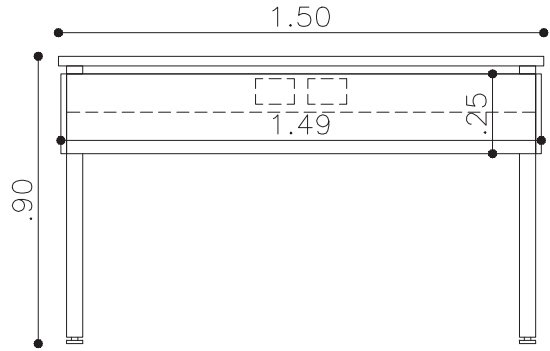
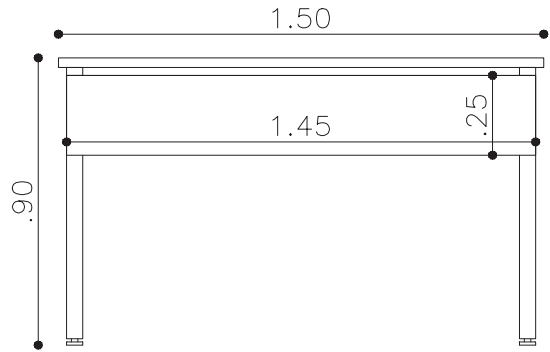
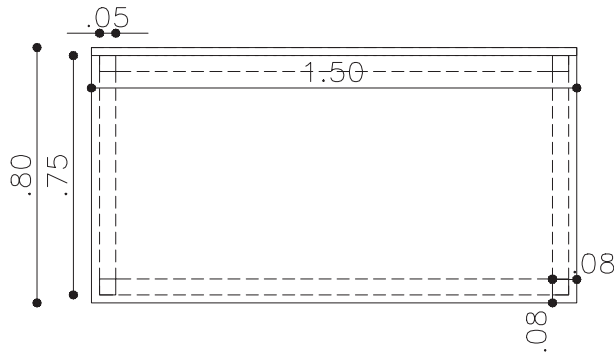

MC 1.30

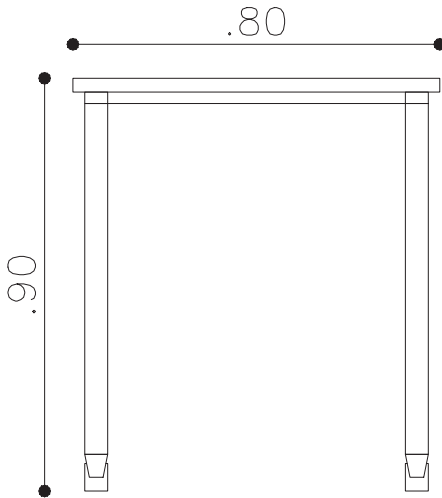
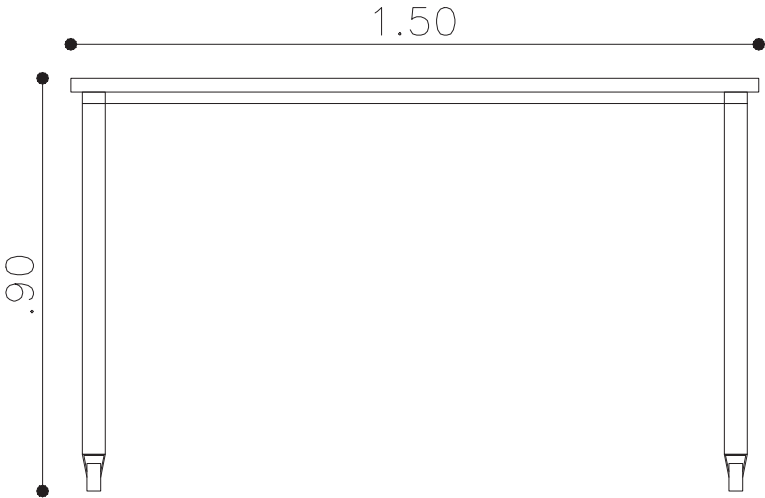

MC 1.31

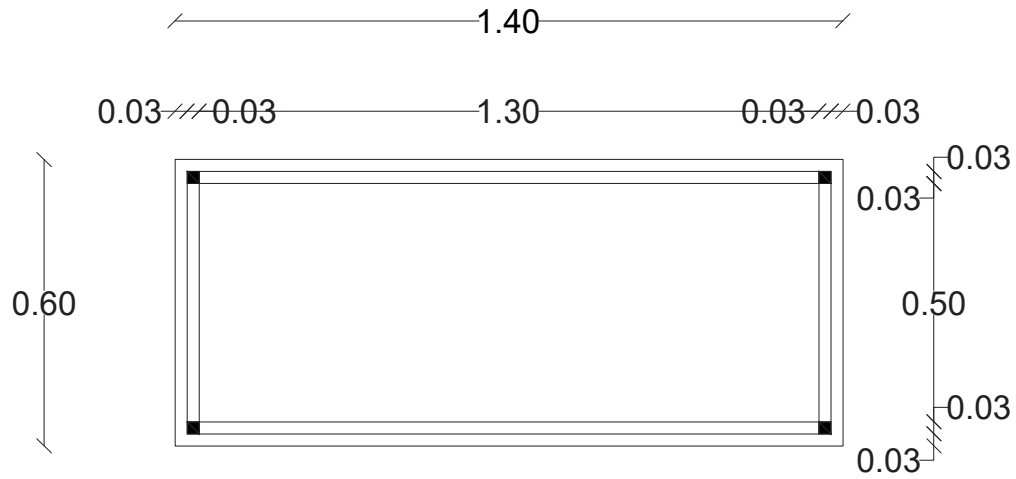

PLANTA

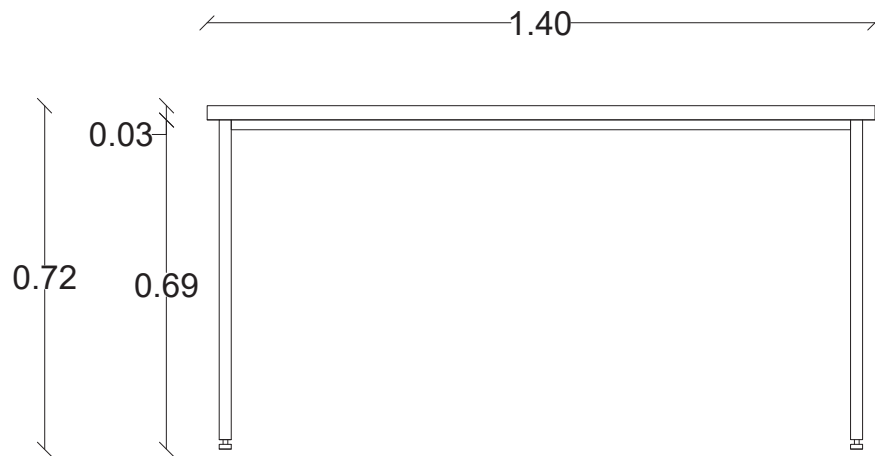

ALZADO FRONTAL

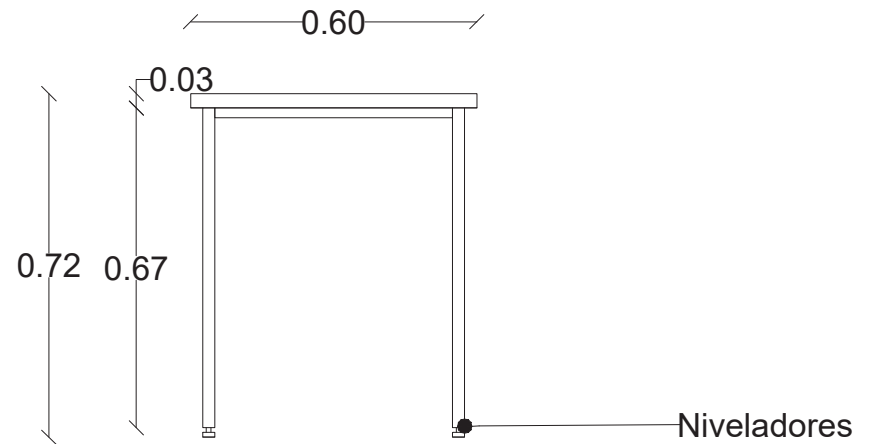

ALZADO LATERAL

MC 1.32

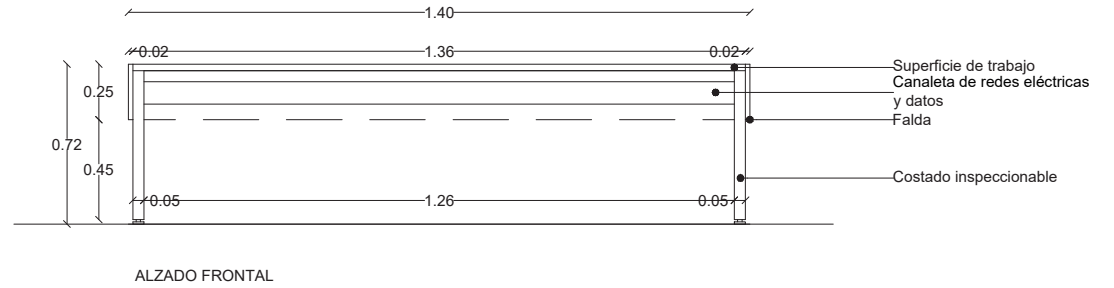
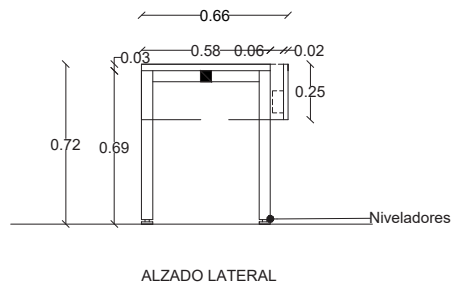
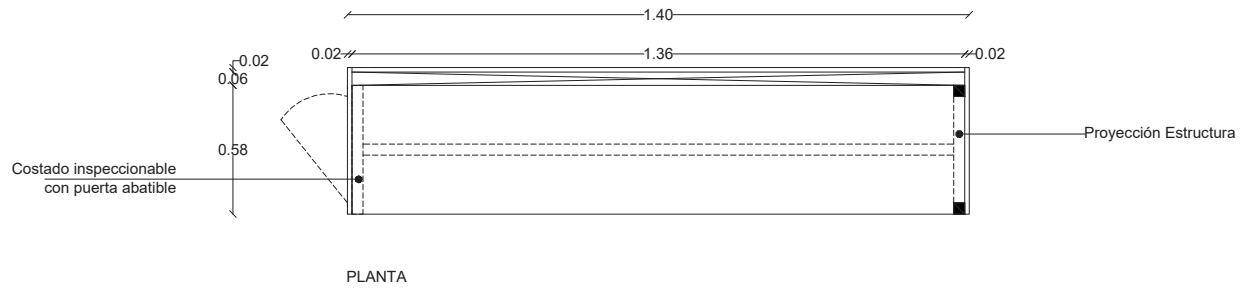

MC 1.33

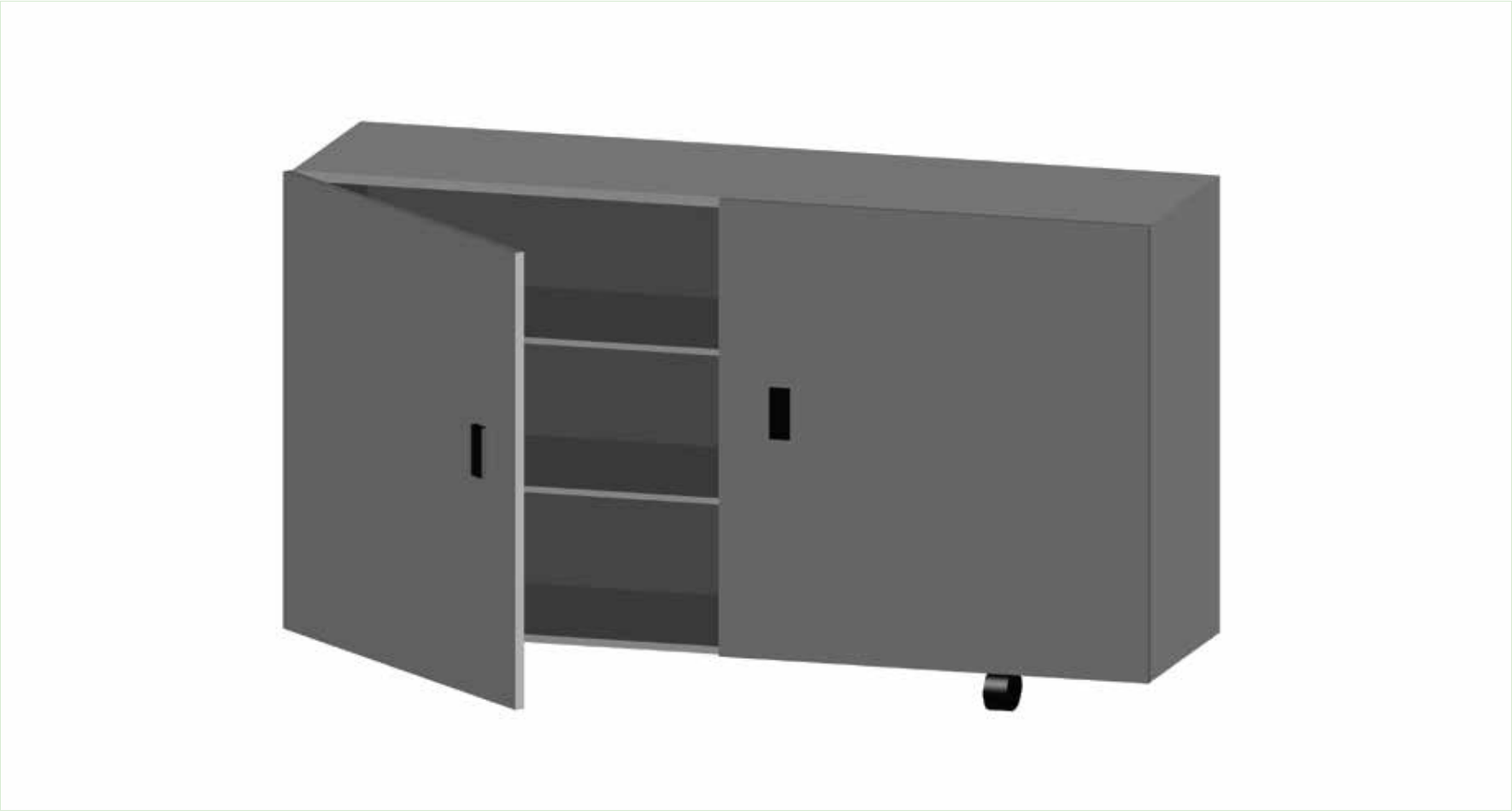

MC 1.34

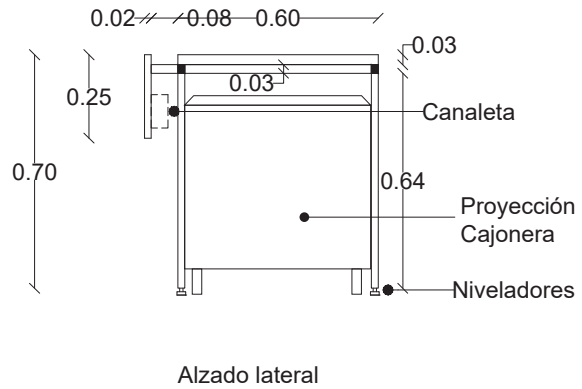
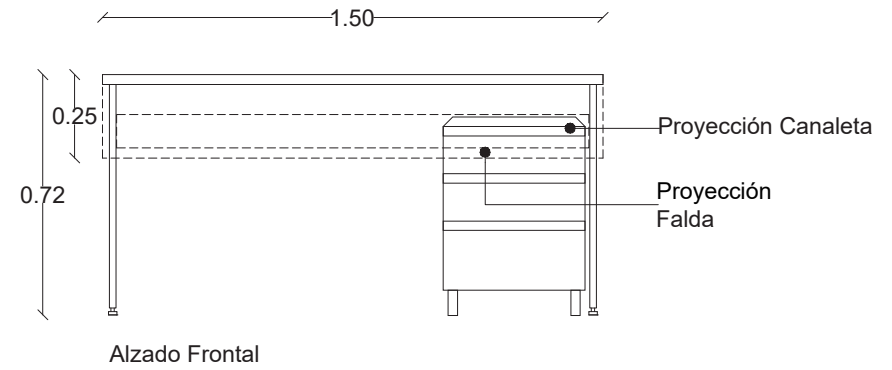
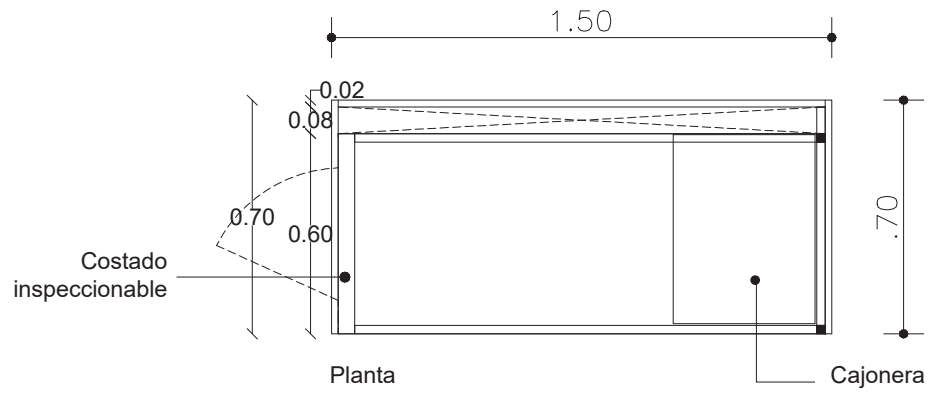

MC 1.35

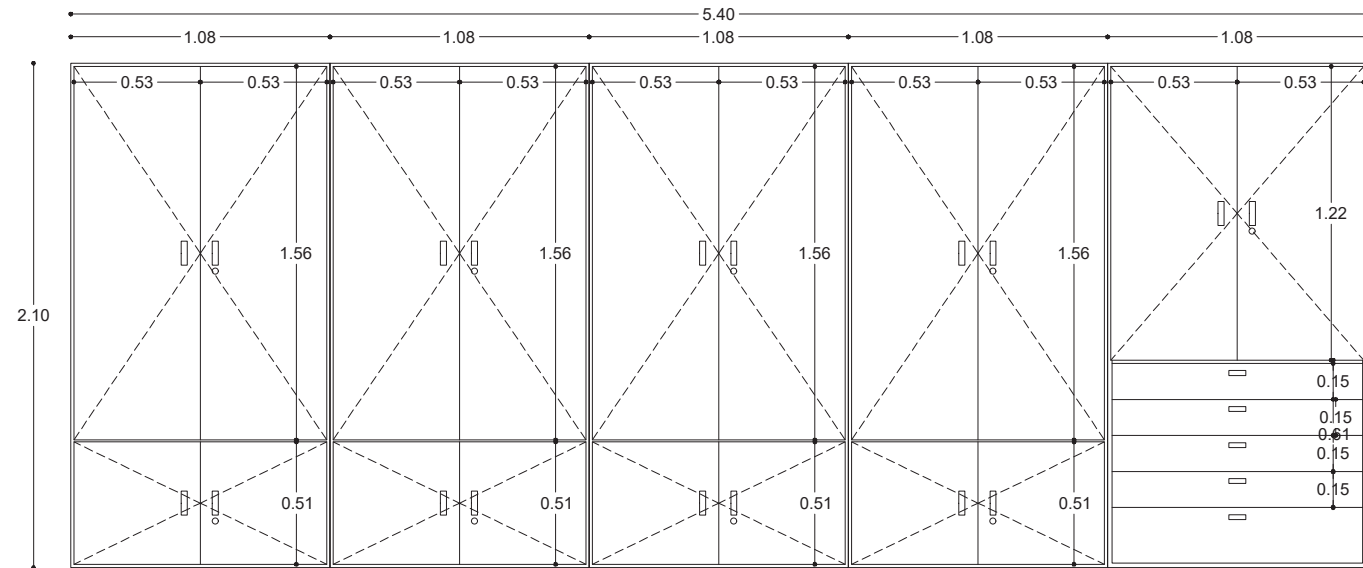
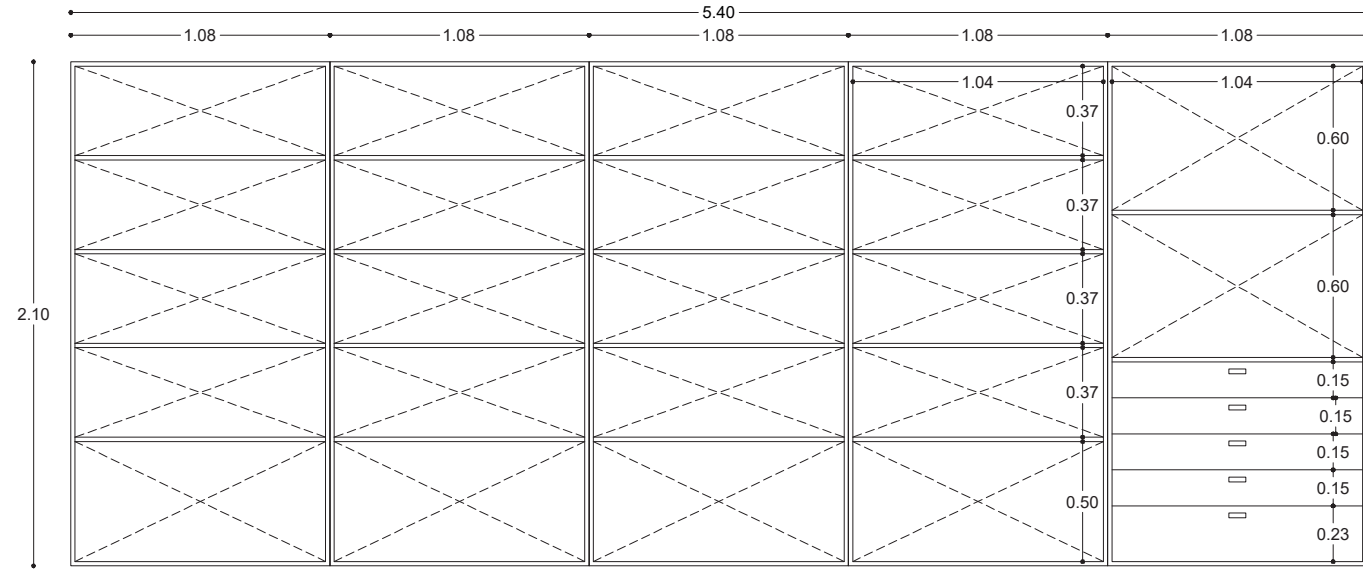
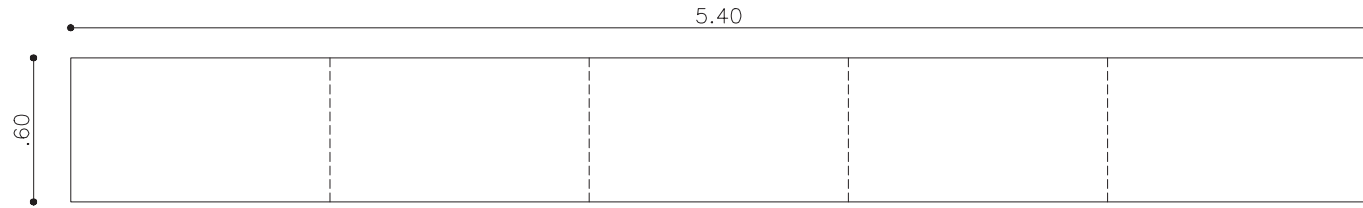

MC 1.36

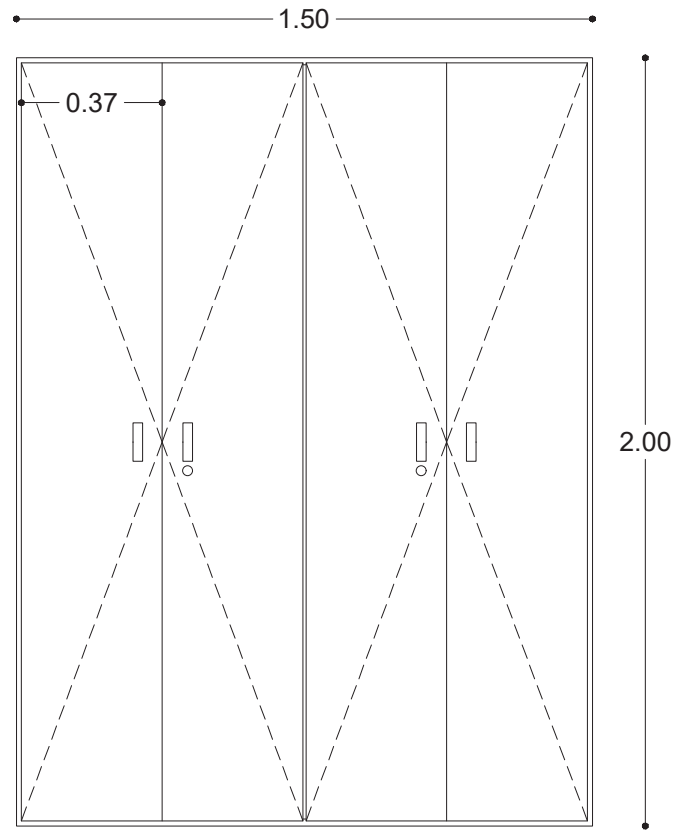
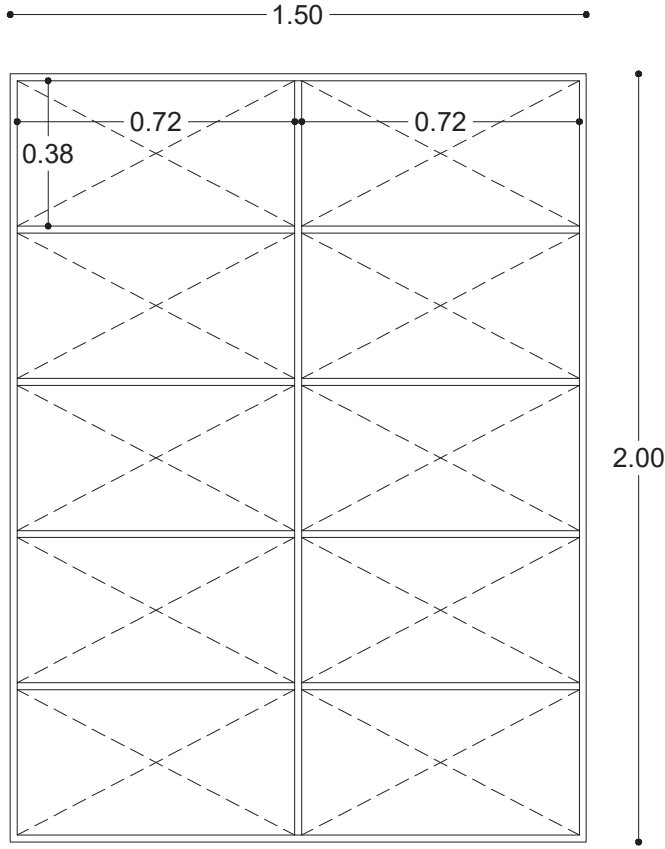
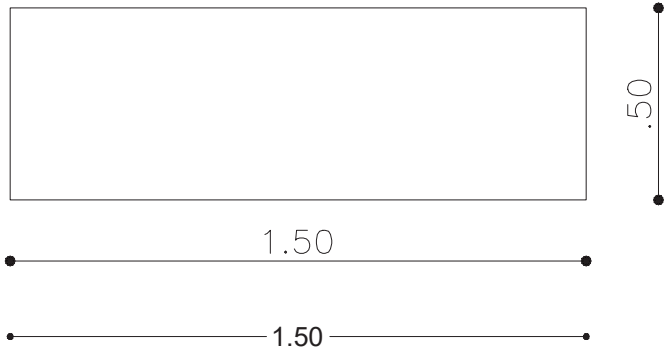

MC 1.37

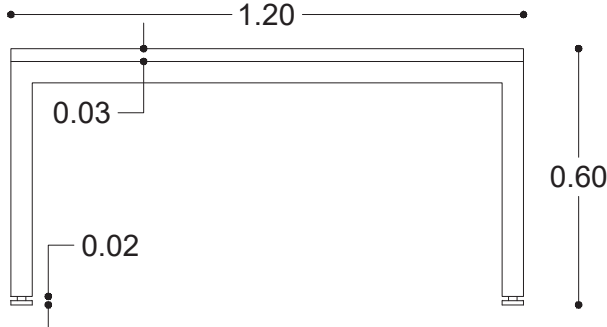
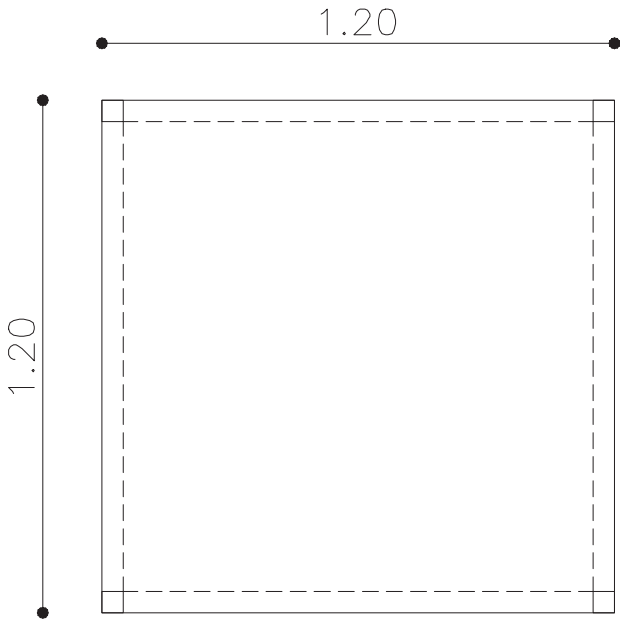

MC 1.38

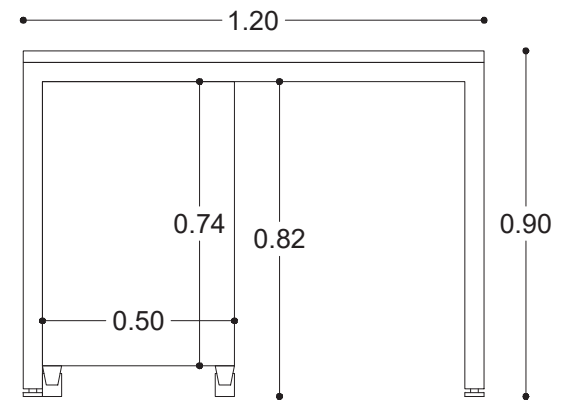
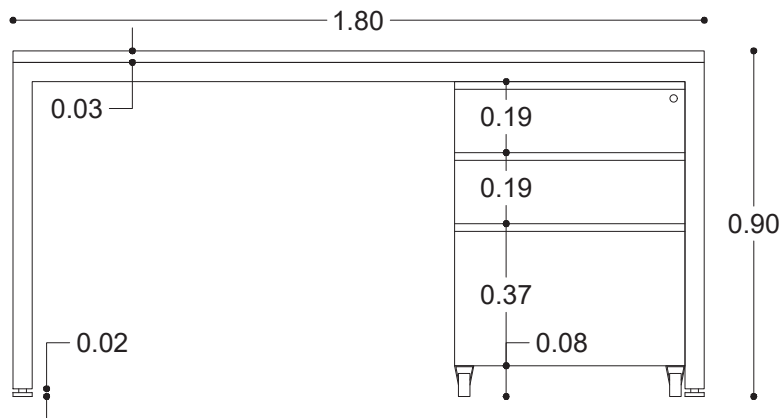
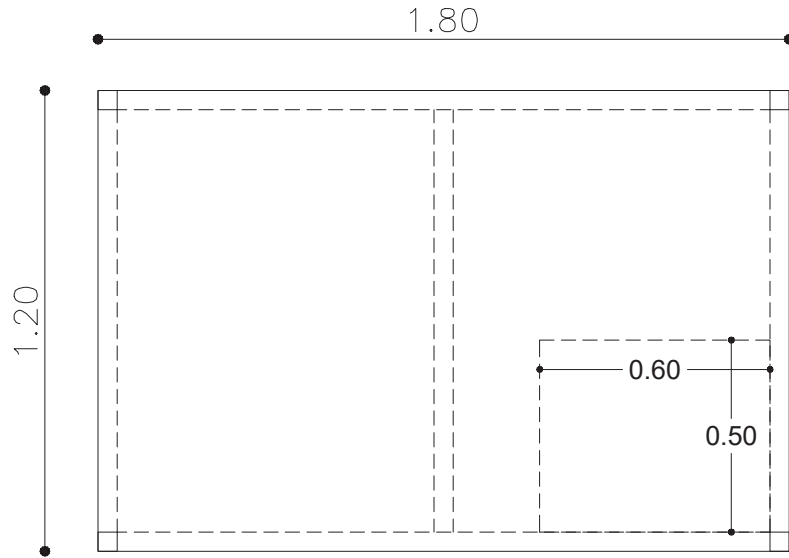

MC 1.39

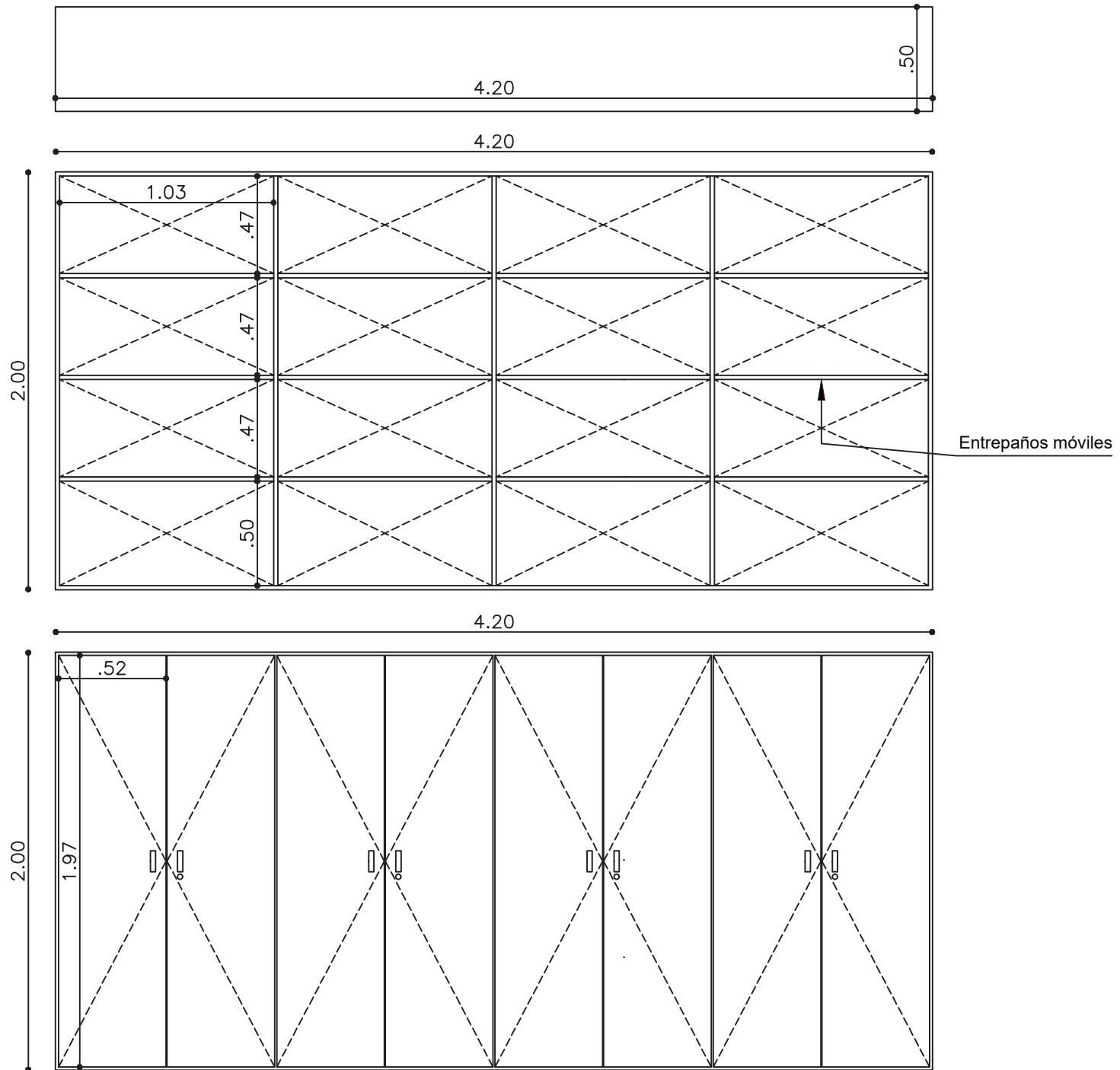

MC 1.40

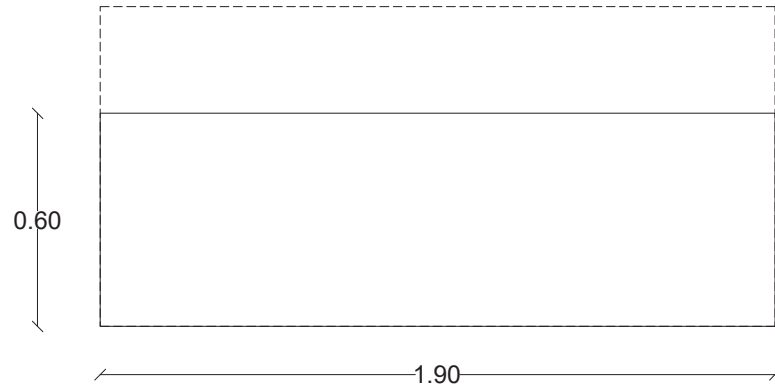

PLANTA

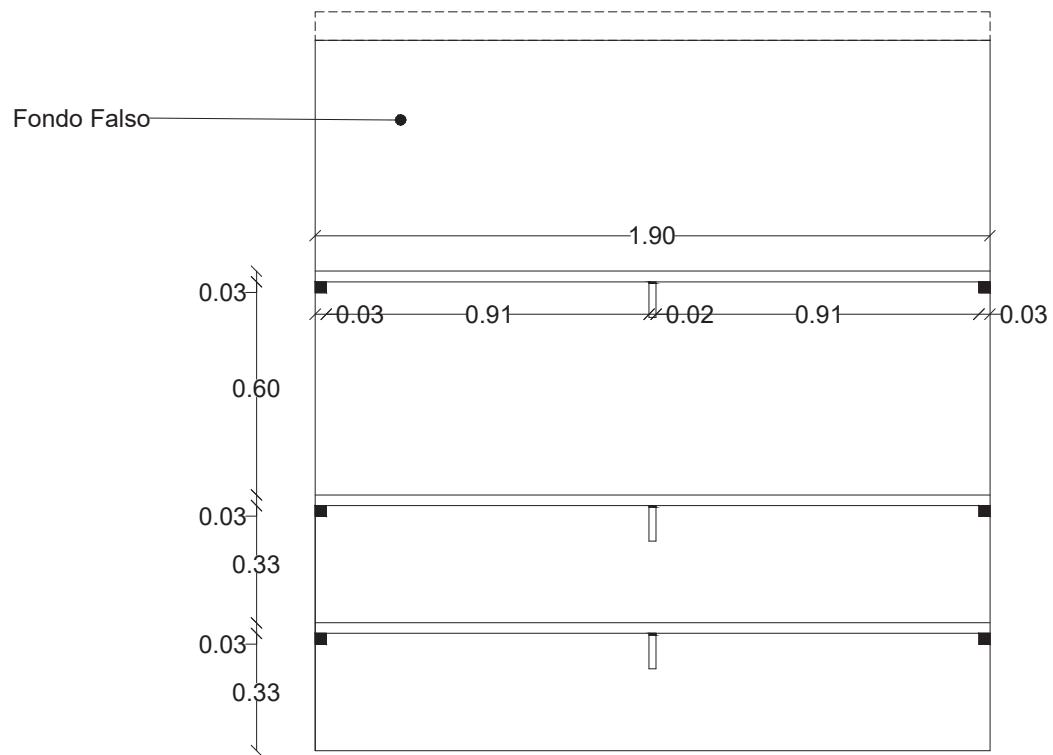

ALZADO FRONTAL

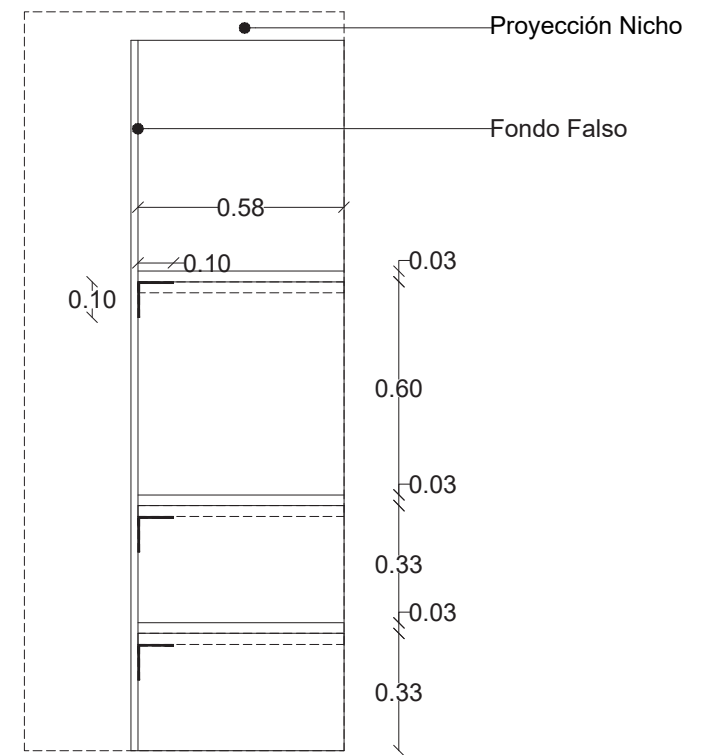

ALZADO LATERAL

MC 1.41

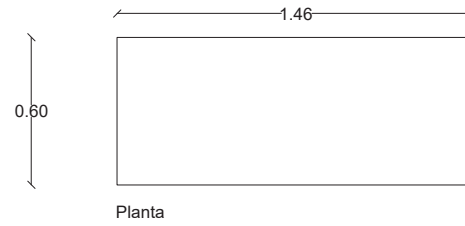
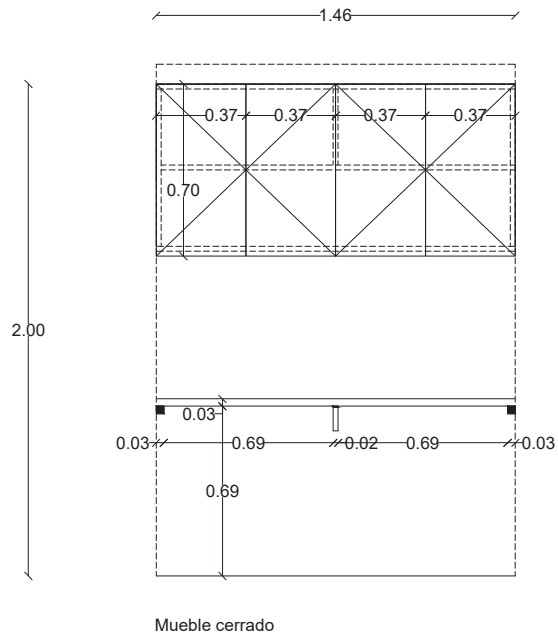
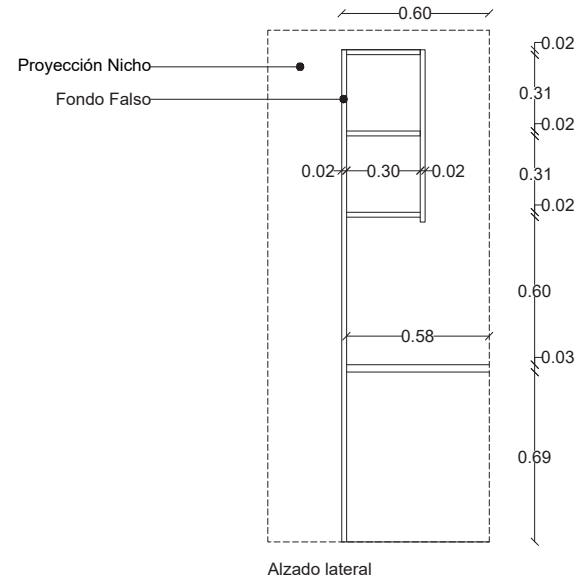
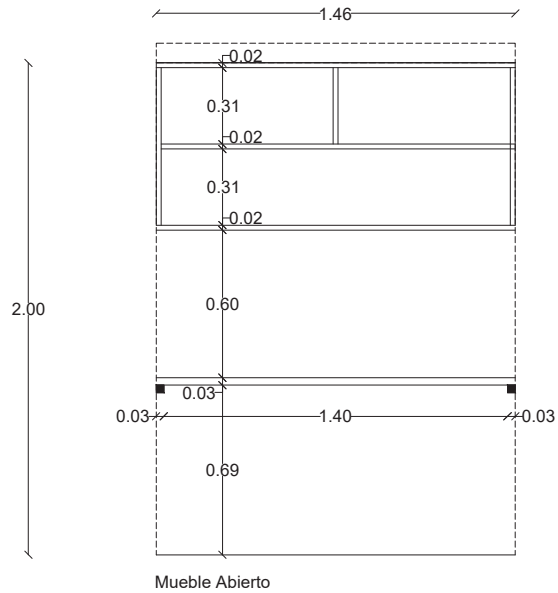

MC 1.42

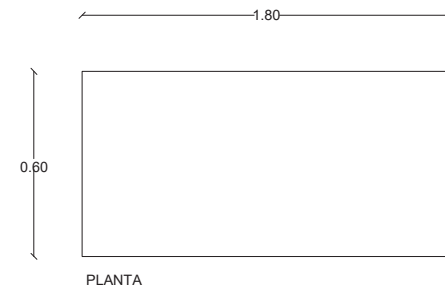
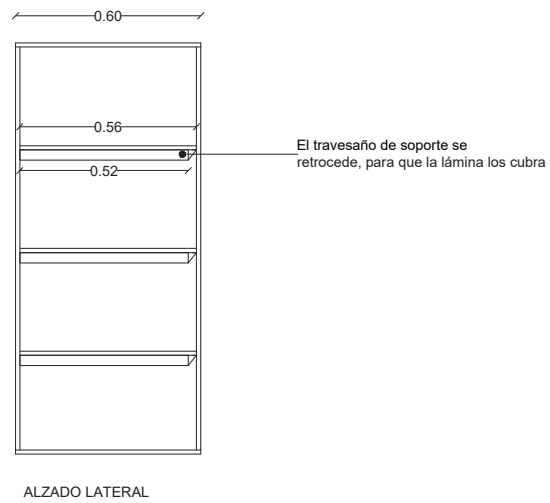
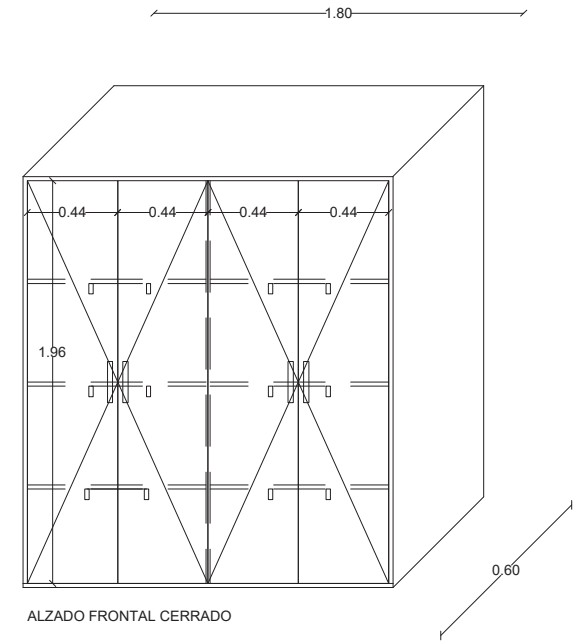
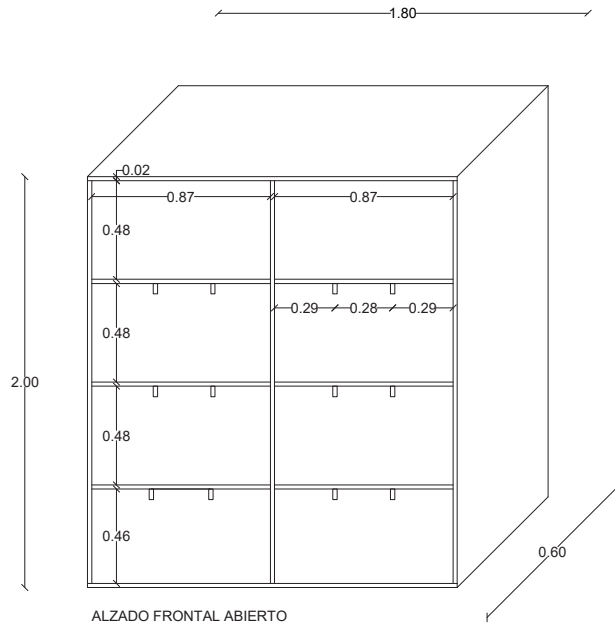

MC 1.43

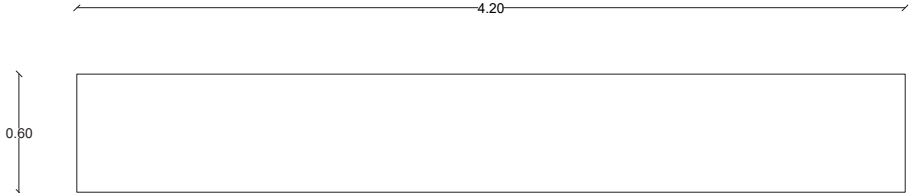

PLANTA

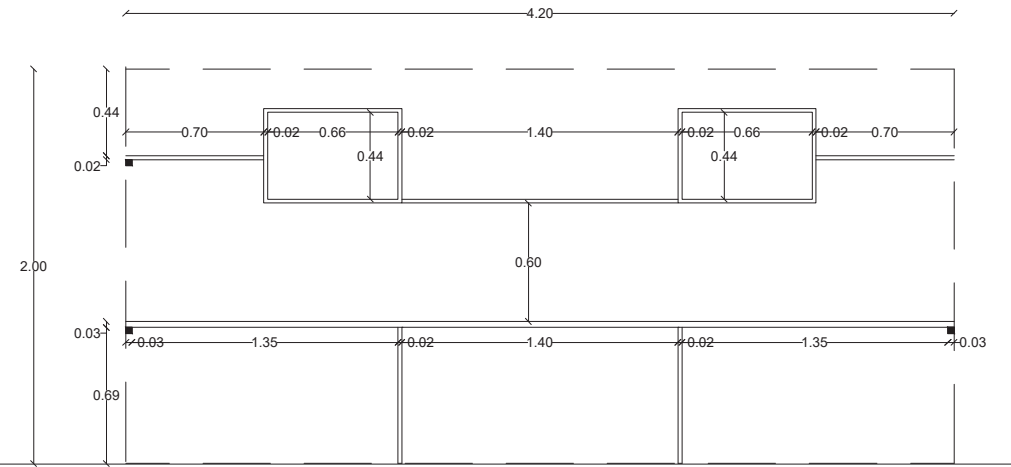

ALZADO FRONTAL

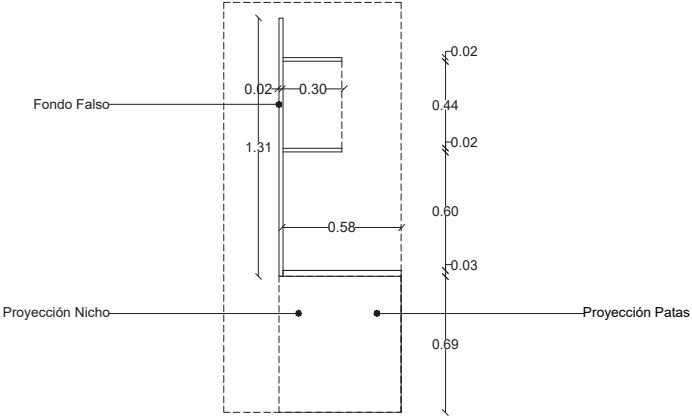

ALZADO LATERAL

MC 1.44

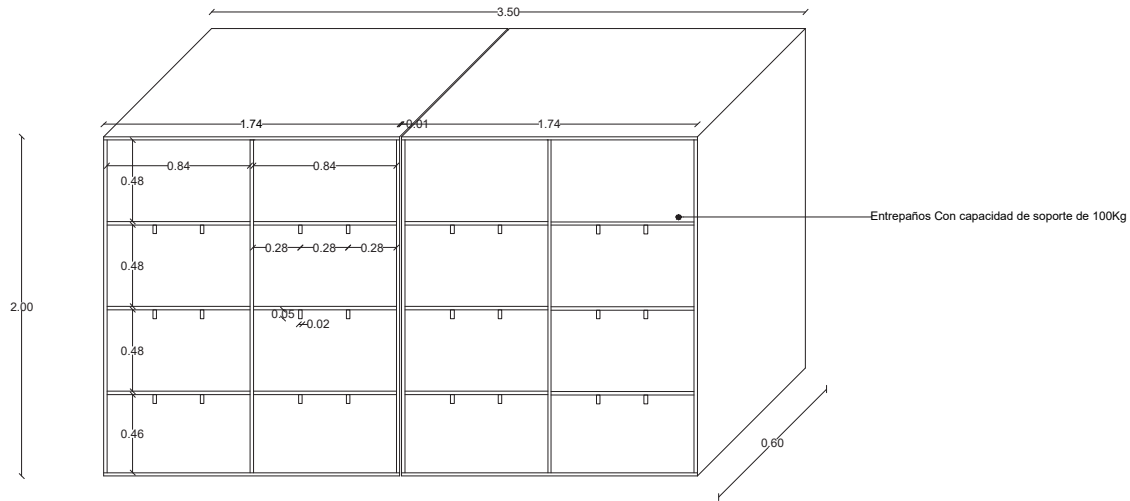

Mueble Abierto

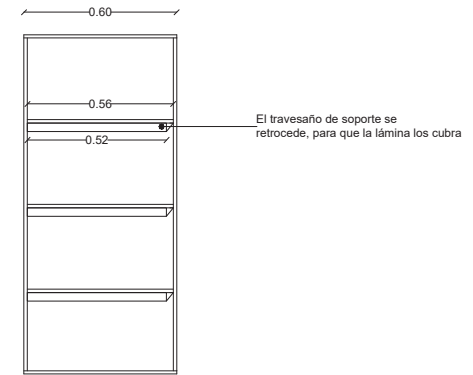

Vista Lateral

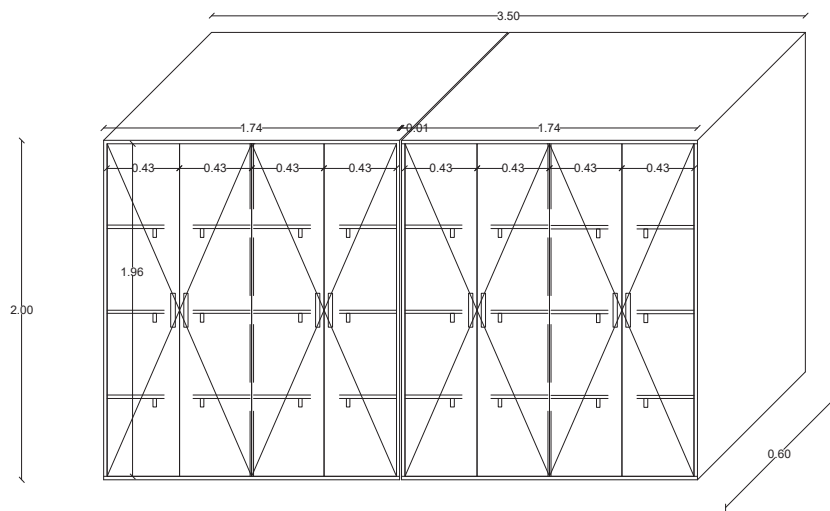

Mueble Cerrado

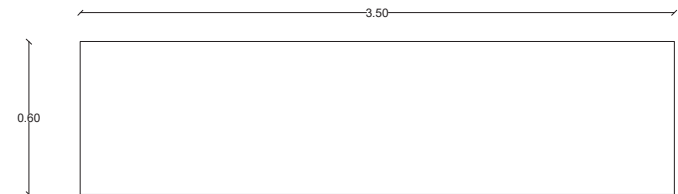

Planta

MC 1.45

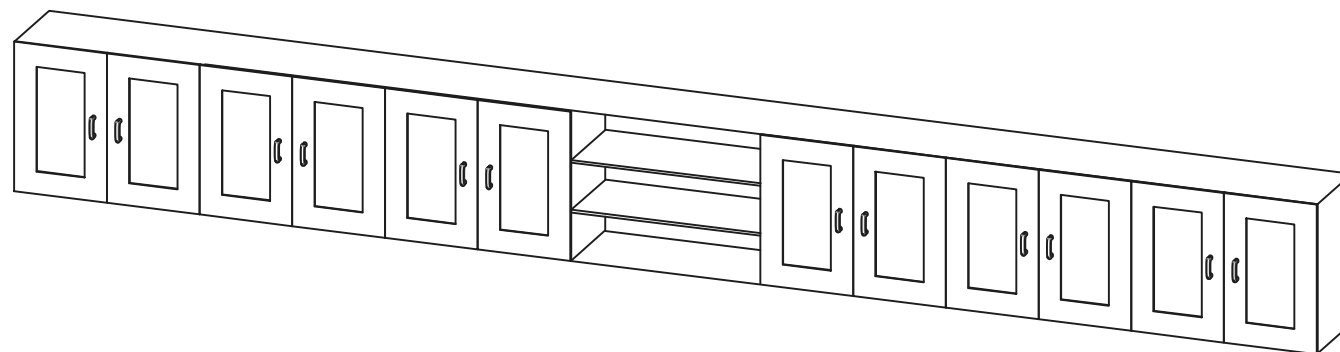

PLANTA



MUEBLE CERRADO

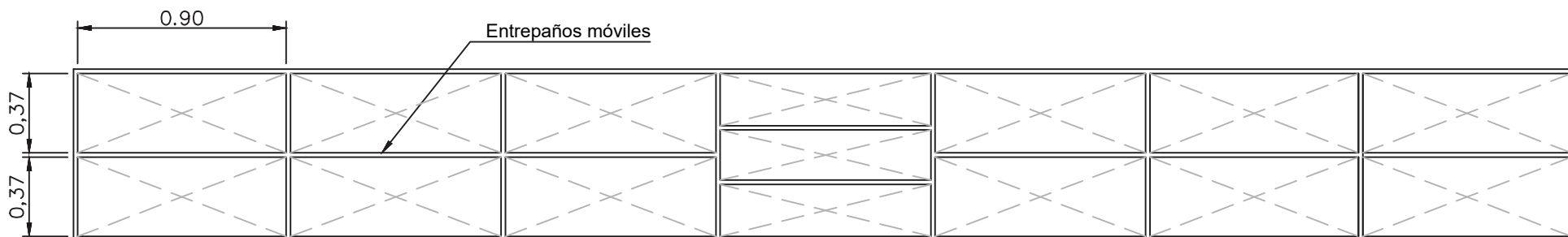
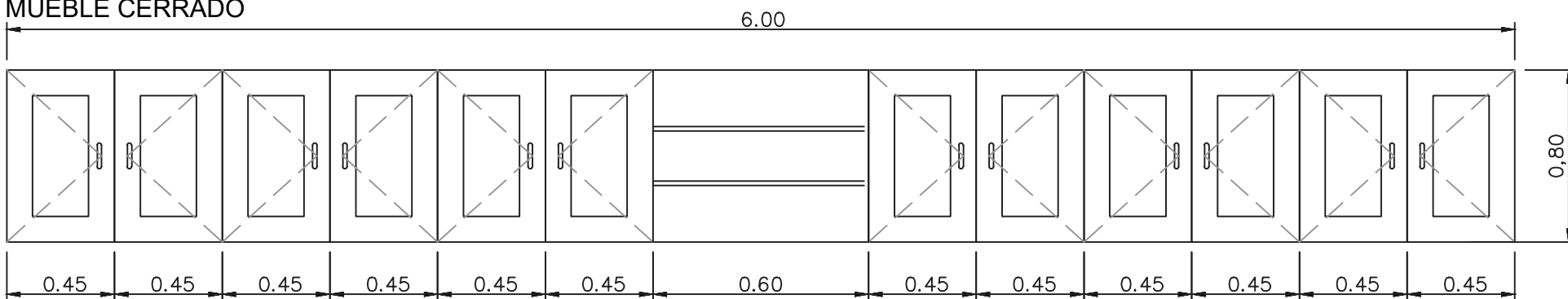

MUEBLE ABIERTO

MC 1.46

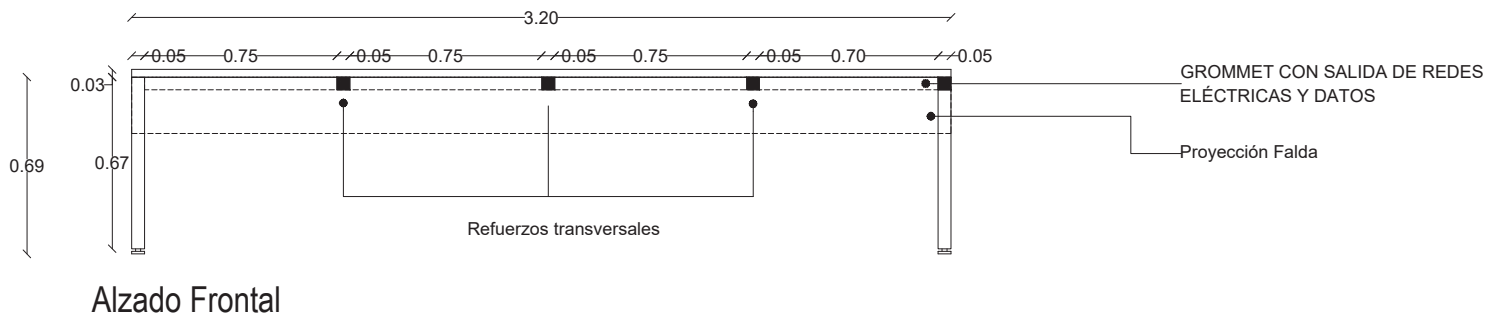
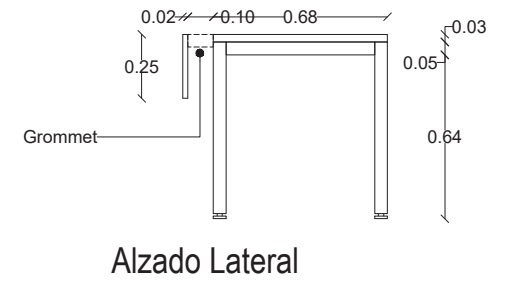
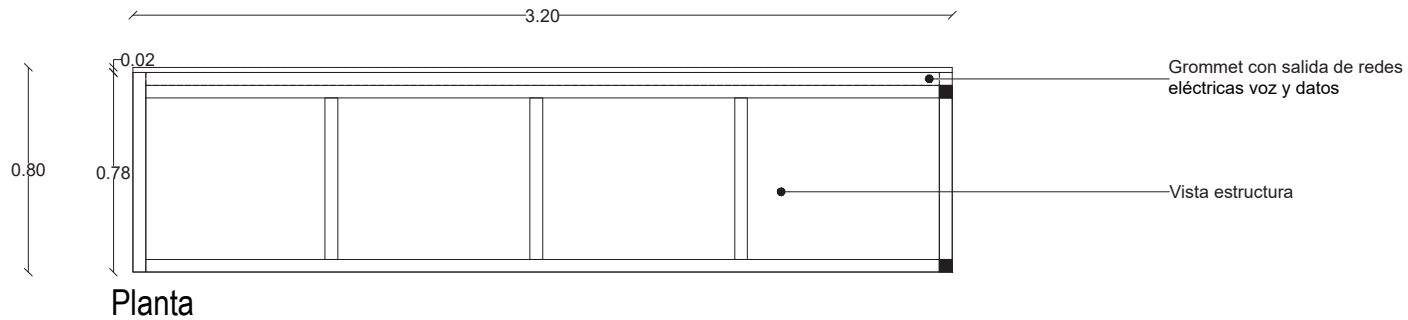

MC 1.47

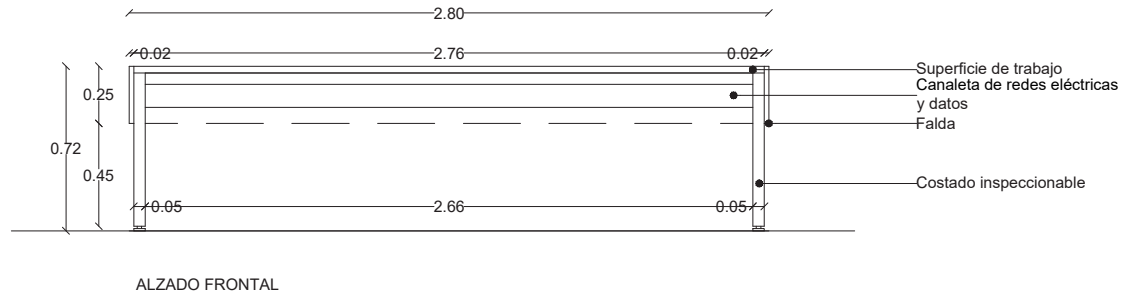
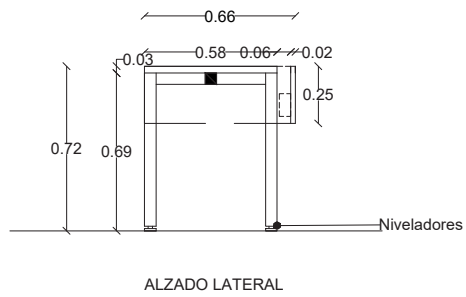
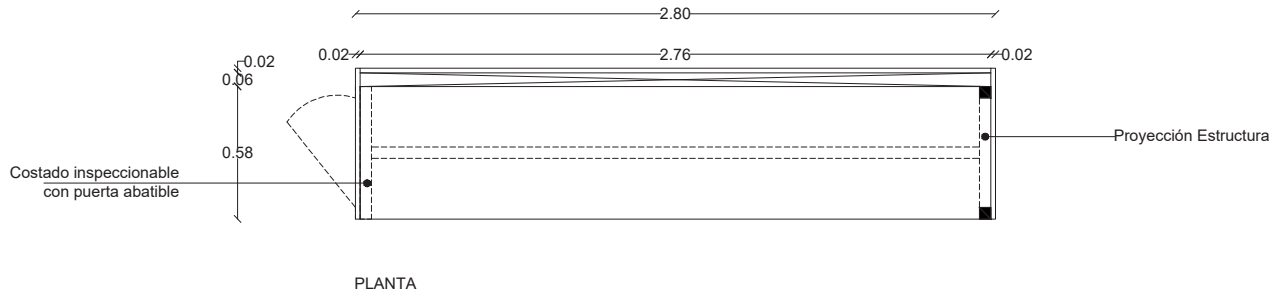

MC 1.48

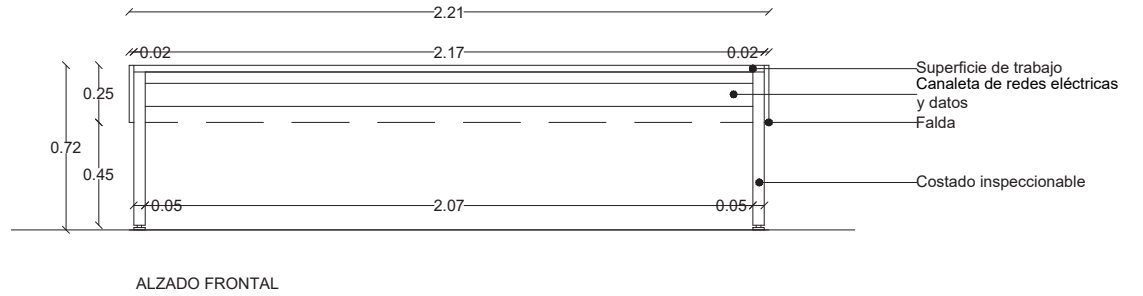
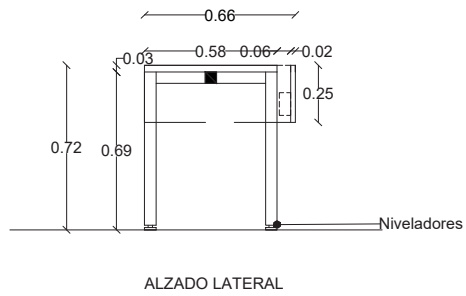
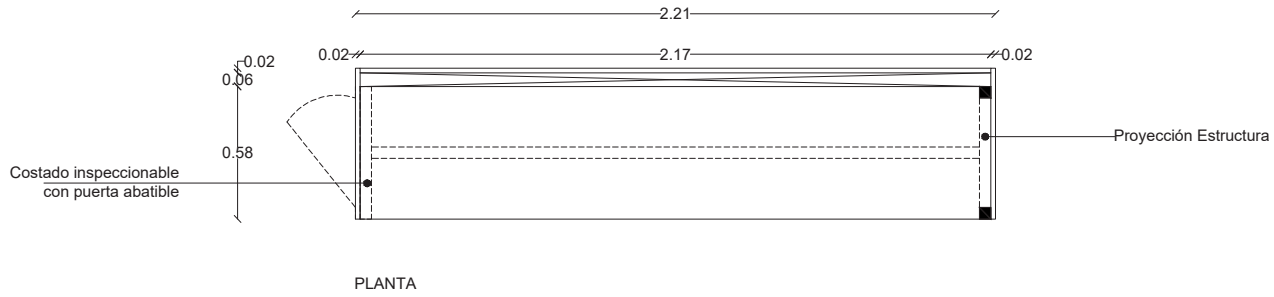

MC 1.49

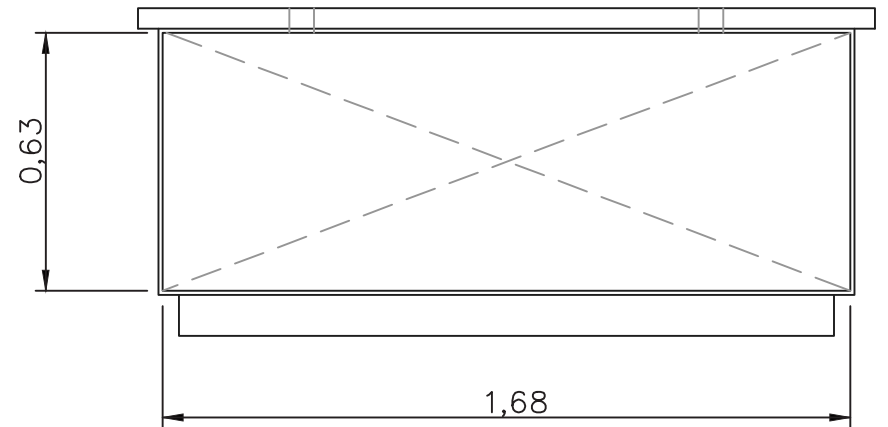
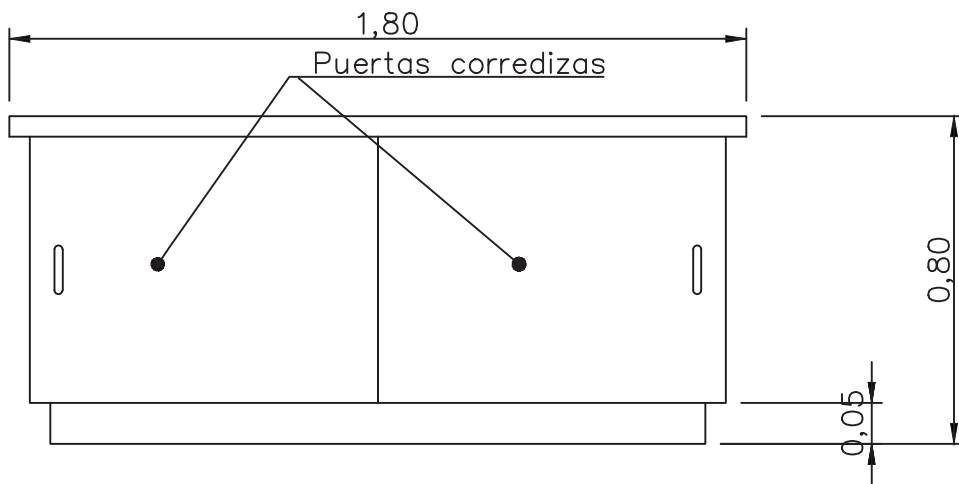
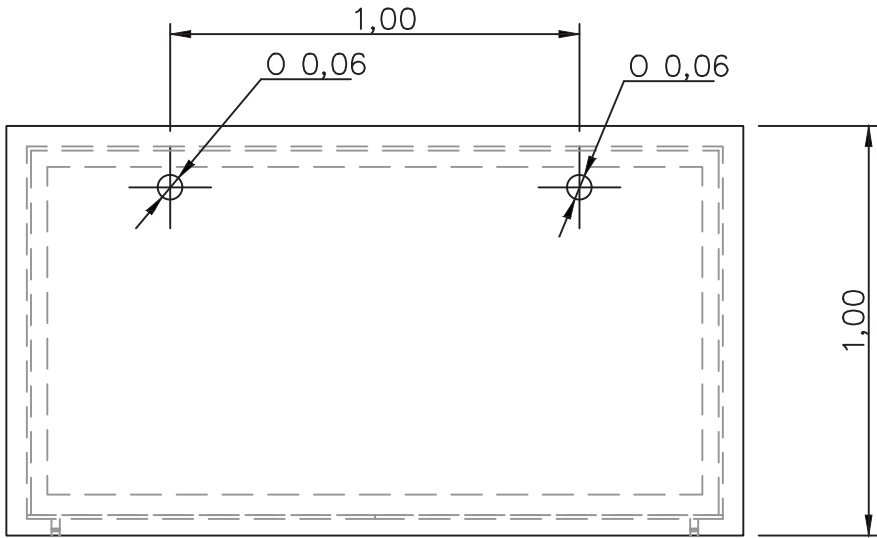
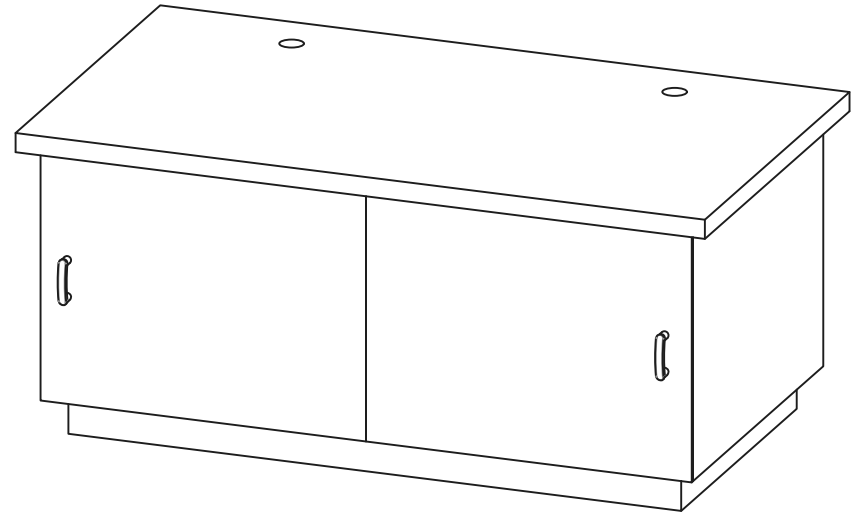

MC 1.50

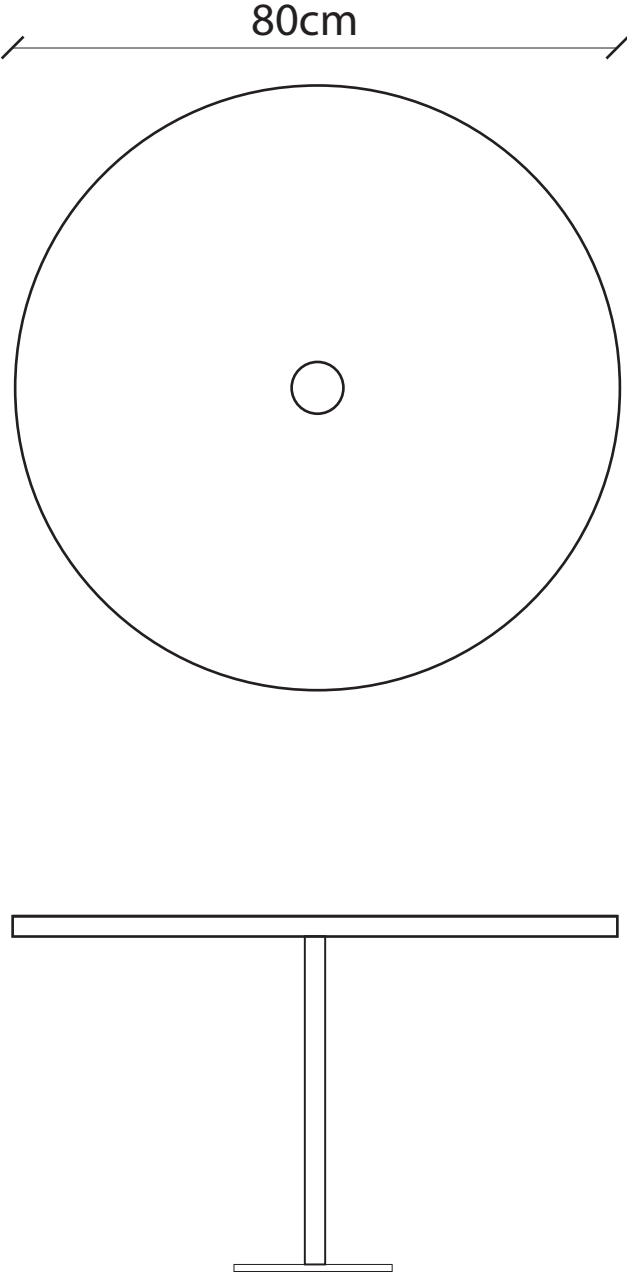

MC 1.51

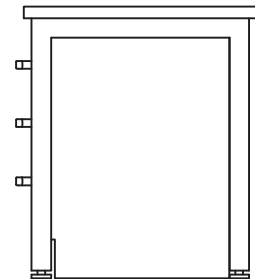
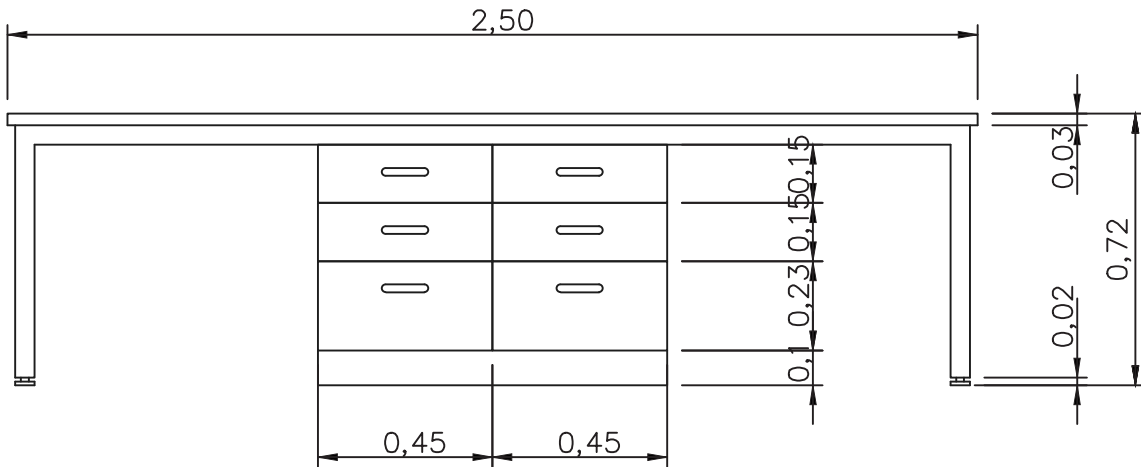
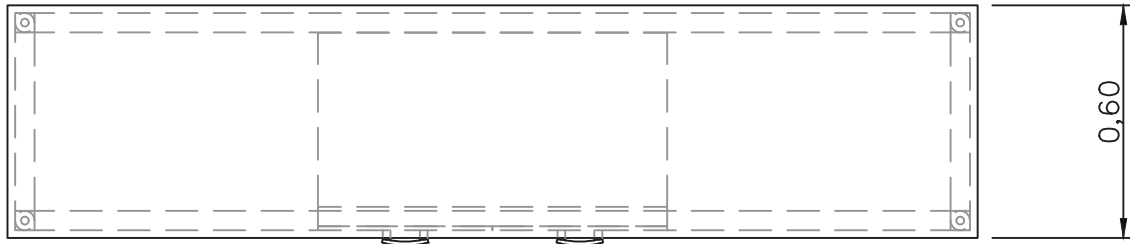
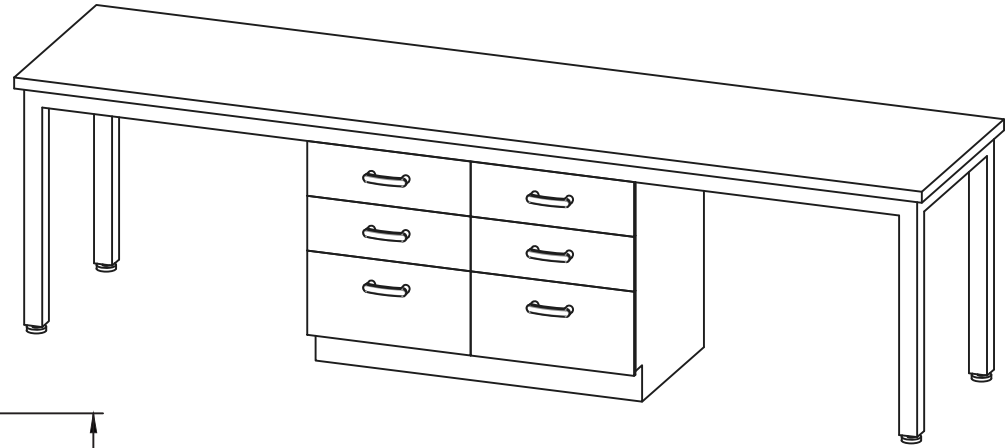

MC 1.52

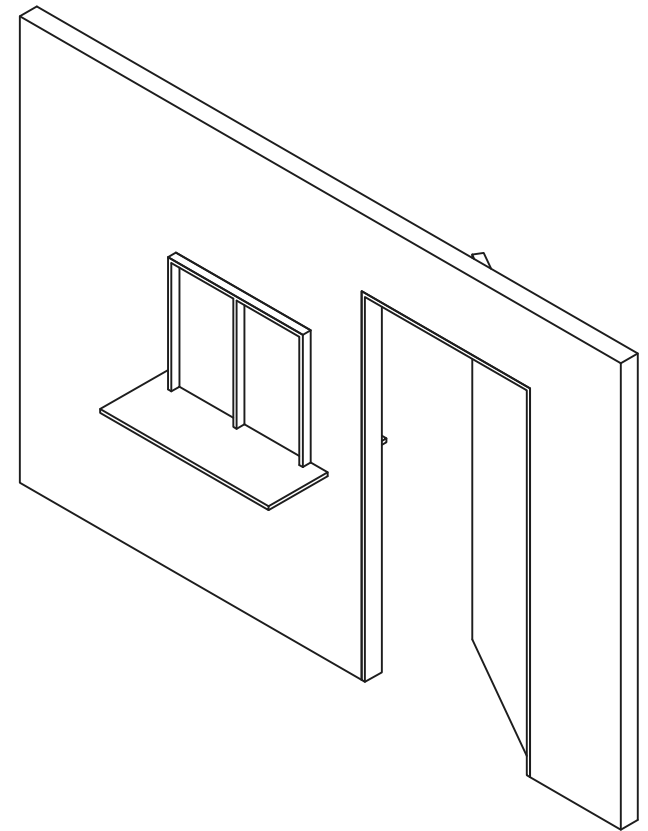
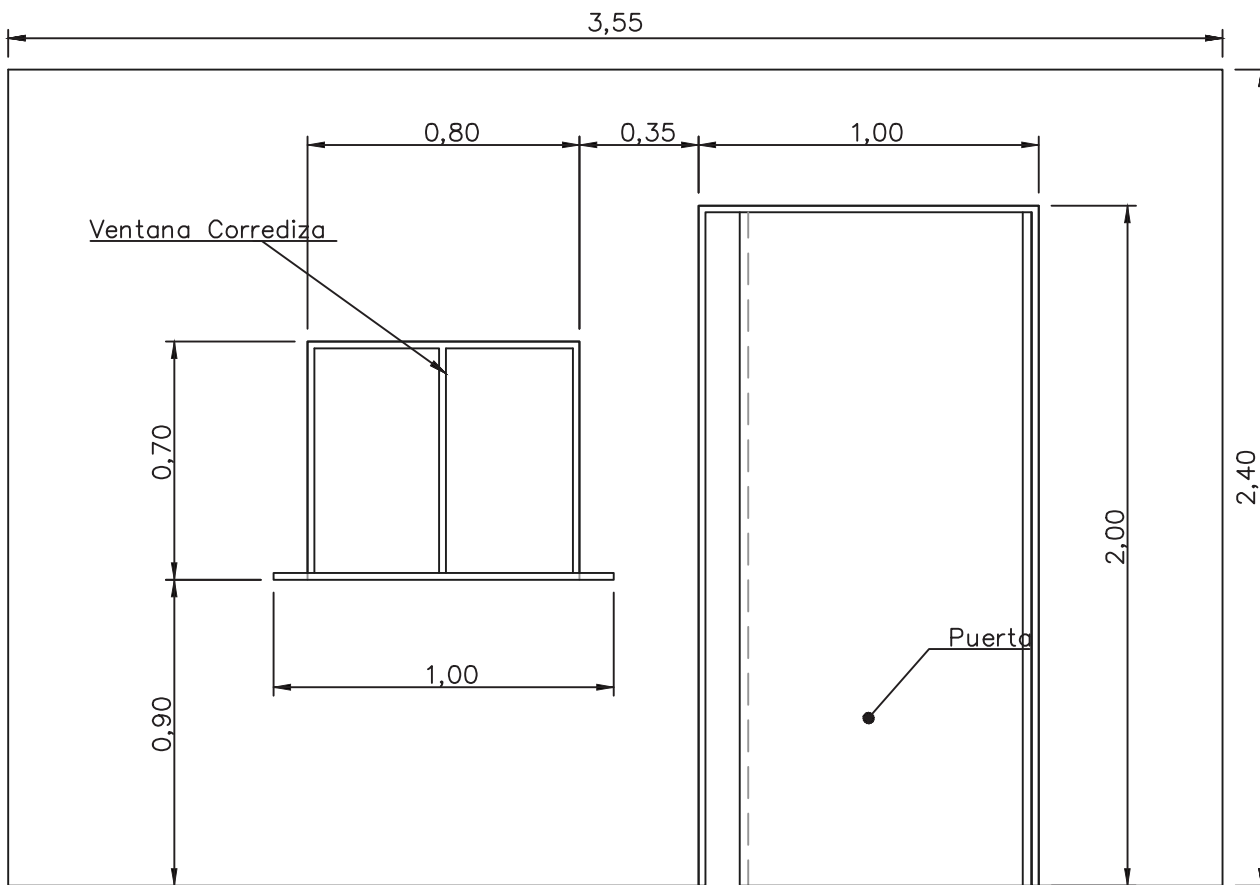
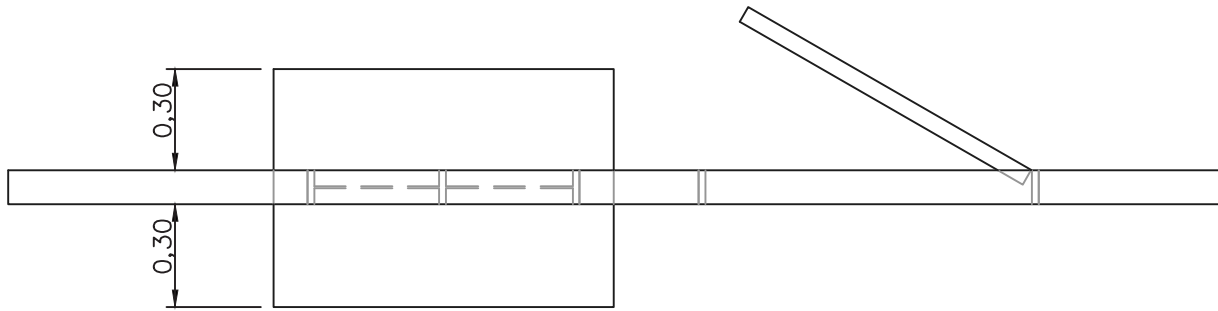

MC 1.53

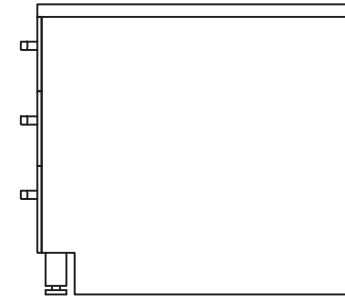
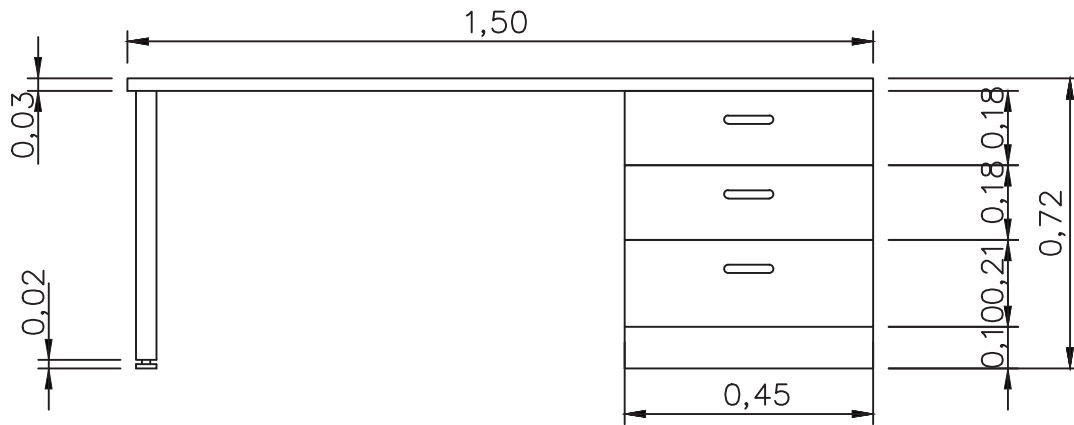
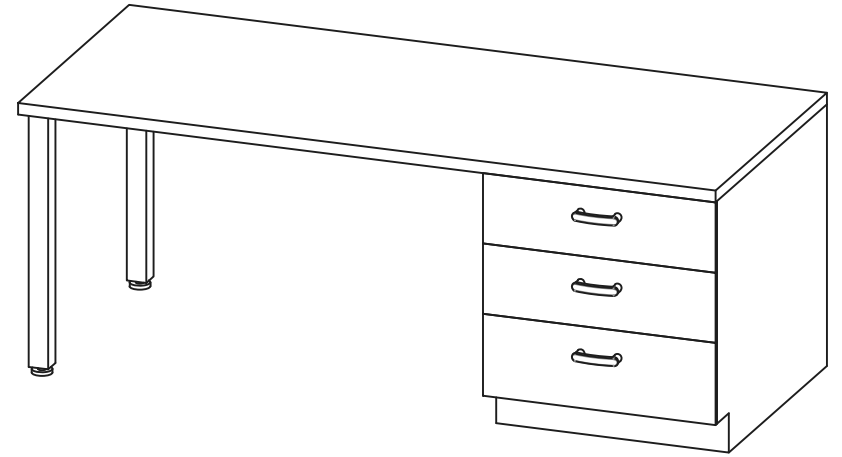
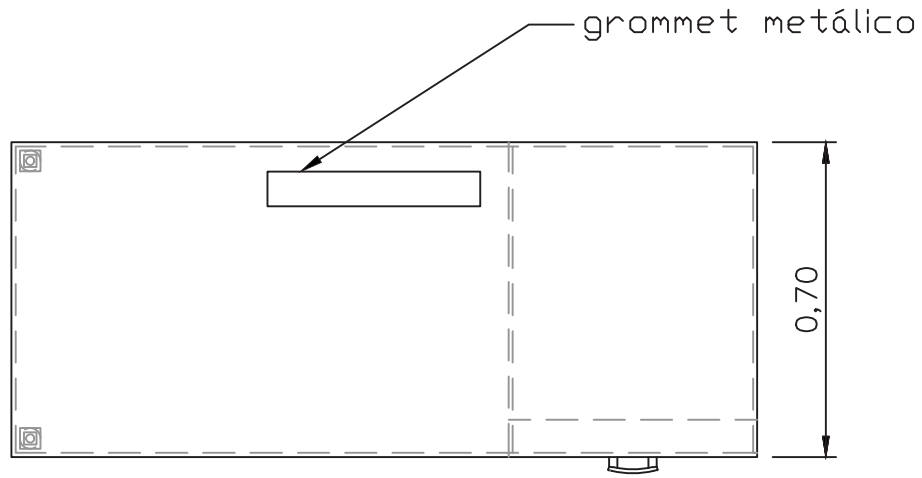

MC 1.54

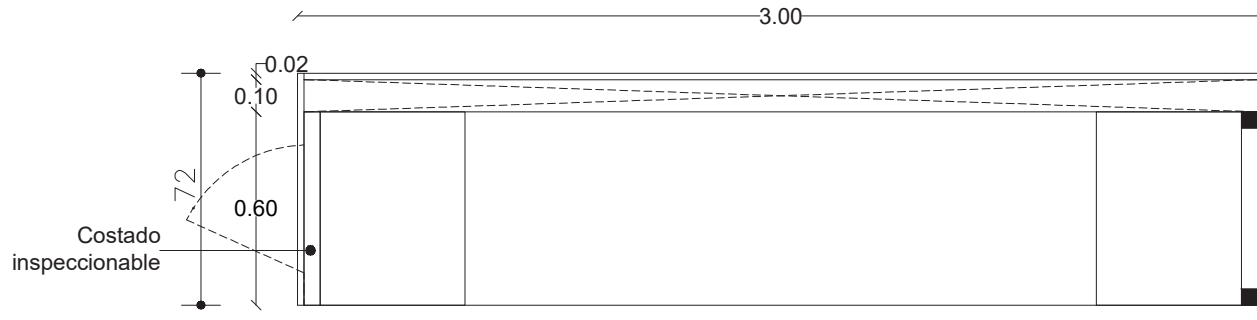

Planta

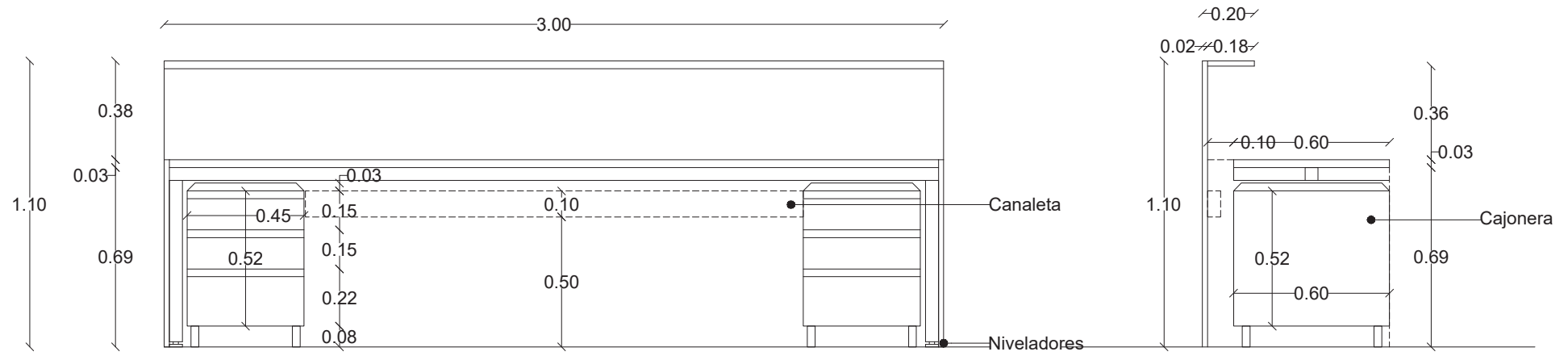

Alzado Frontal

Alzado lateral

MC 1.55

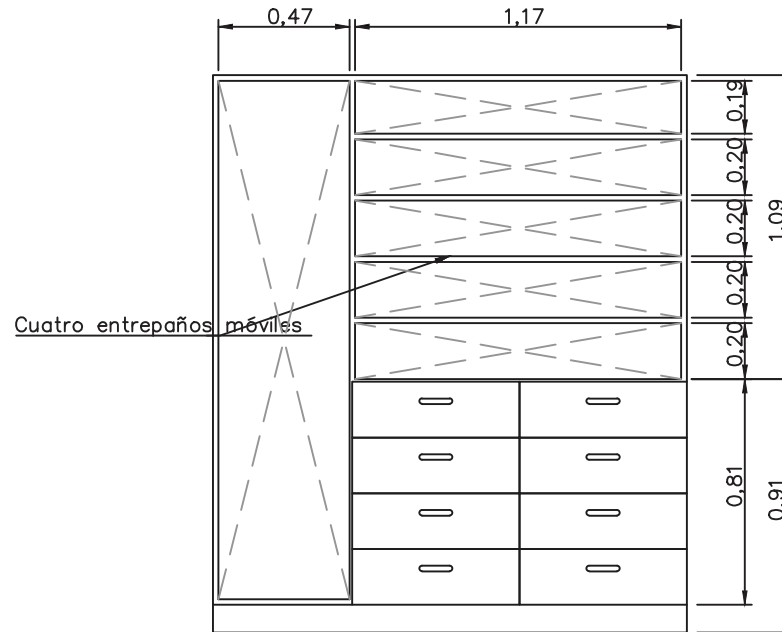
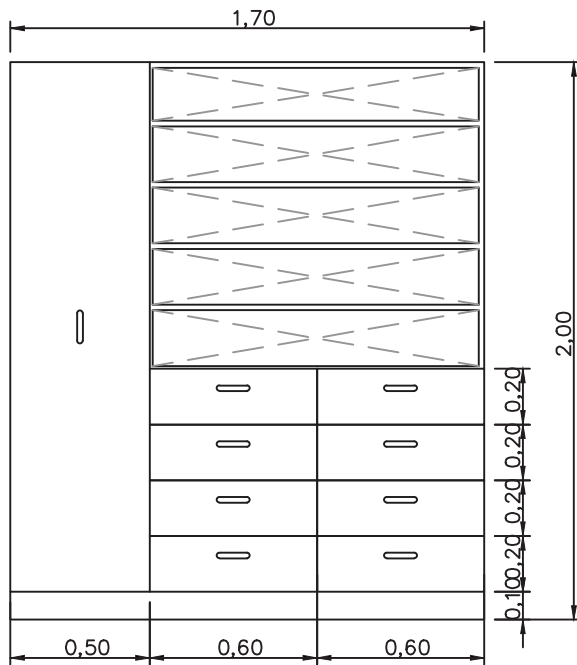
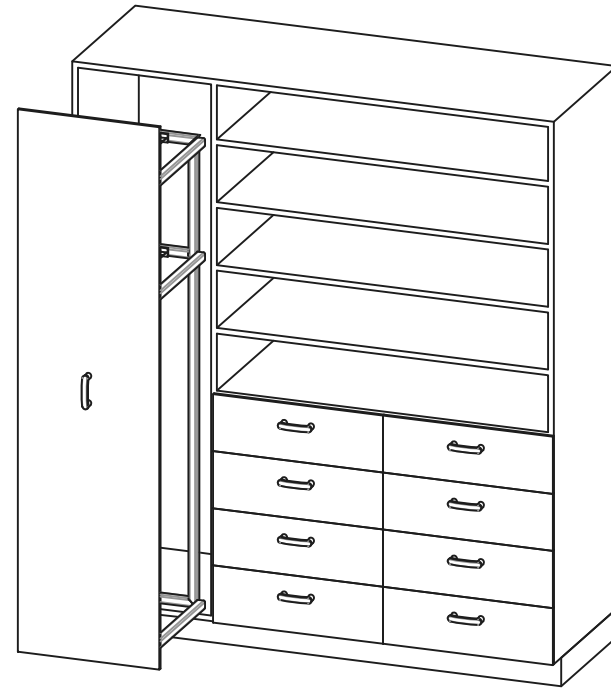
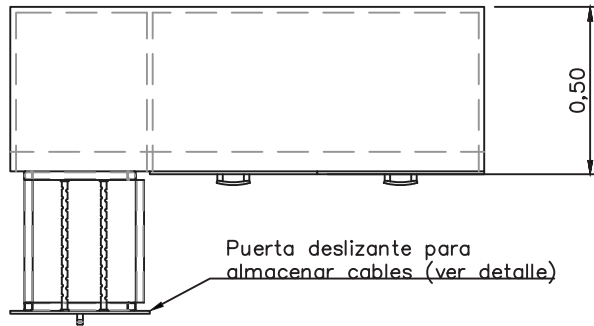

MC 1.56

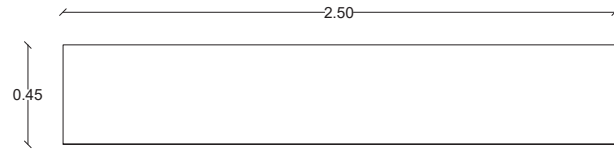

PLANTA

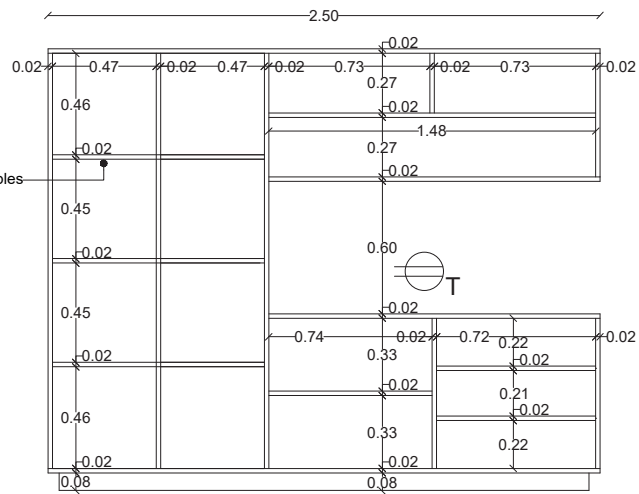

MUEBLE ABIERTO

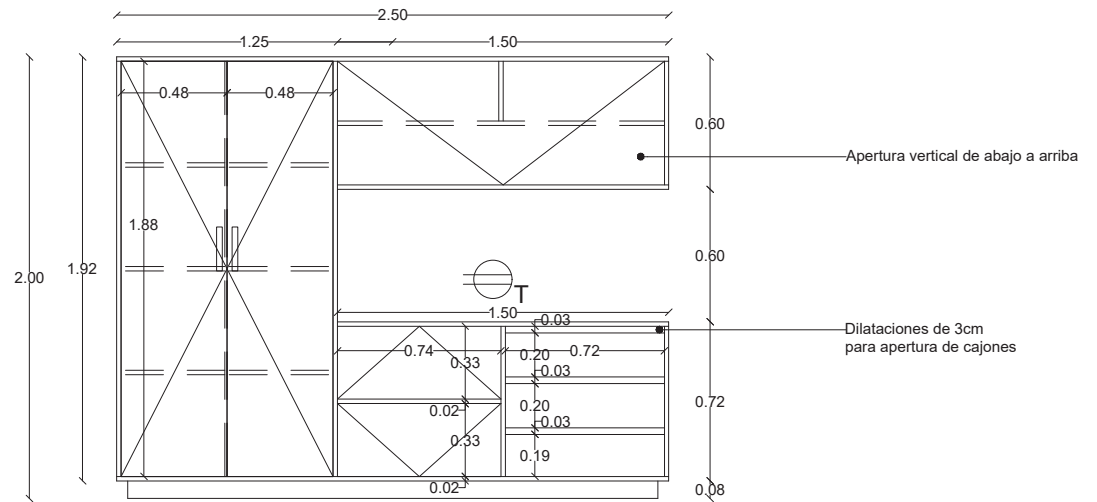

MUEBLE CERRADO

MC 1.57

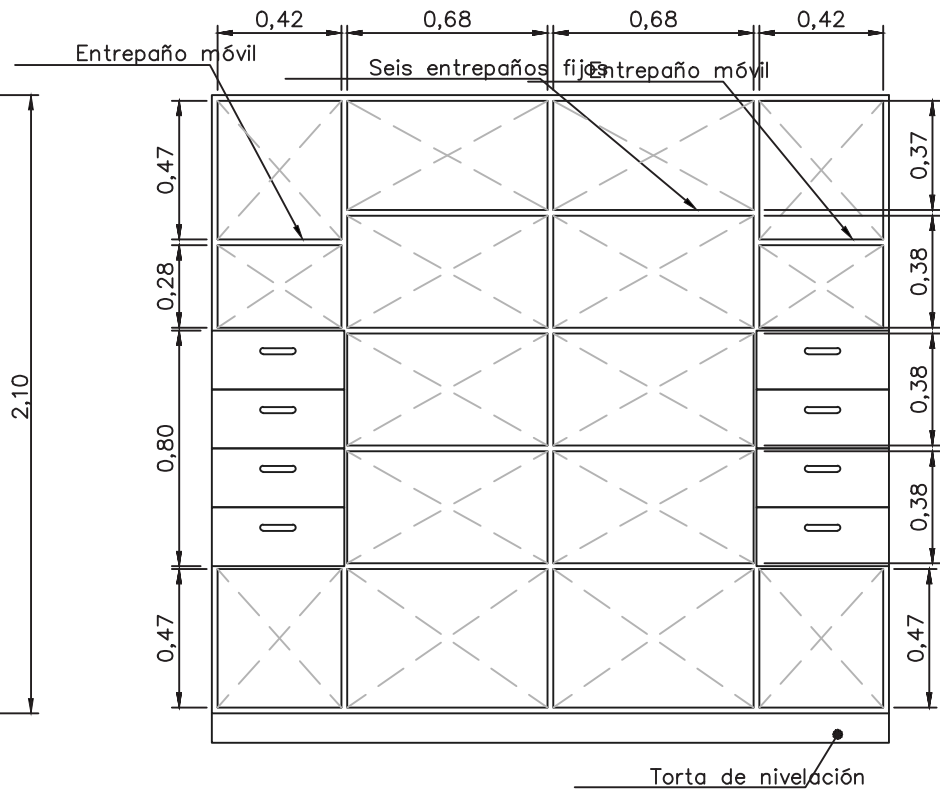
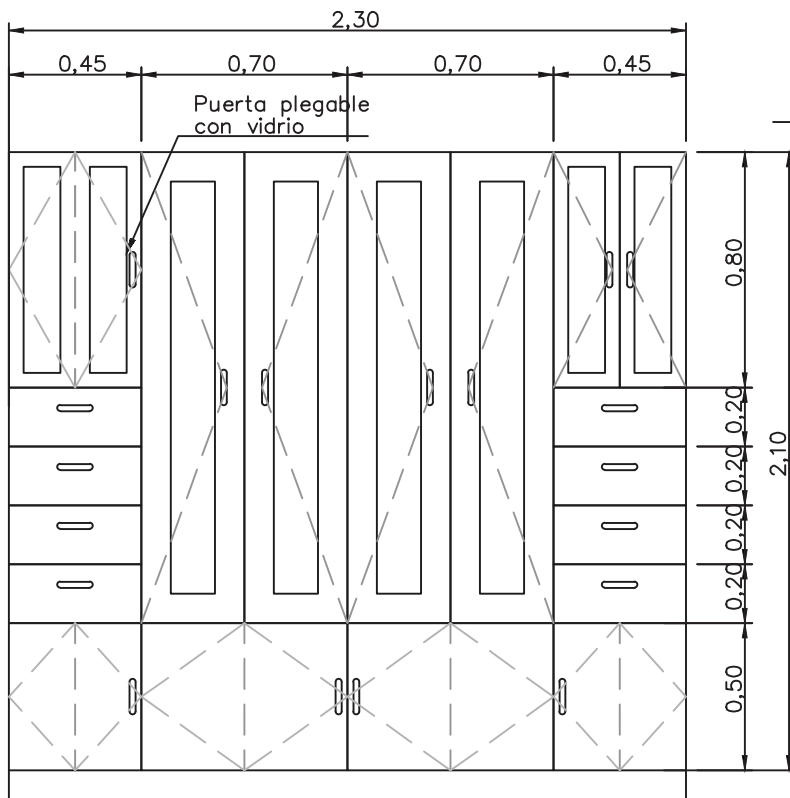
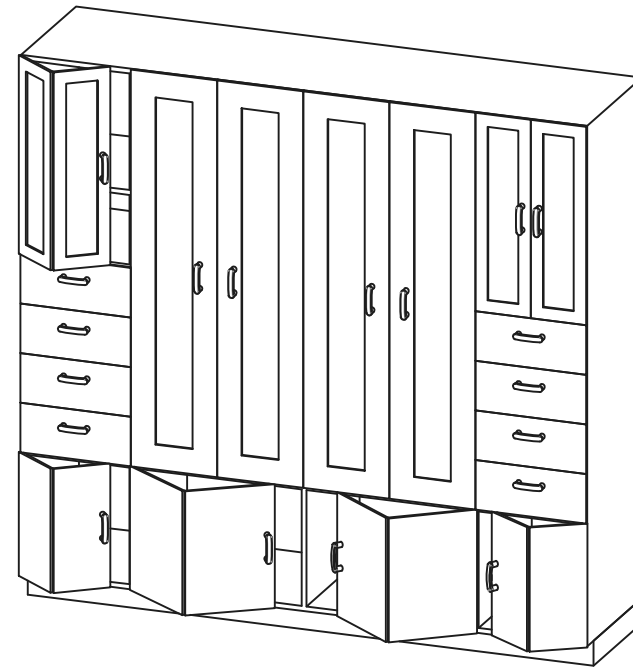
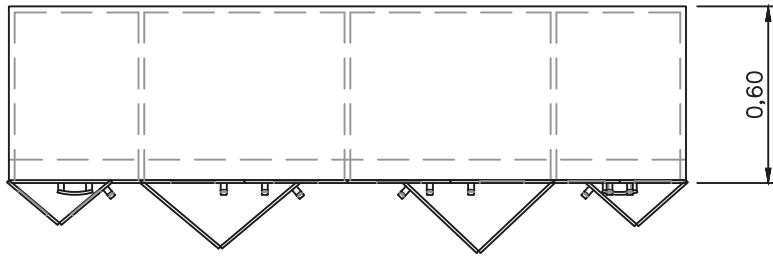

MC 1.58

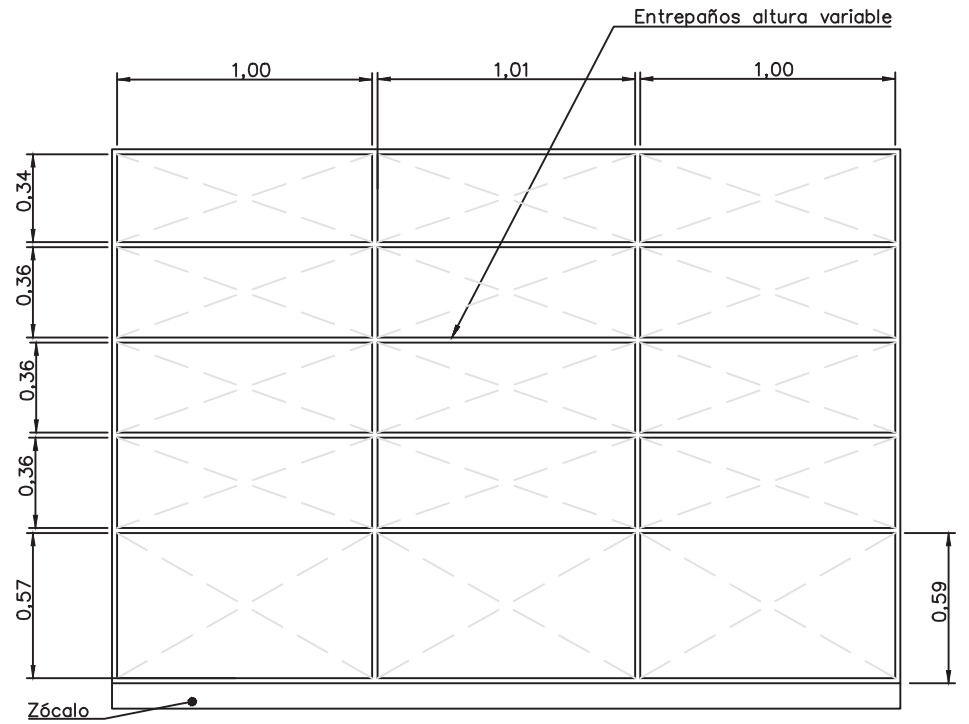
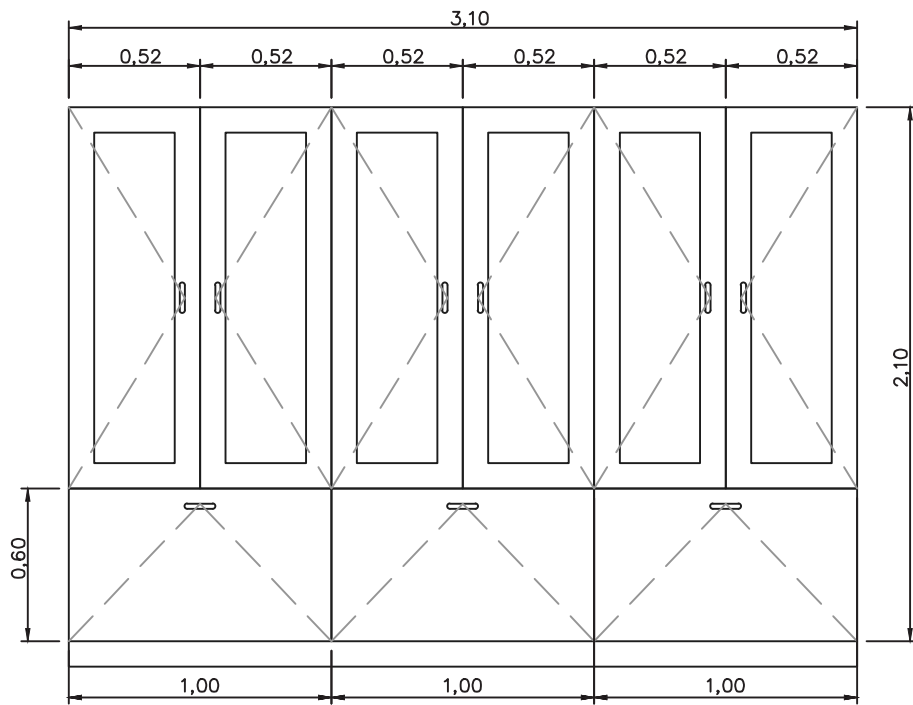
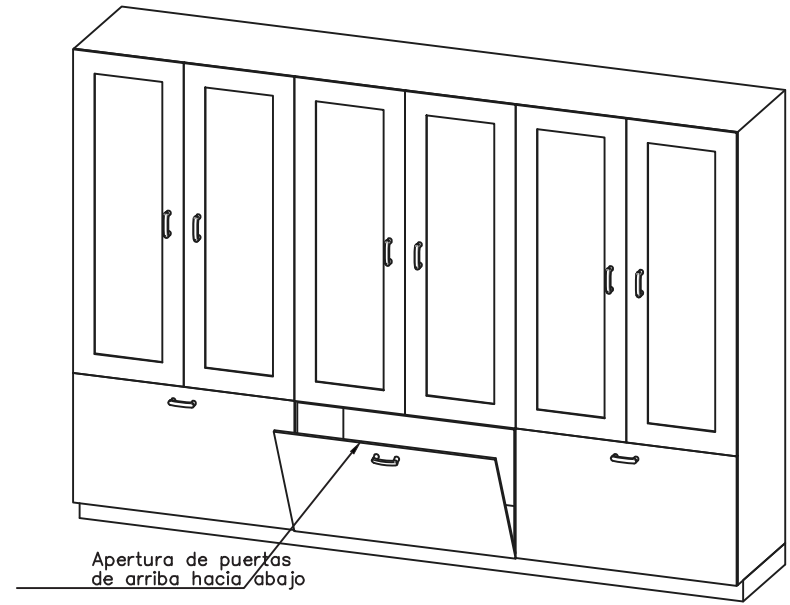
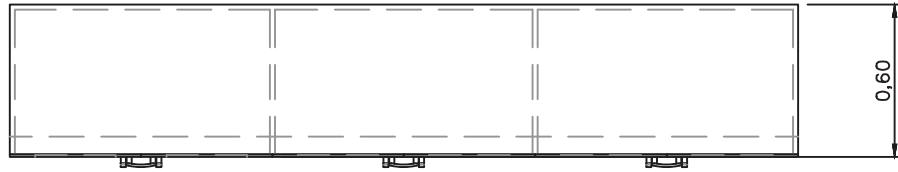

MC 1.59

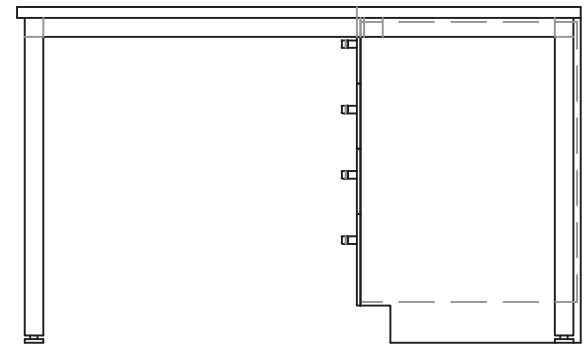
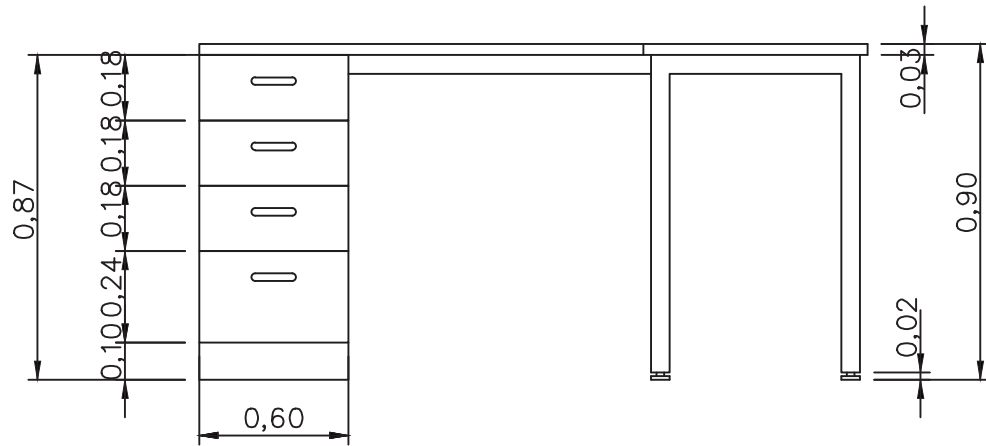
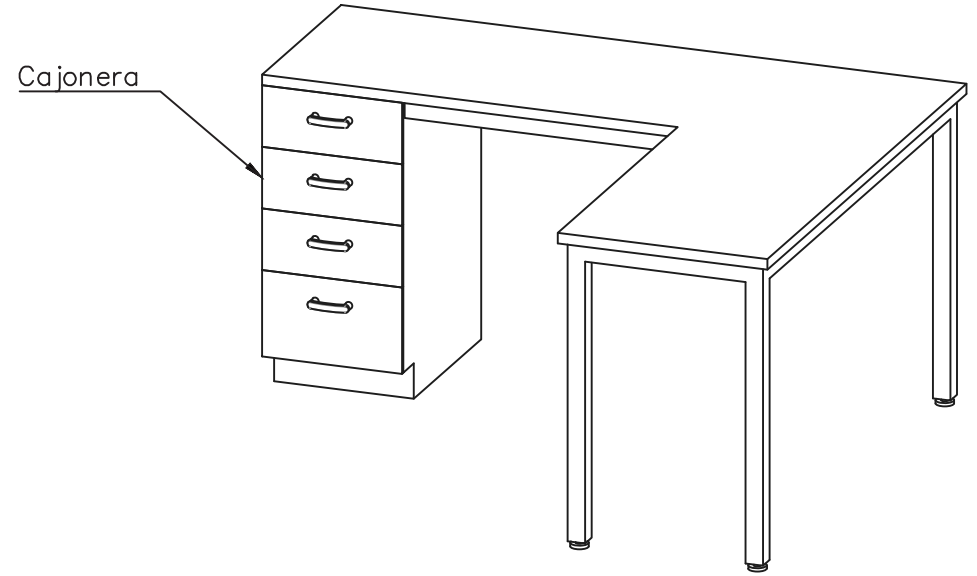
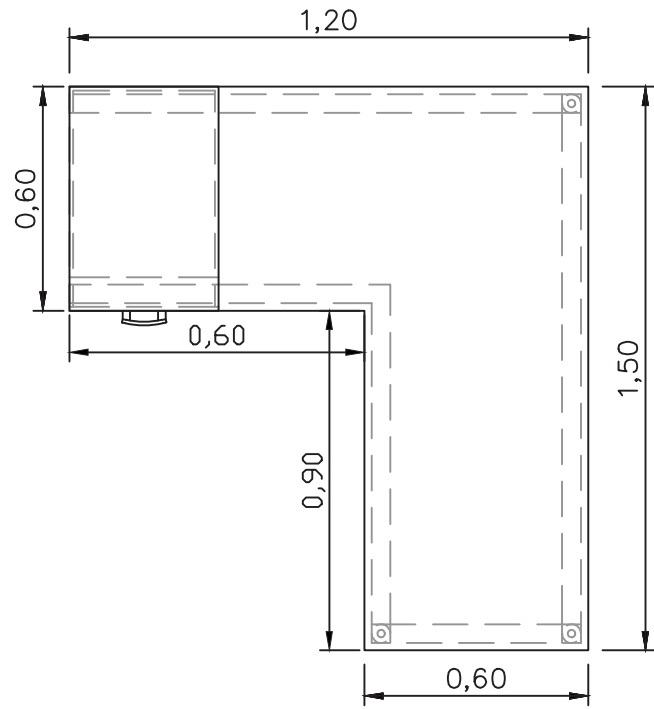

MC 1.60

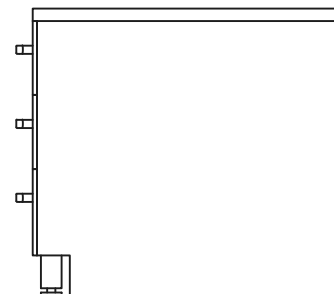
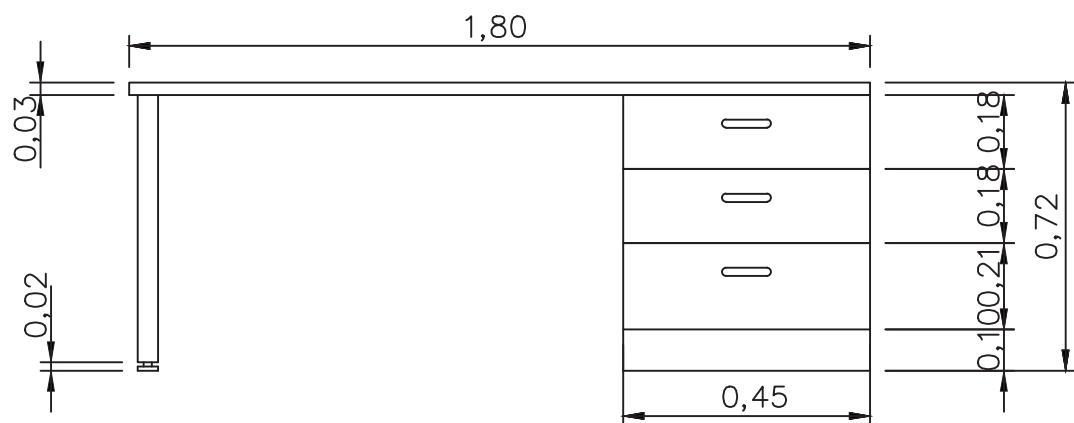
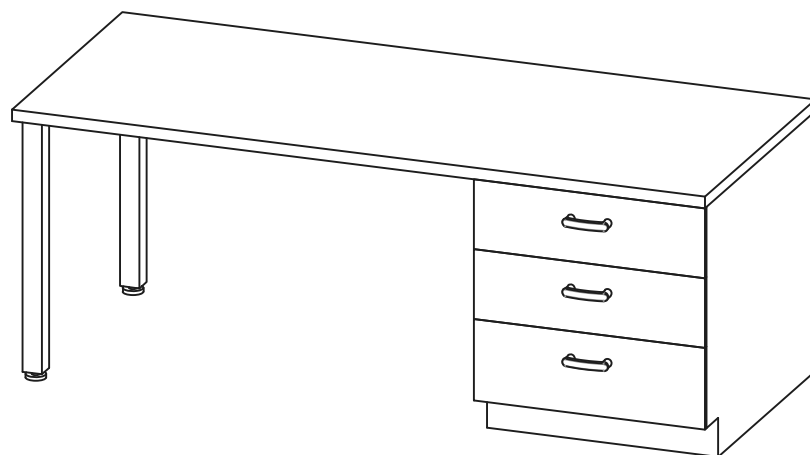
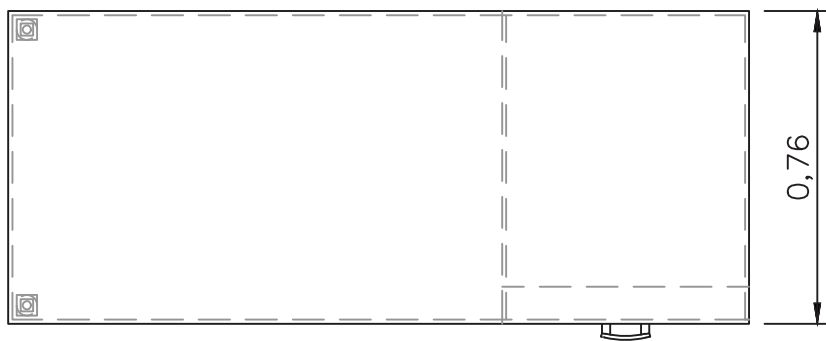

MC 1.61

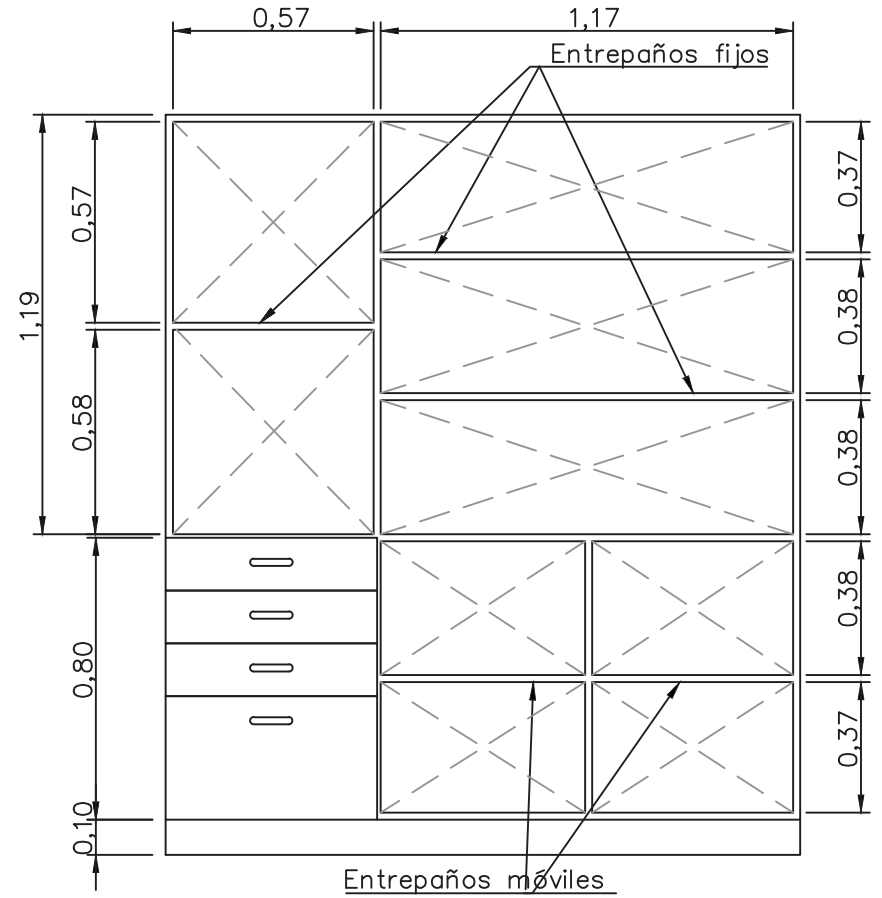
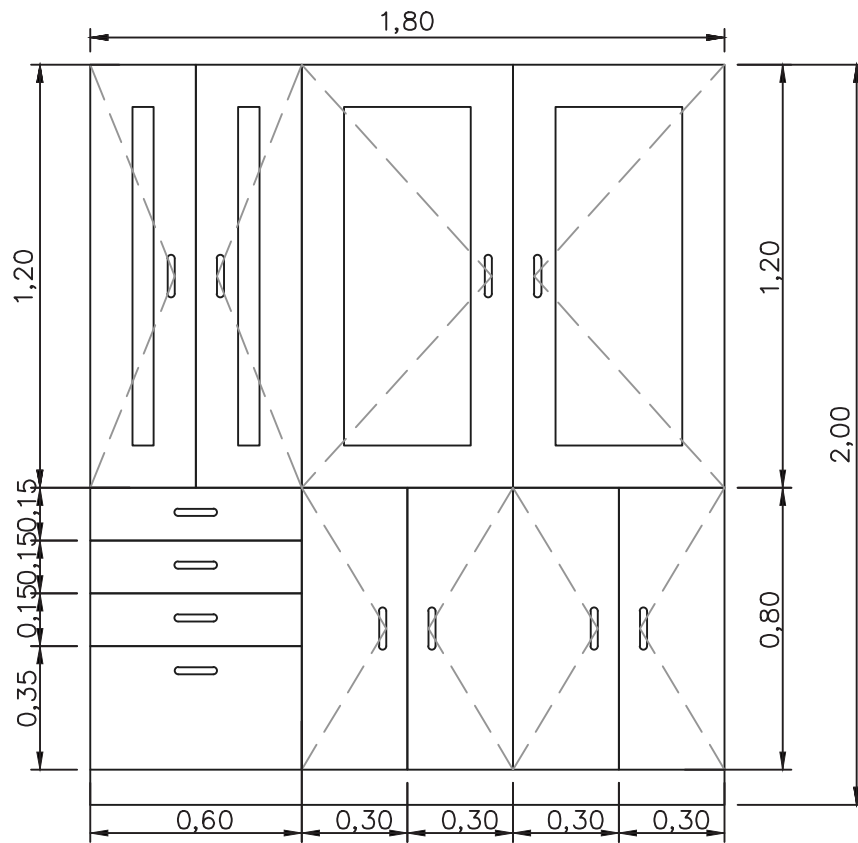
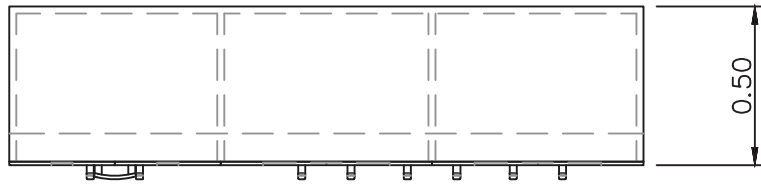

MC 1.62

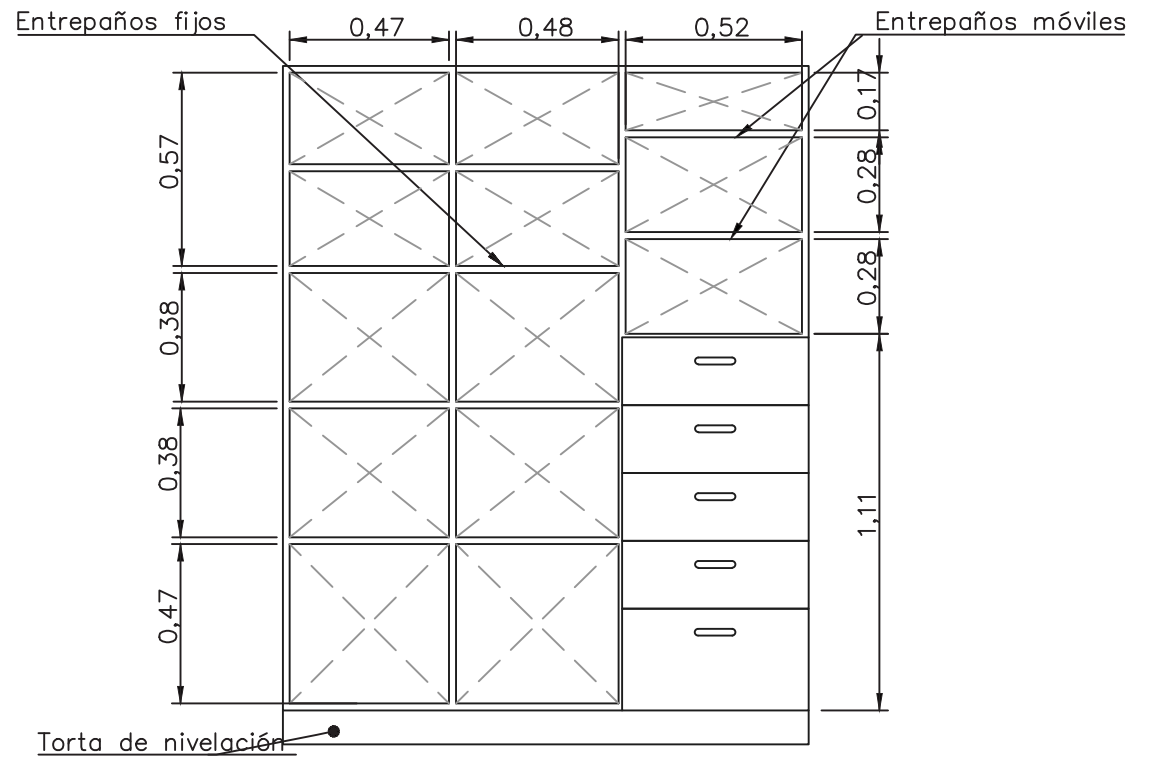
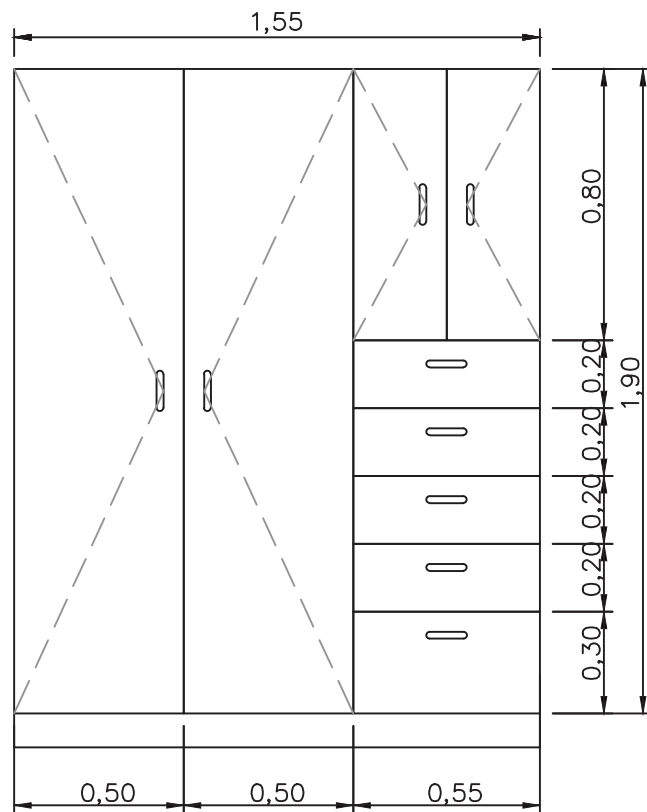
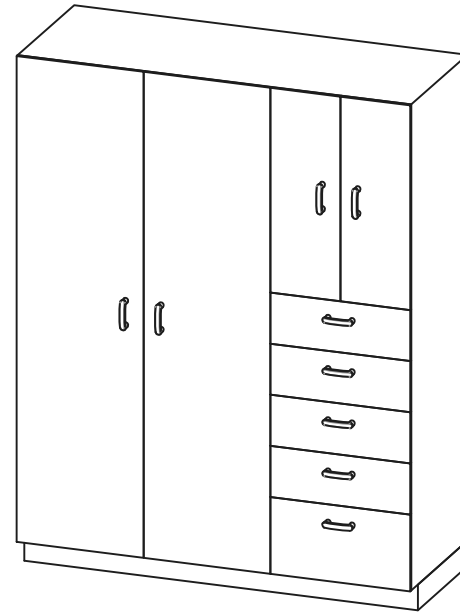
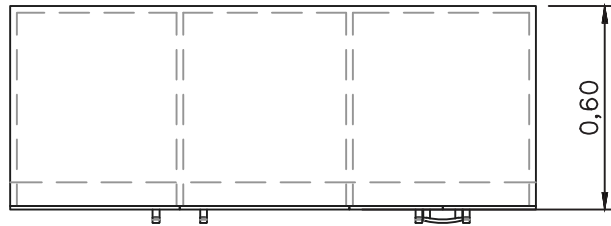

MC 1.63

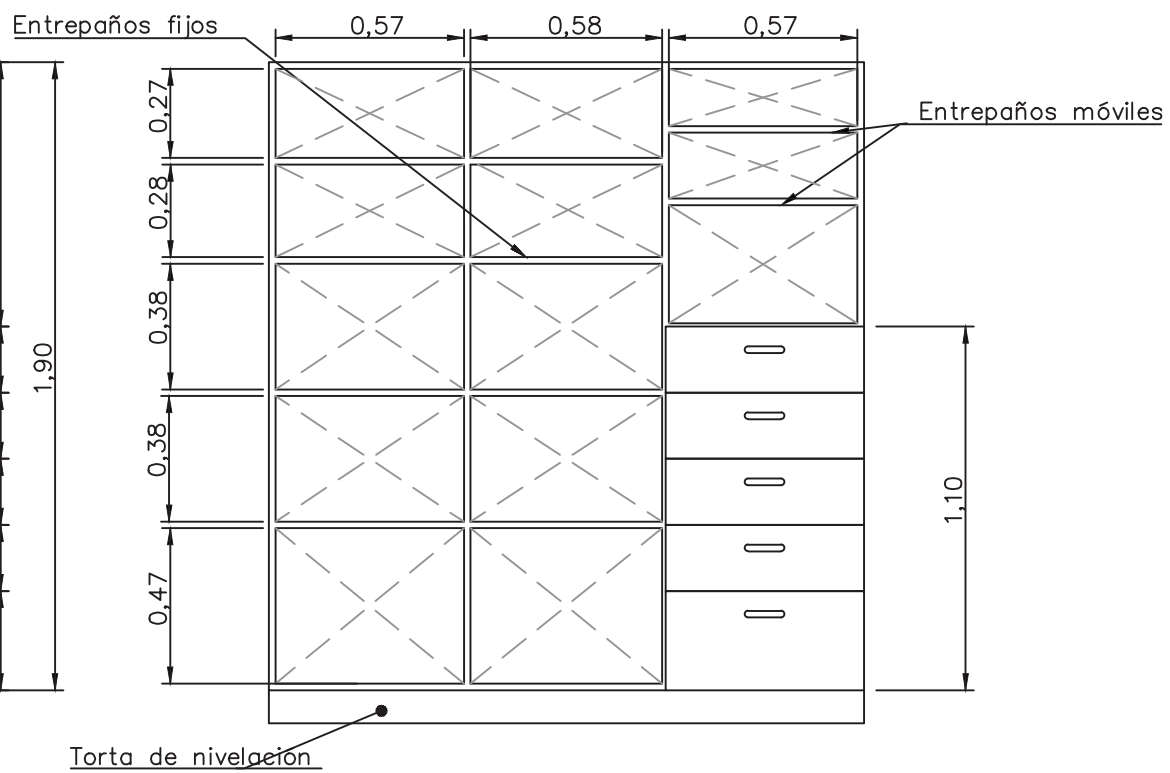
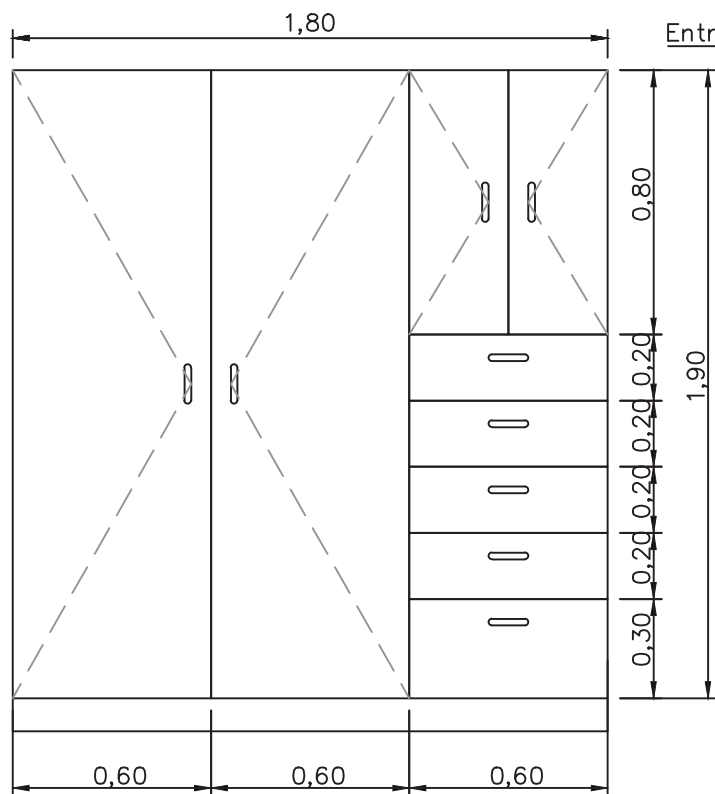
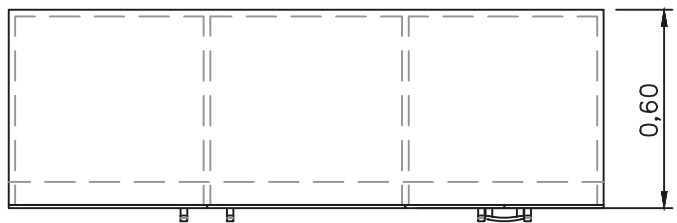

MC 1.64

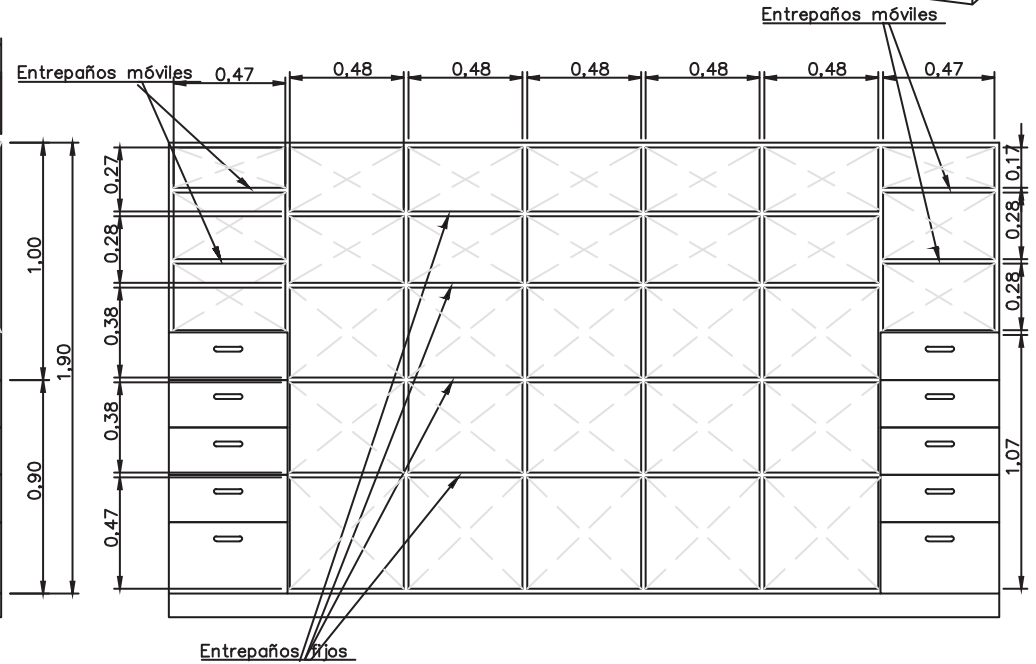
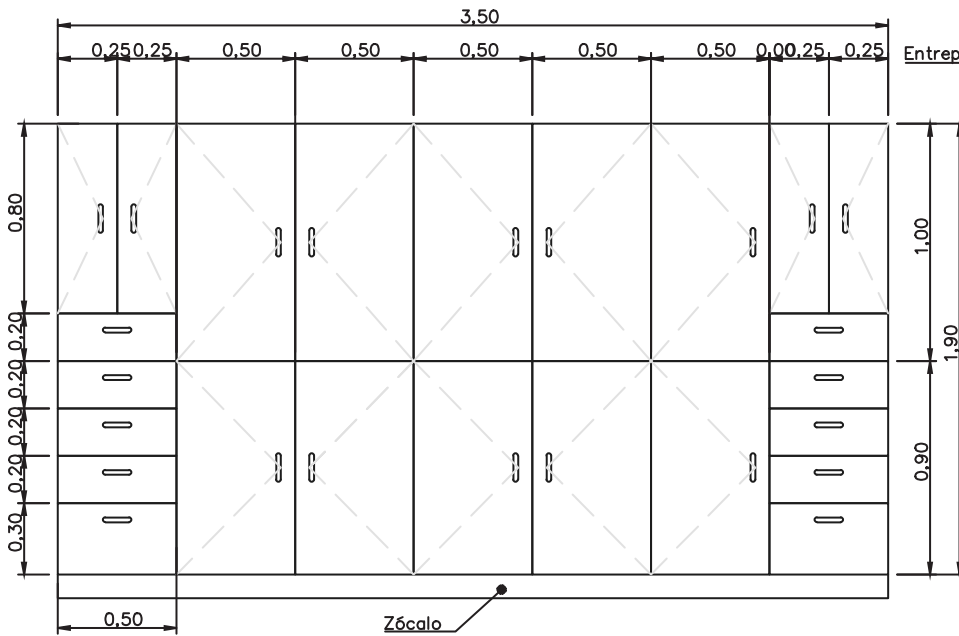
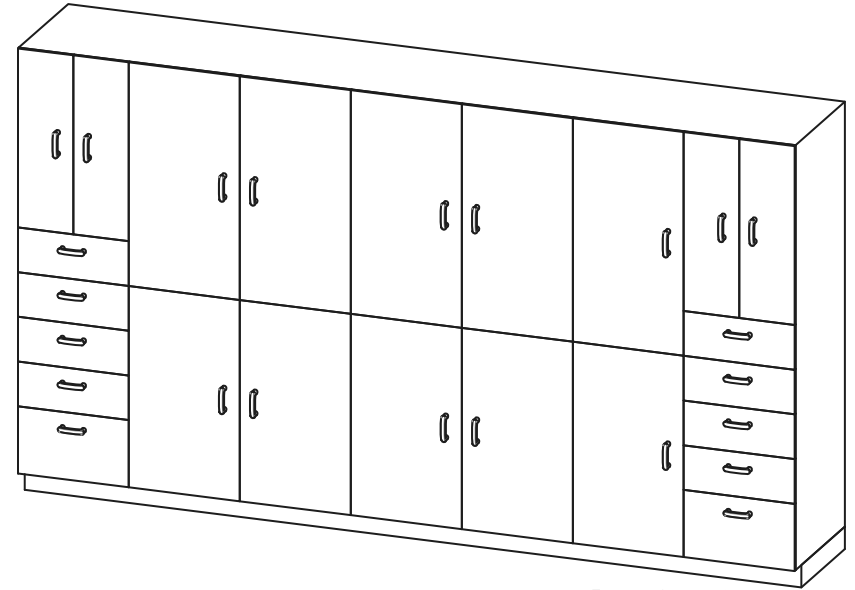
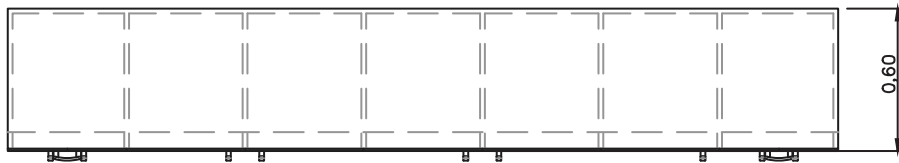

MC 1.65

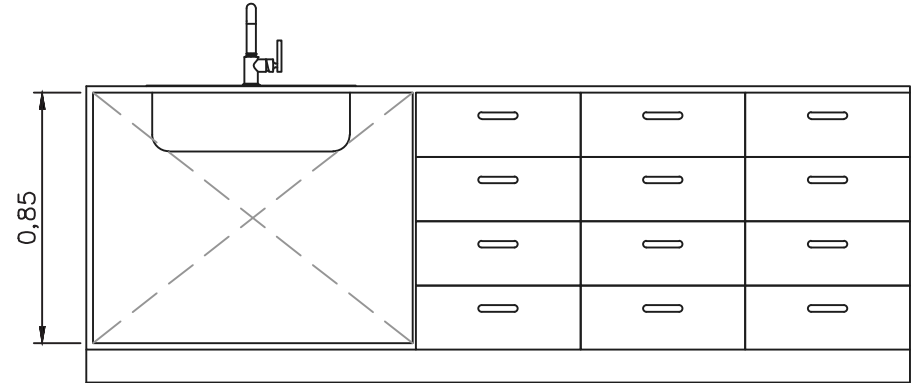
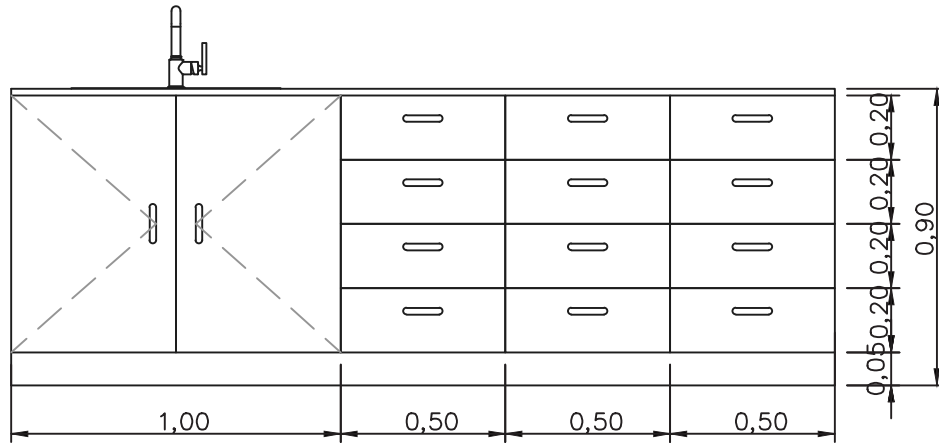
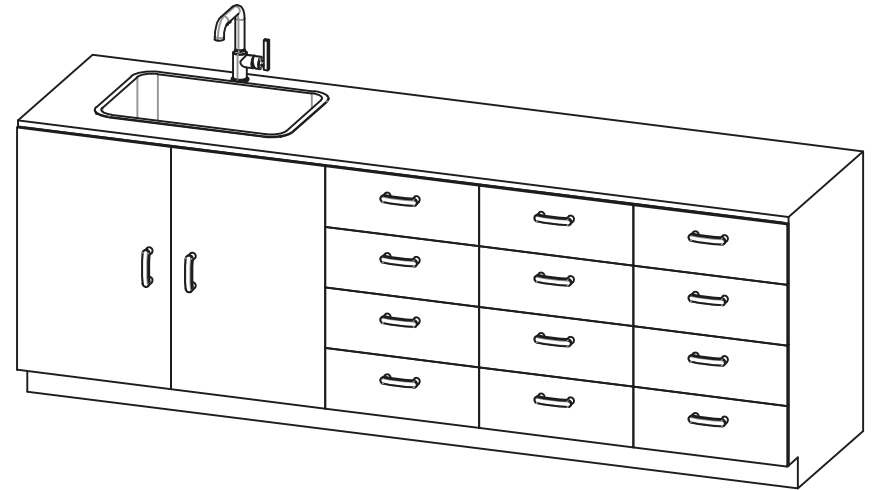
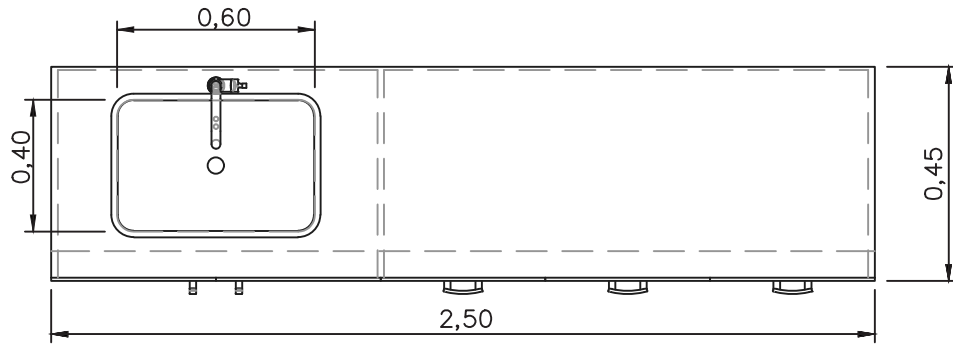

MC 1.66

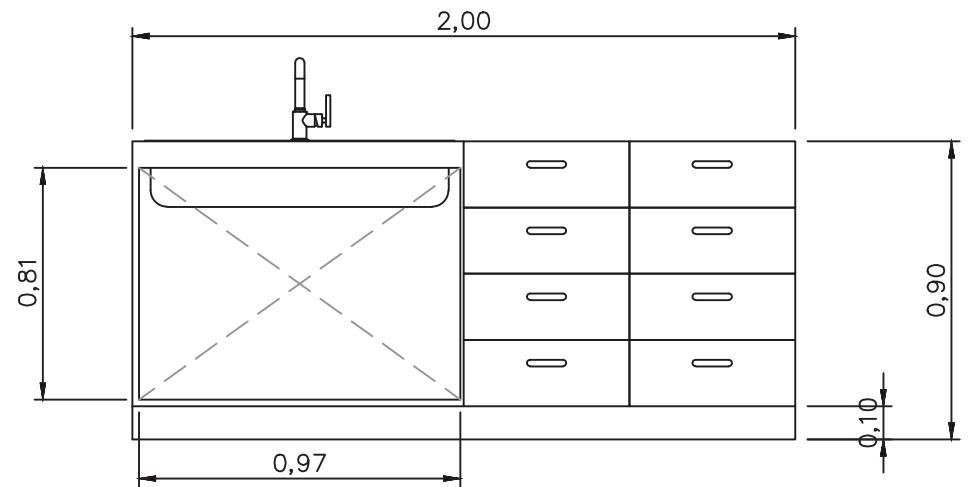
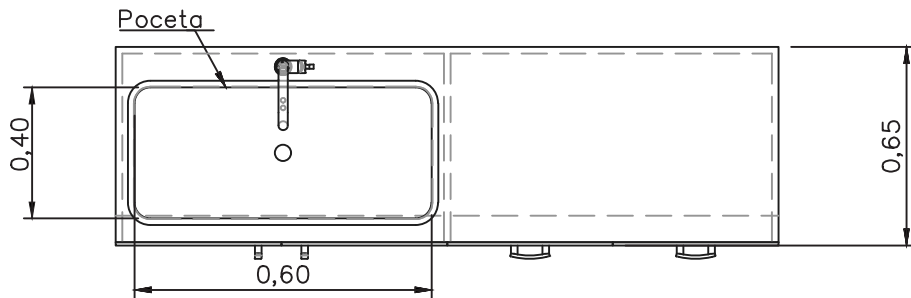
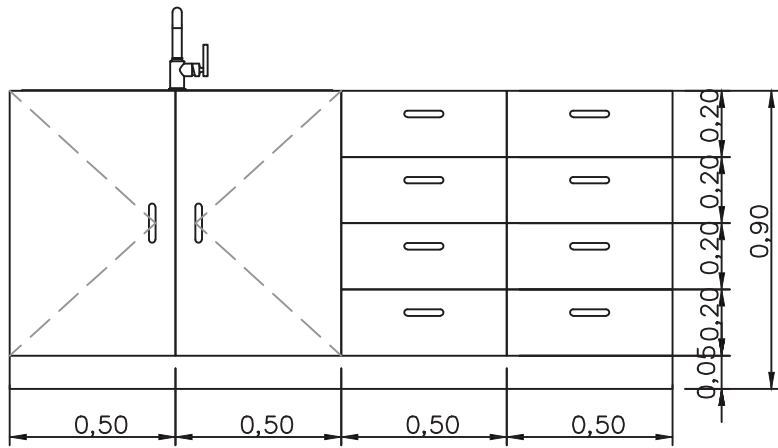

MC 1.67

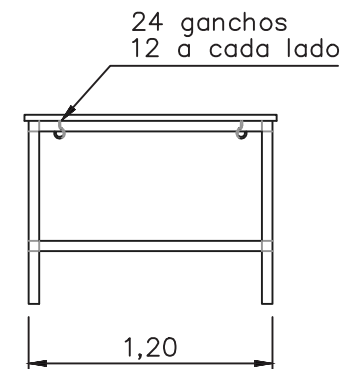
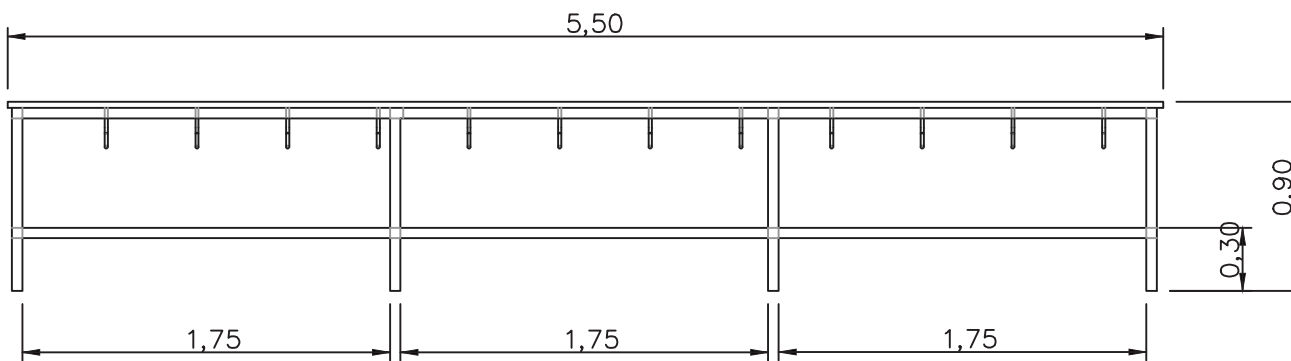
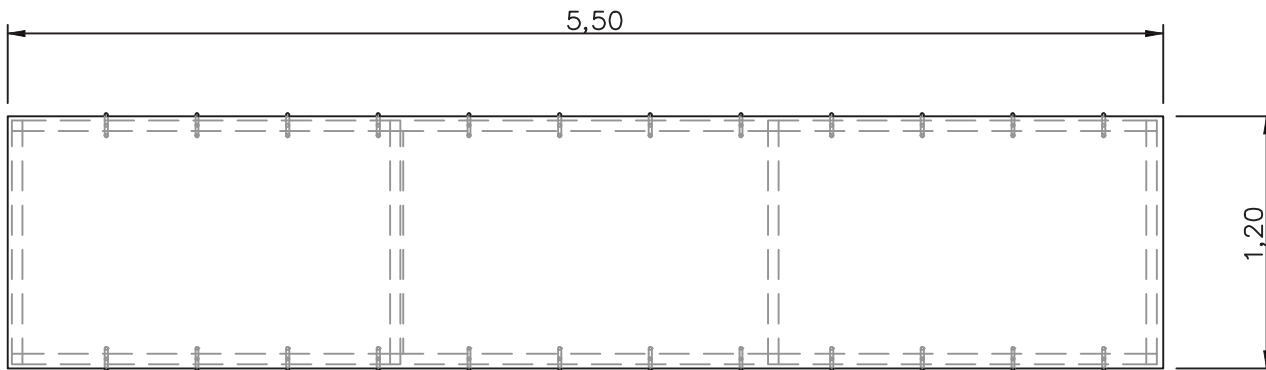
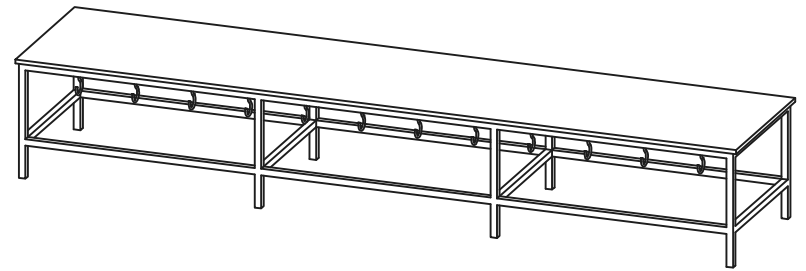

MC 1.68

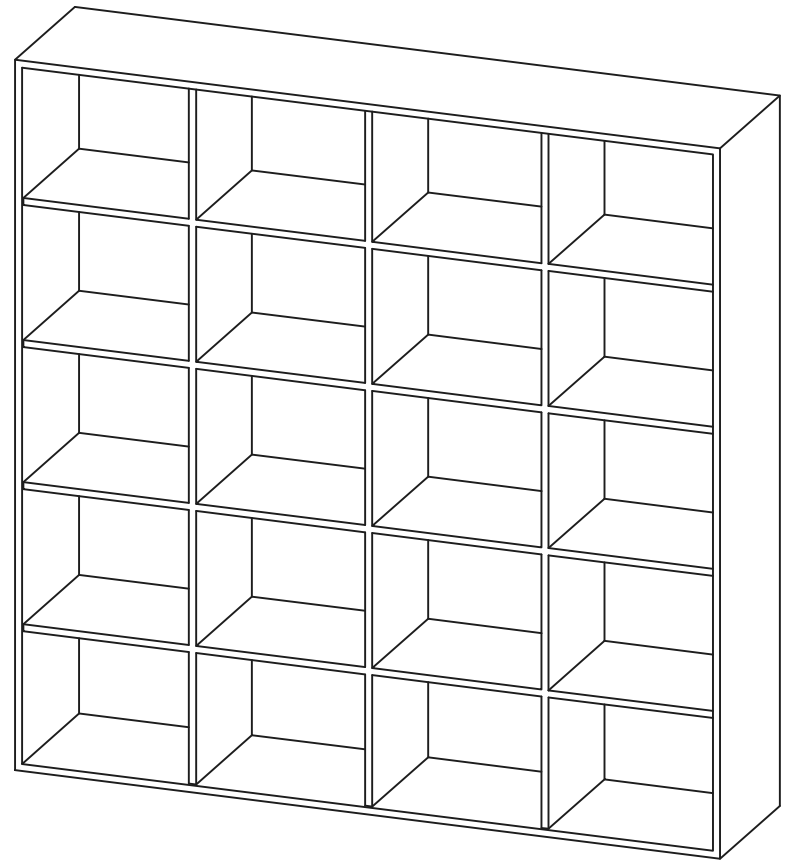
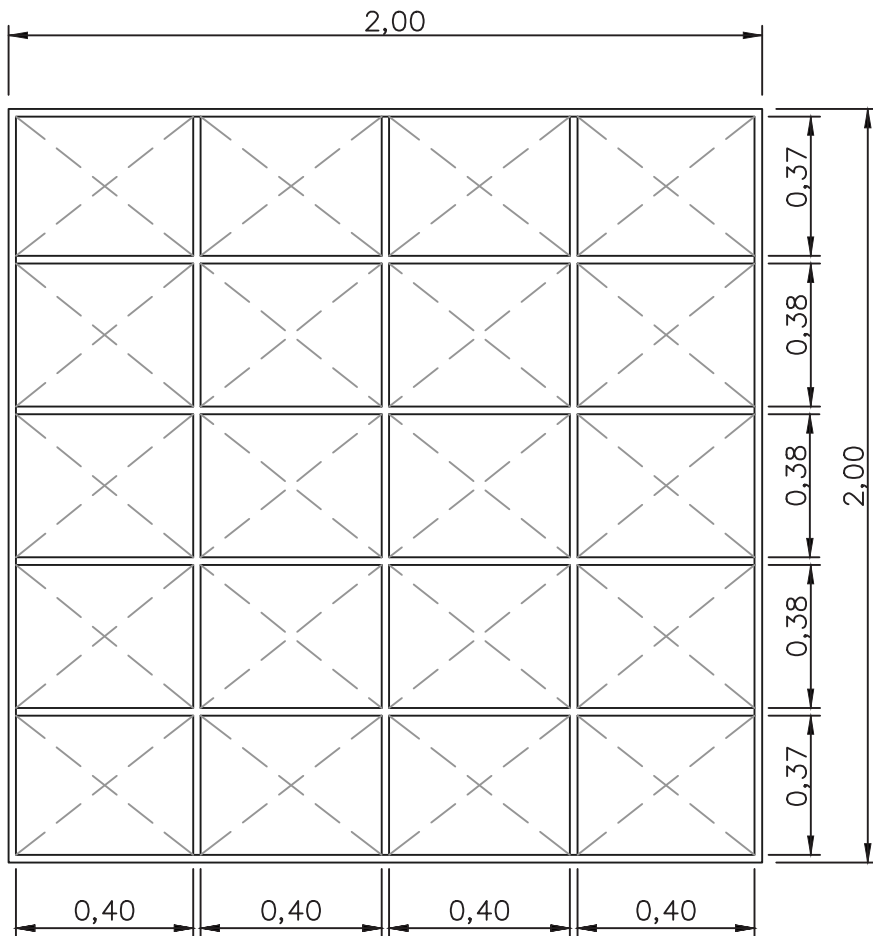
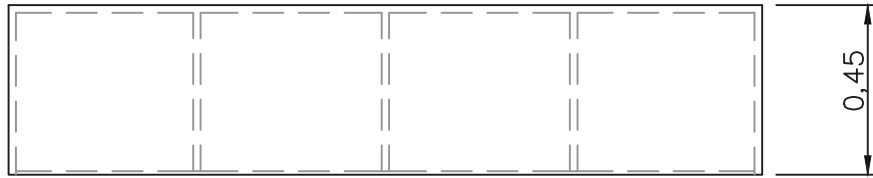

MC 1.69

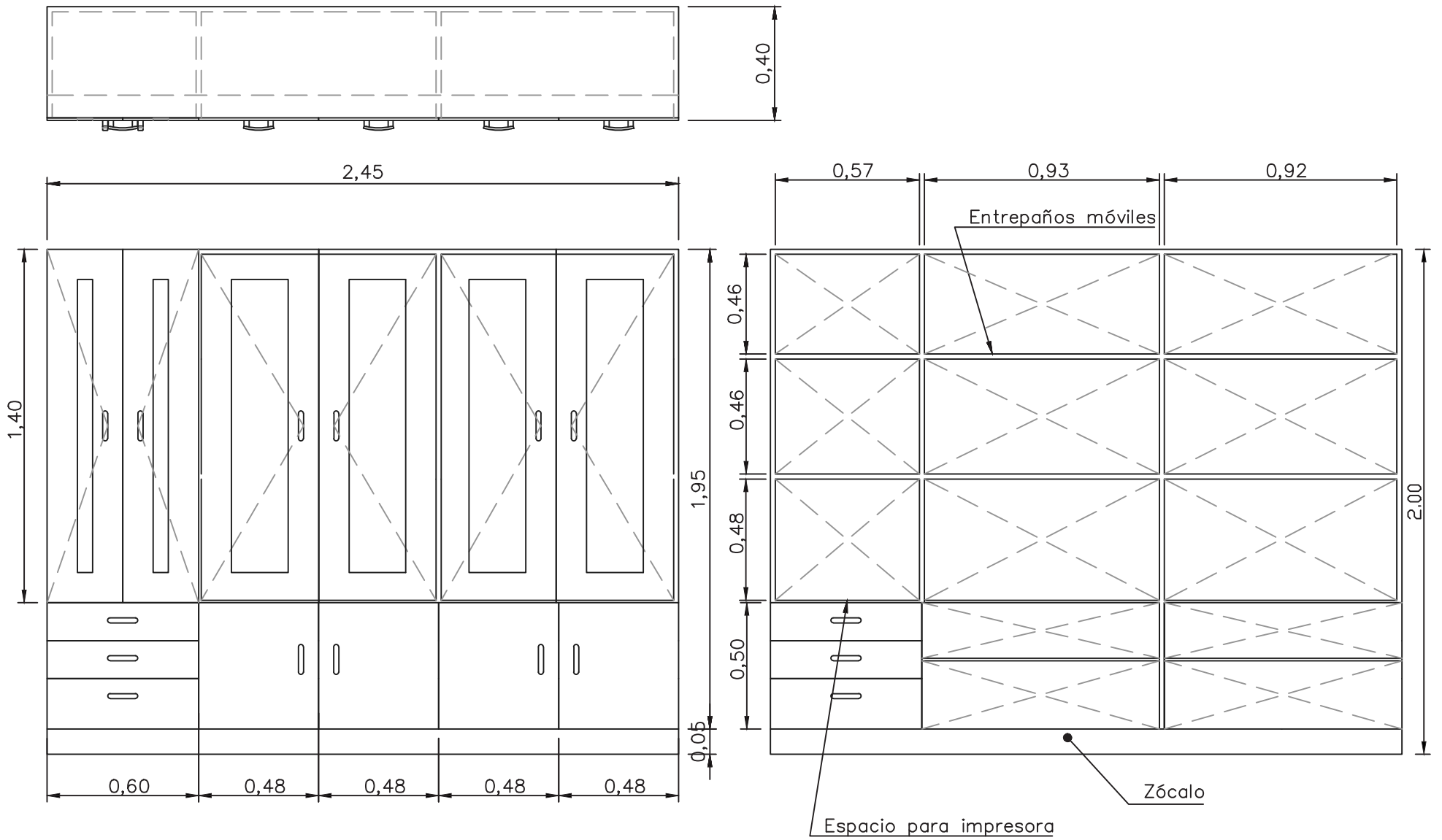

MC 1.70

SOLO DESCRIPCIÓN TÉCNICA

MC 1.71

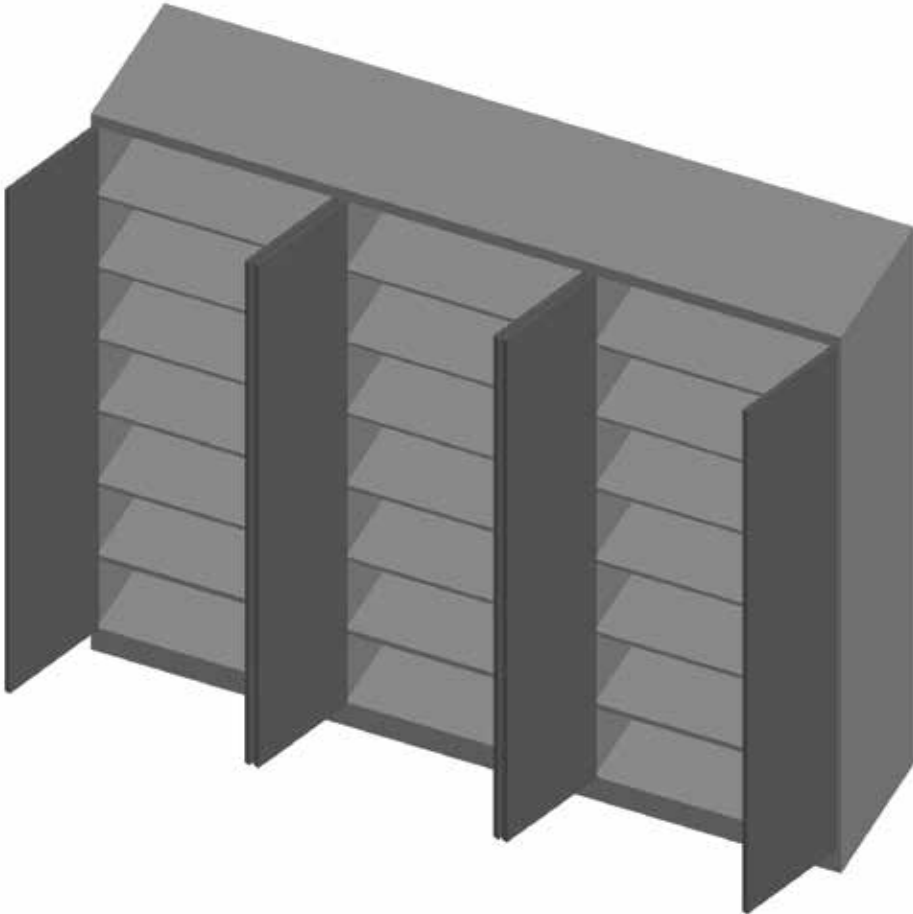

MC 1.72

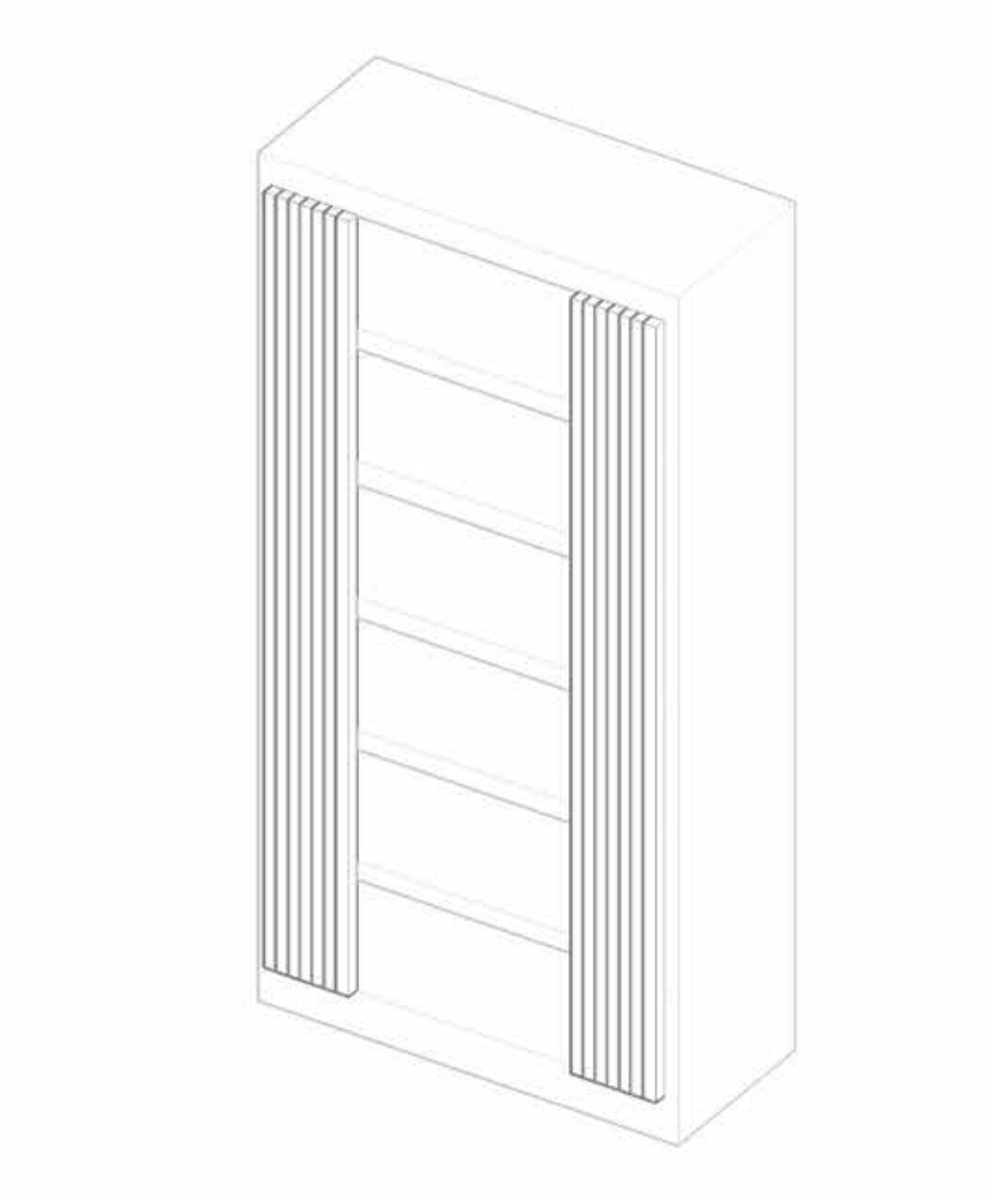

MC 1.73

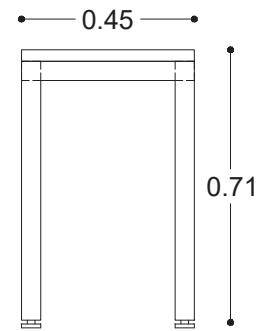
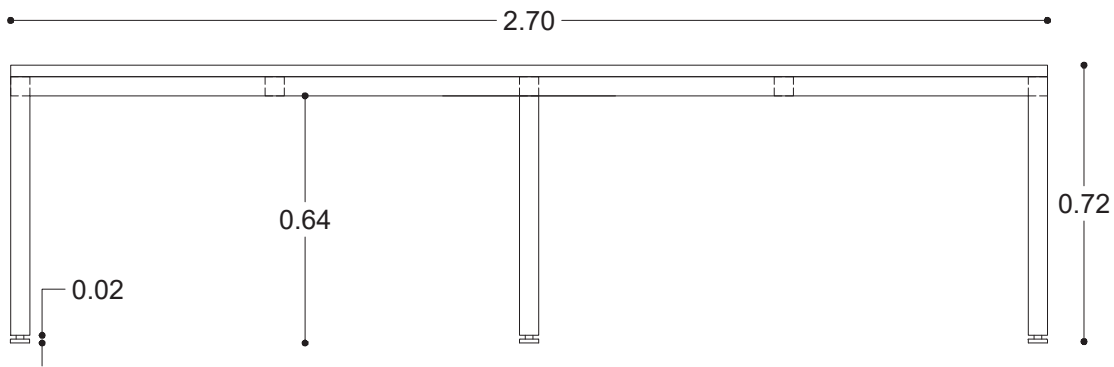
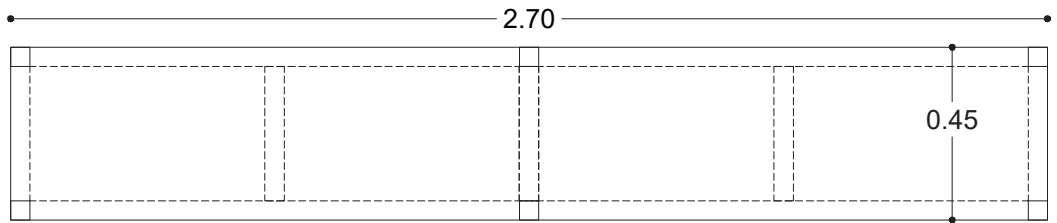

MC 1.74

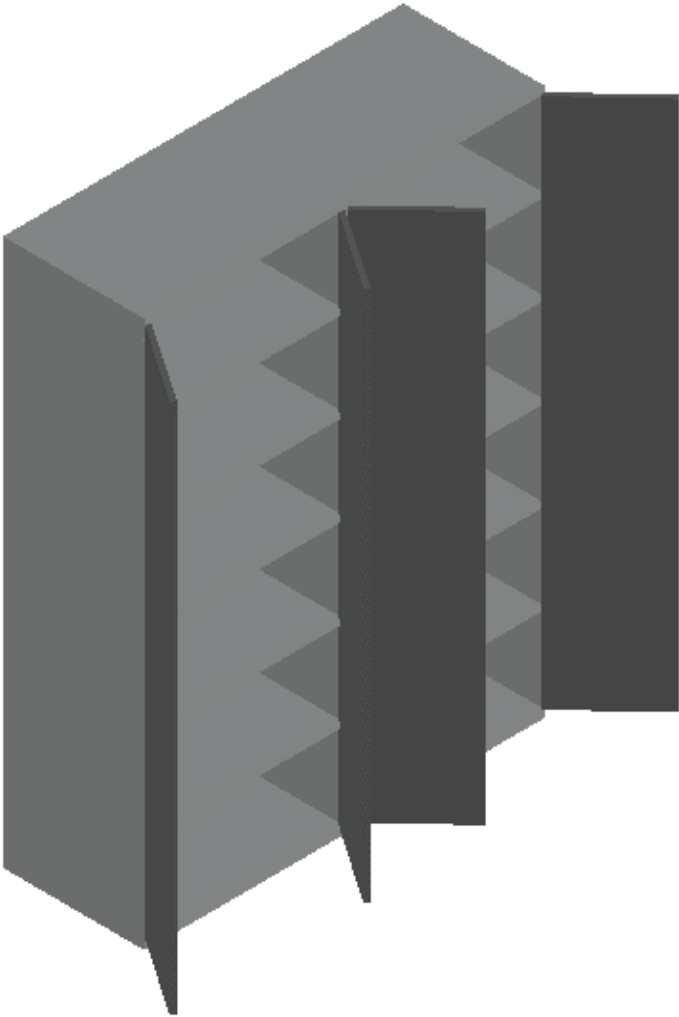

MC 1.75

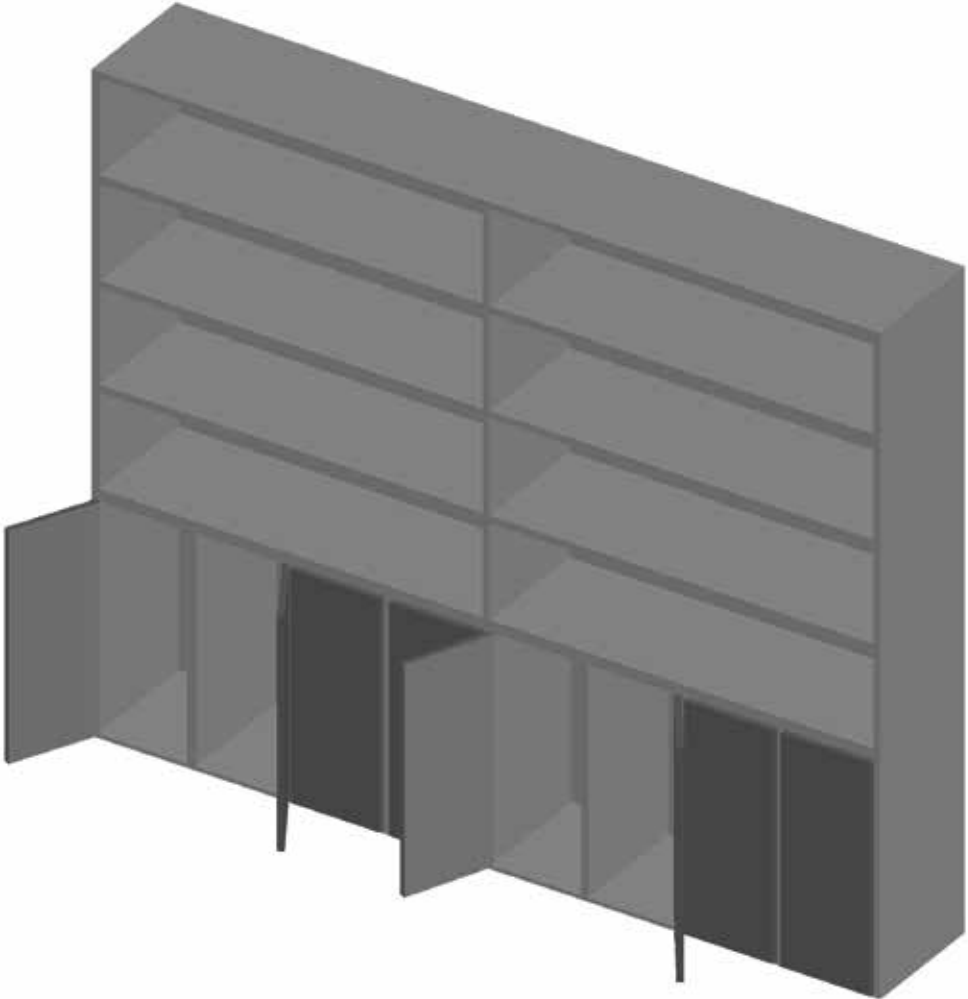

MC 1.76



MC 1.77

SOLO ESPECIFICACIÓN TÉCNICA

MC 1.78

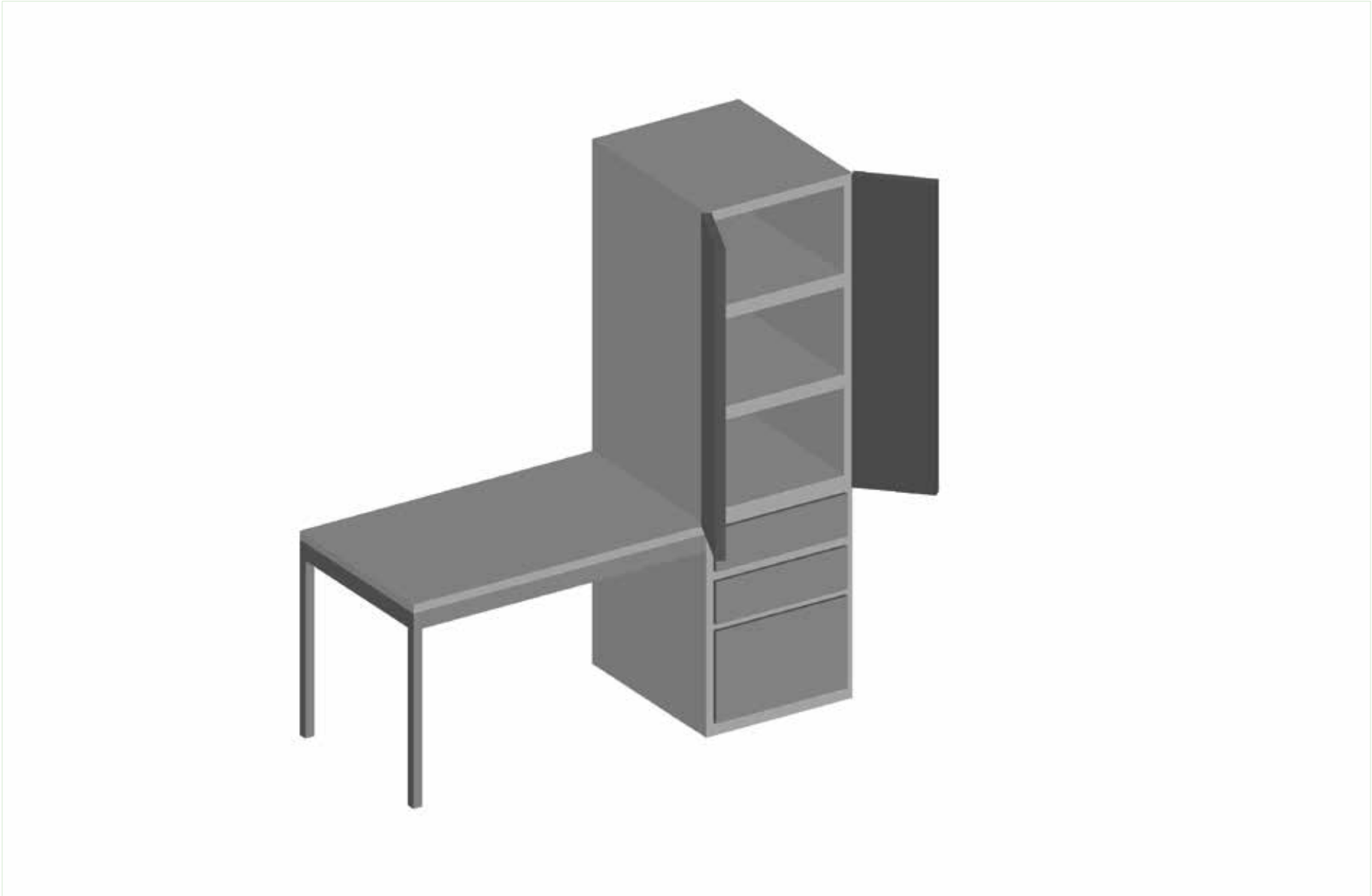

MC 1.79

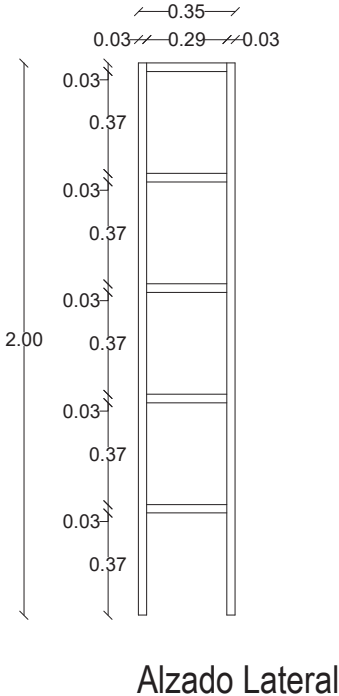
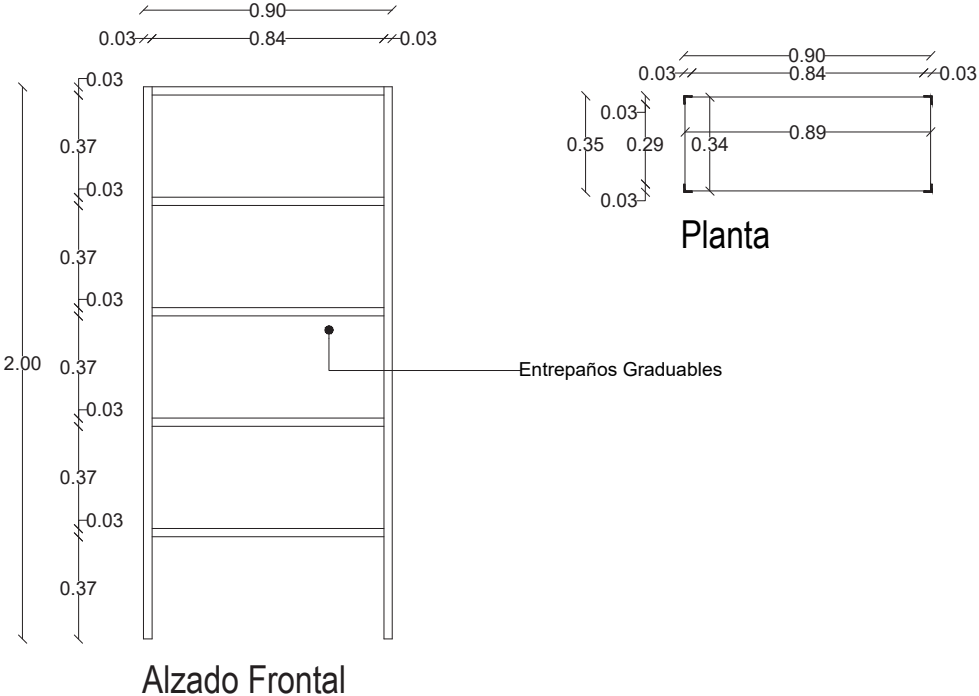

MC 1.80

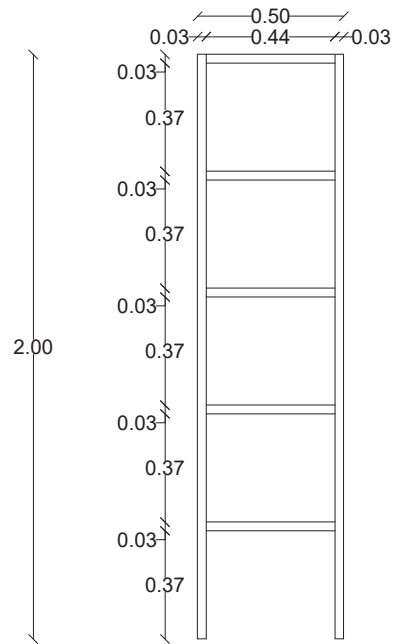
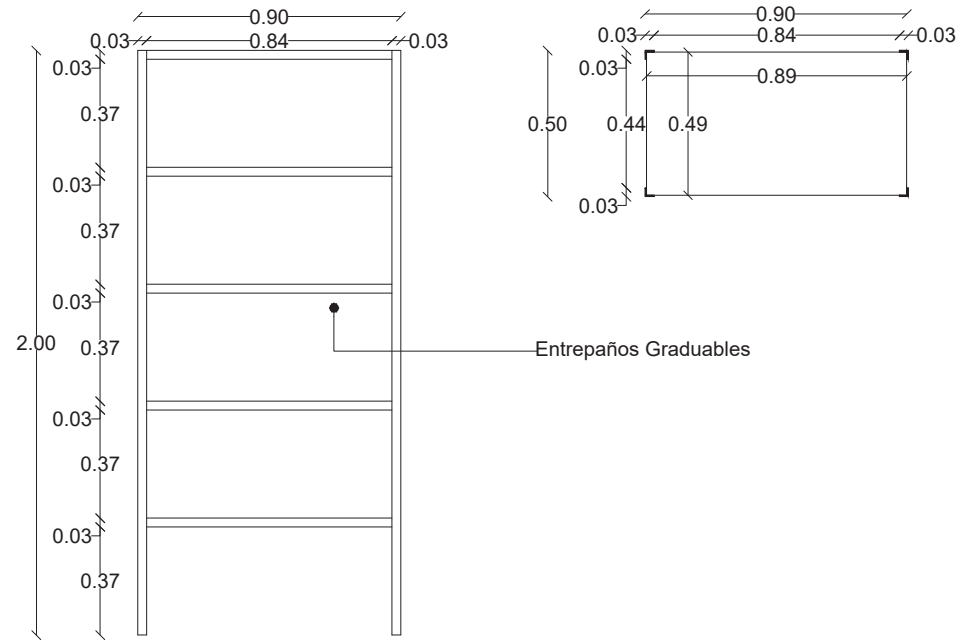

MC 1.81

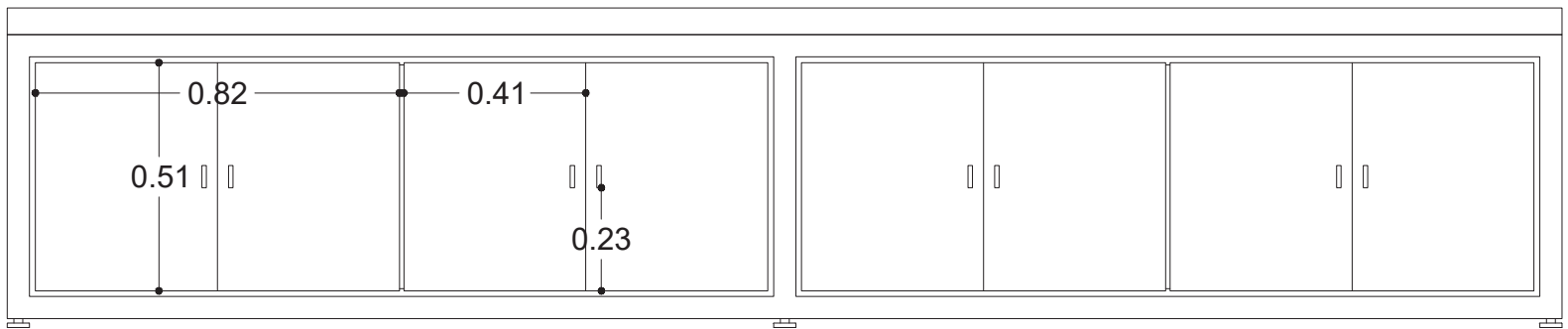
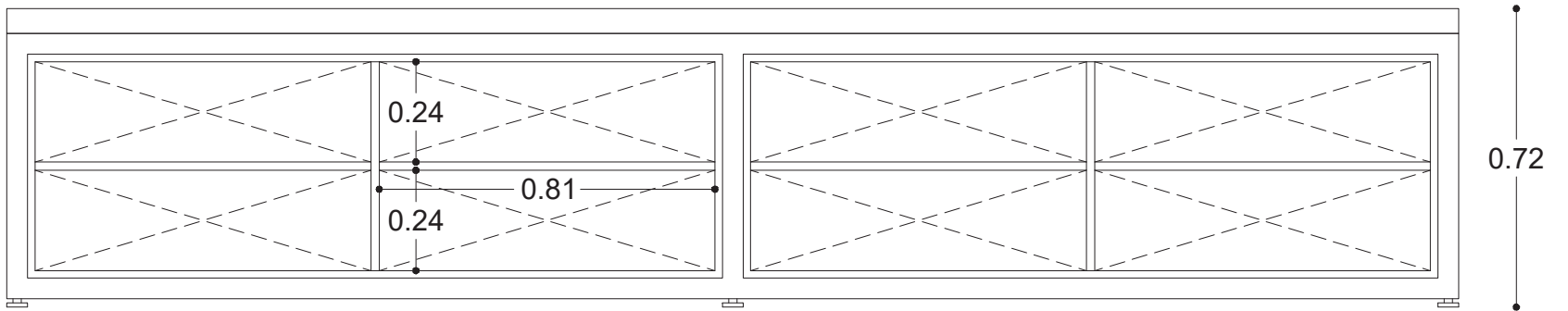
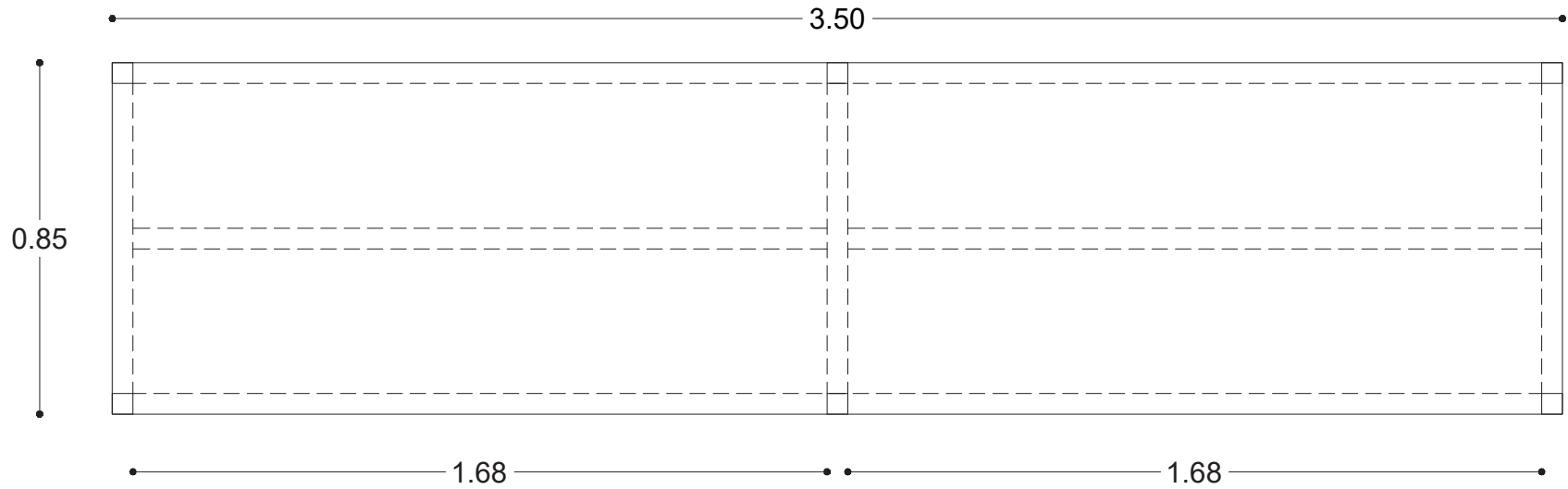

SOLO ESPECIFICACIÓN TÉCNICA

MC 1.83

SOLO ESPECIFICACIÓN TÉCNICA

MC 1.84

SOLO ESPECIFICACIÓN TÉCNICA

MC 1.85

SOLO ESPECIFICACIÓN TÉCNICA

MC 1.86

SOLO ESPECIFICACIÓN TÉCNICA

MC 1.87

SOLO ESPECIFICACIÓN TÉCNICA

MC 1.88

SOLO ESPECIFICACIÓN TÉCNICA

MC 1.89

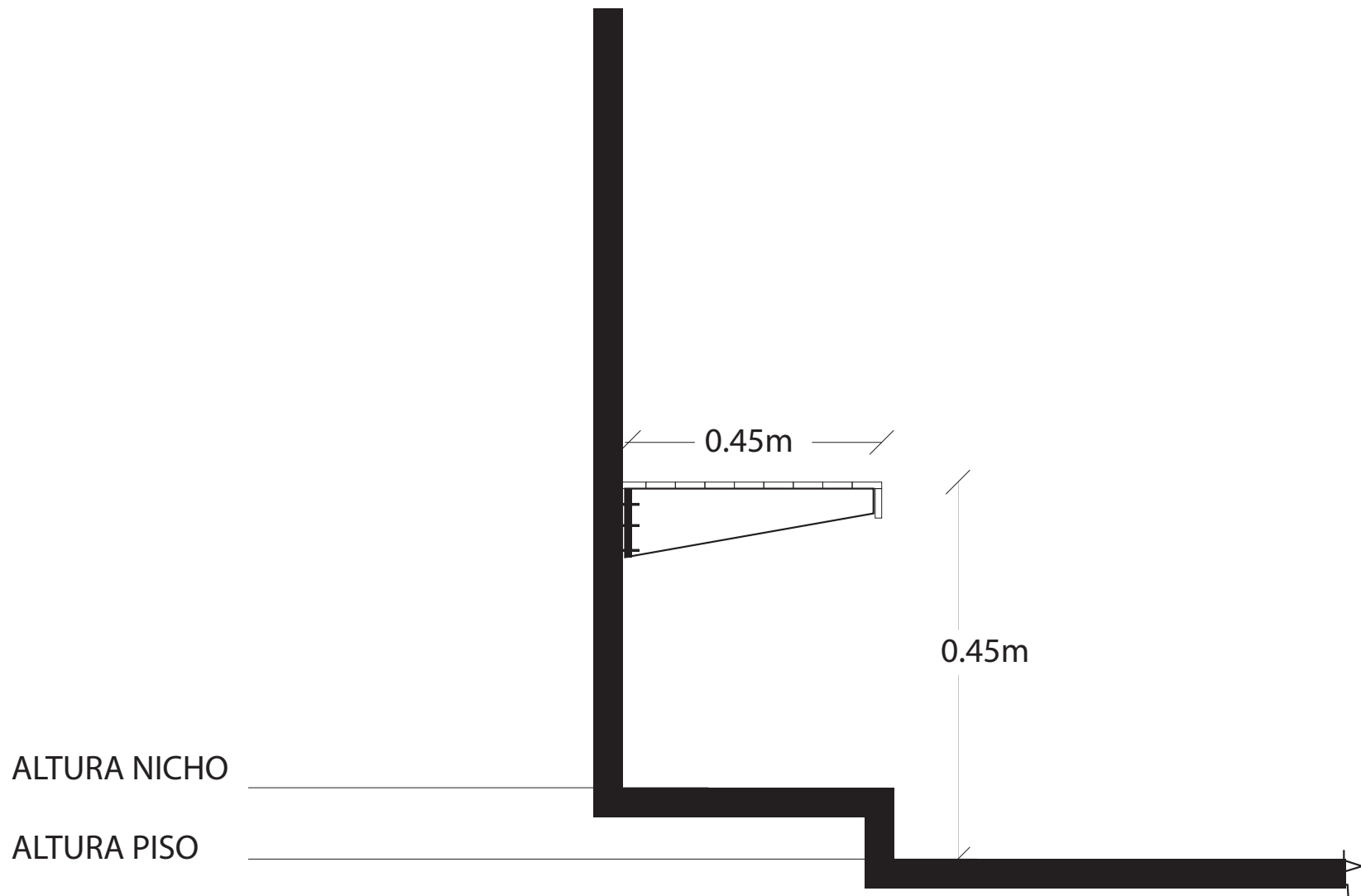

MC 1.90

SOLO ESPECIFICACIÓN TÉCNICA

MC 1.91

SOLO ESPECIFICACIÓN TÉCNICA

MC 1.92

VISTA EN PLANTA

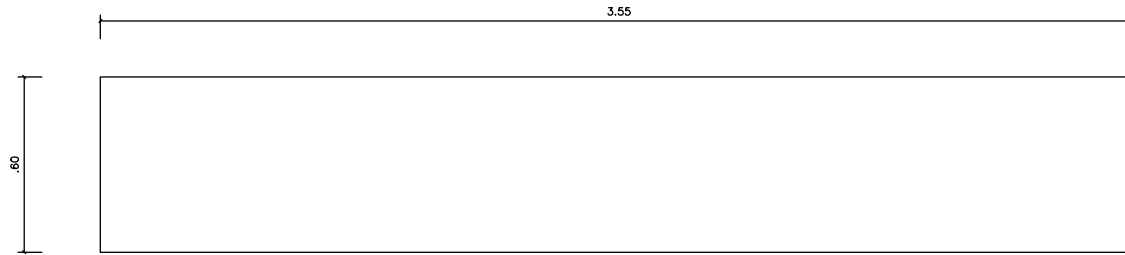

ALZADO
MUEBLE ABIERTO

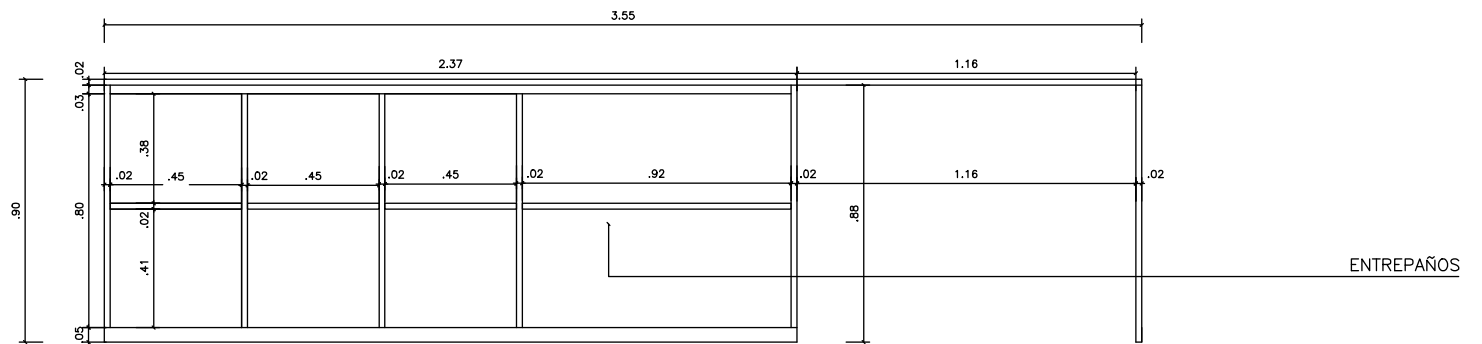

ALZADO
MUEBLE CERRADO

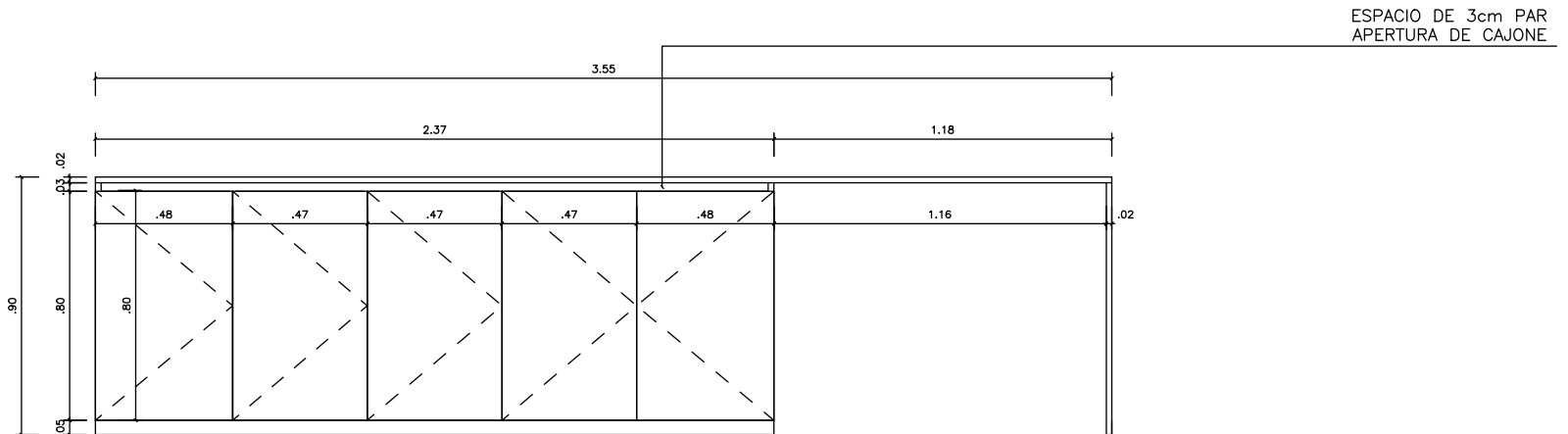

MC 1.94

SOLO ESPECIFICACIÓN TÉCNICA

MC 1.95

SOLO ESPECIFICACIÓN TÉCNICA

MC 1.96

SOLO ESPECIFICACIÓN TÉCNICA

MC 1.97

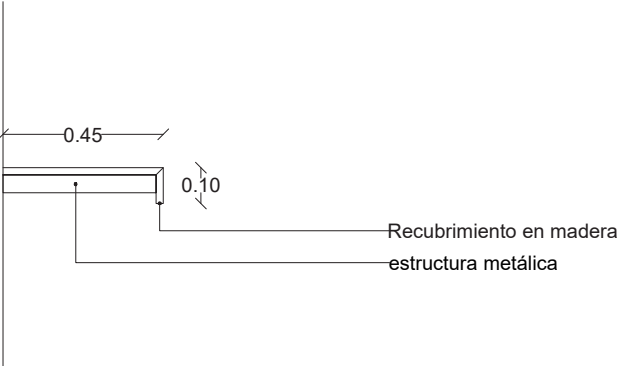
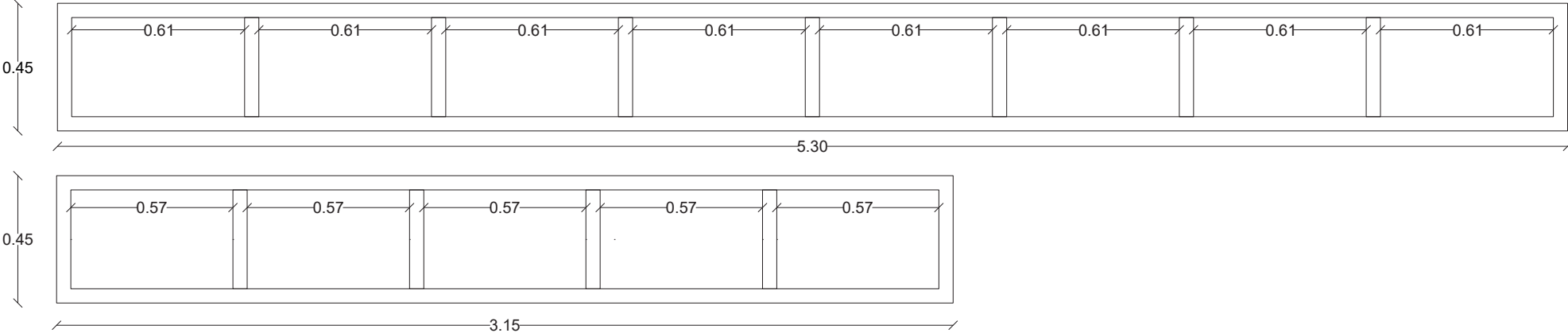

MC 1.98

SOLO ESPECIFICACIÓN TÉCNICA

MC 1.99

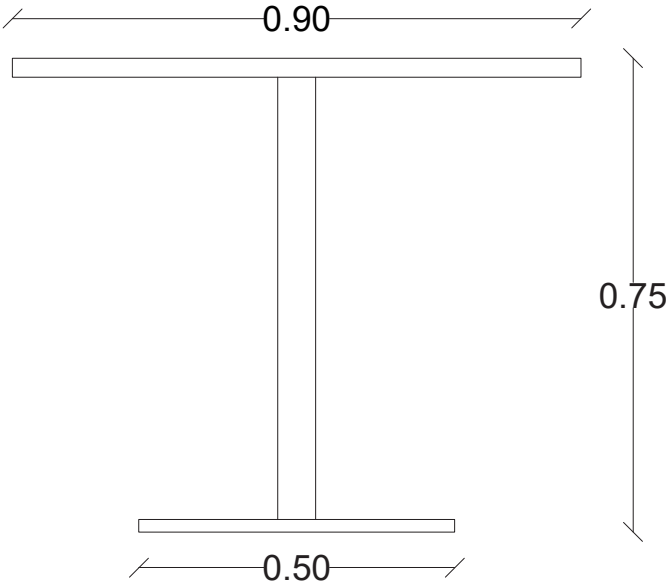
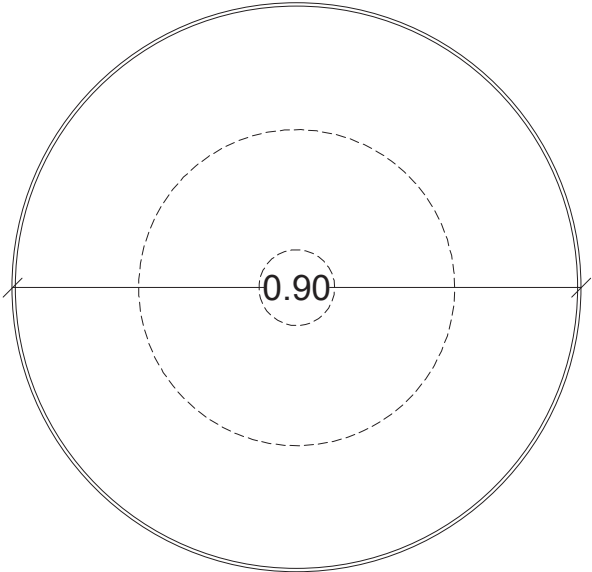

MC 1.100

VISTA EN PLANTA

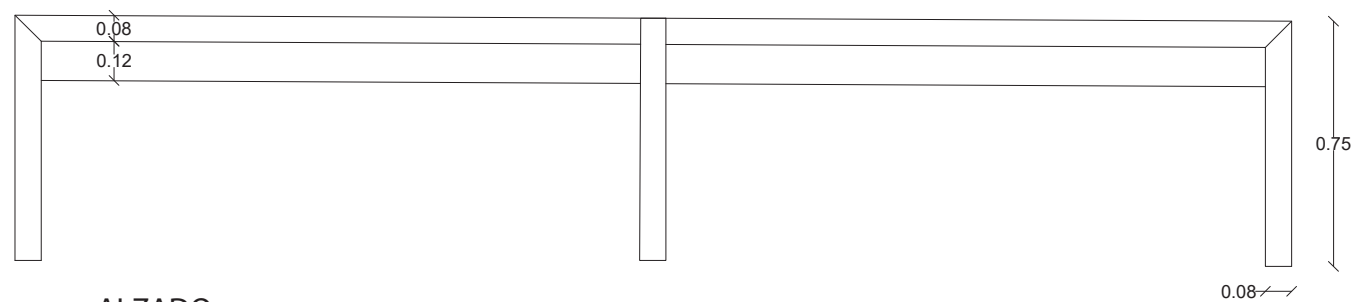
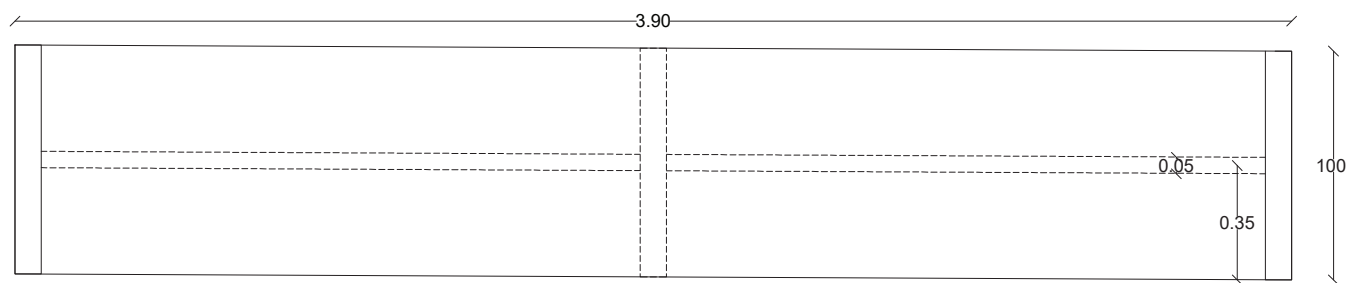
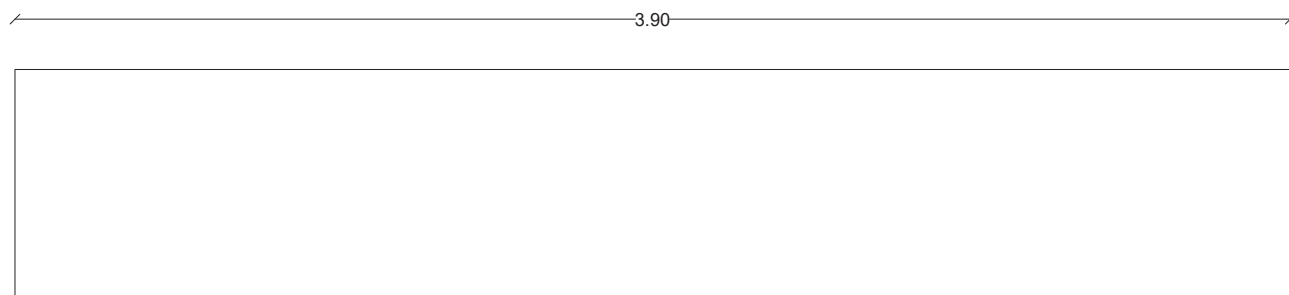

ALZADO



MC 1.101

MC 2.8

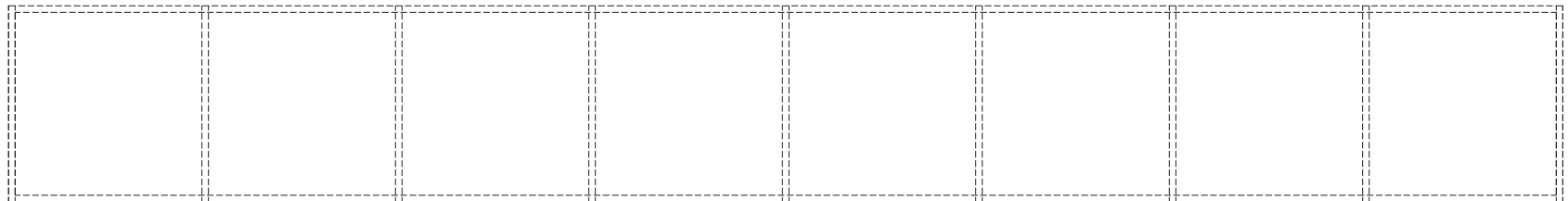
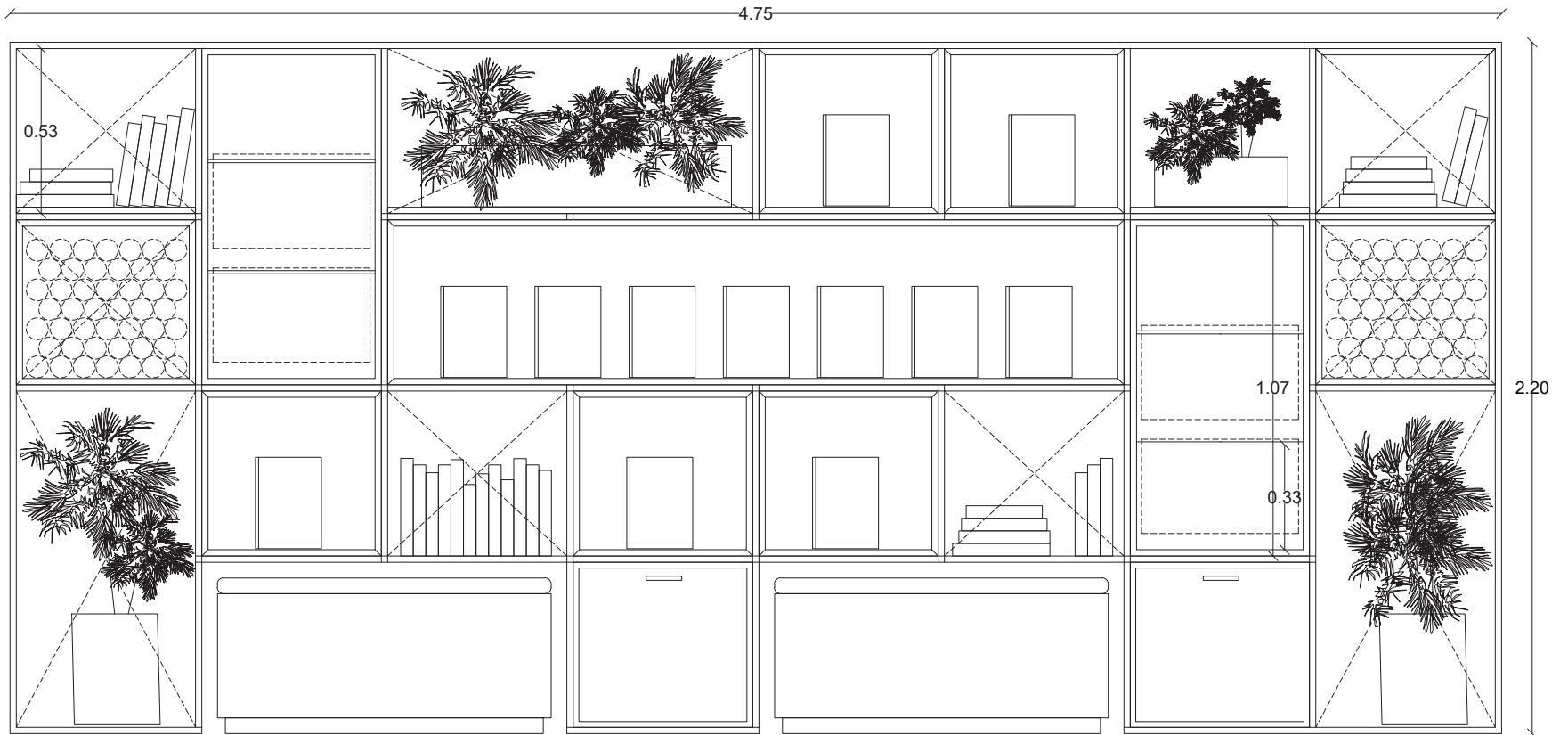

MC 1.102

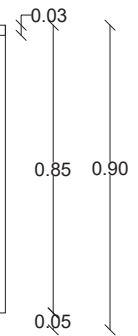
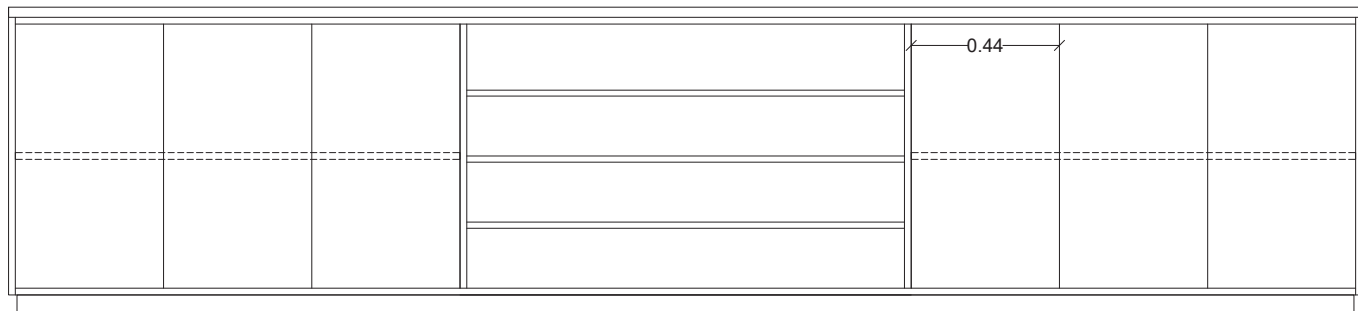
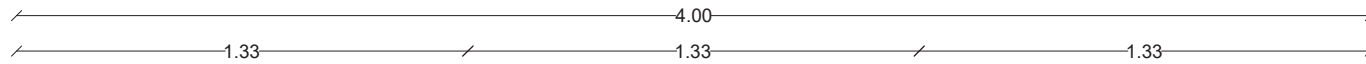
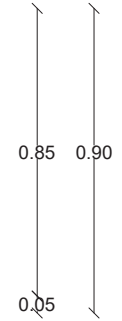
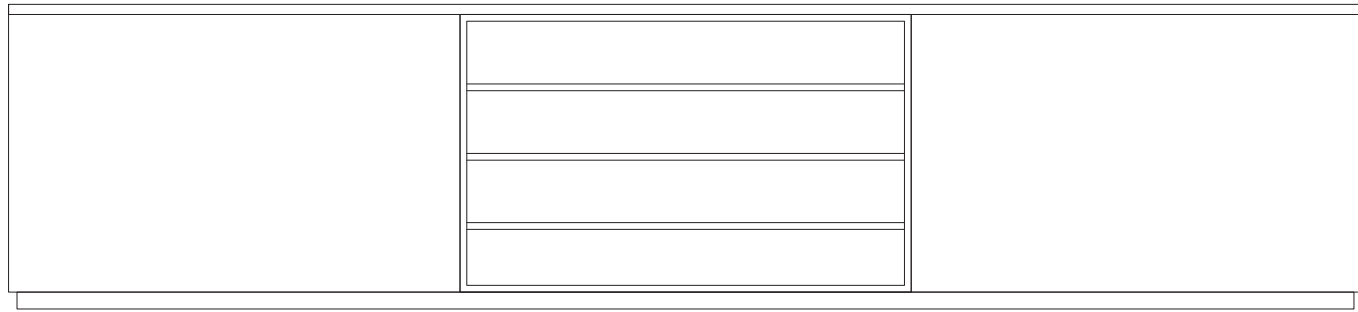
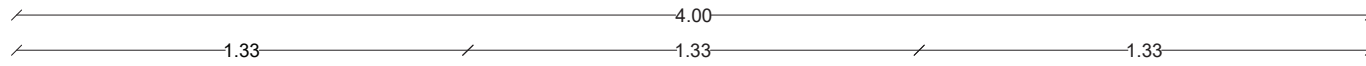

MC 1.103

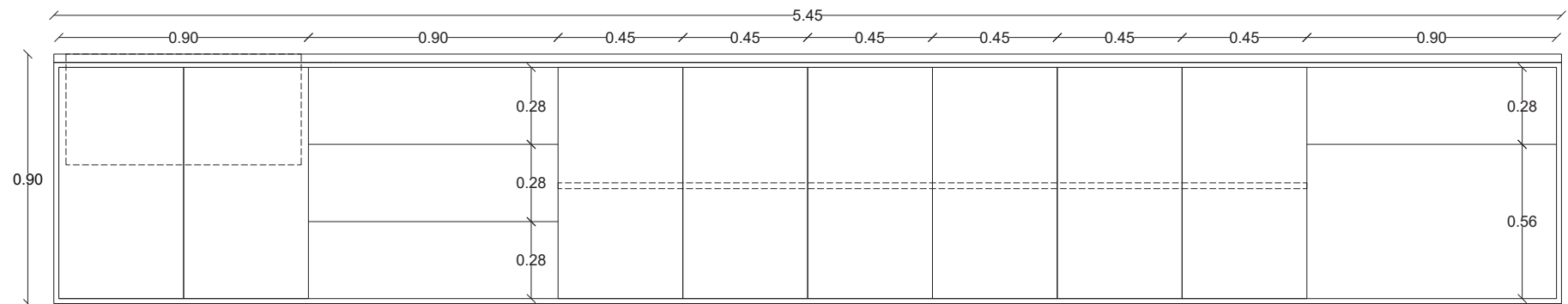
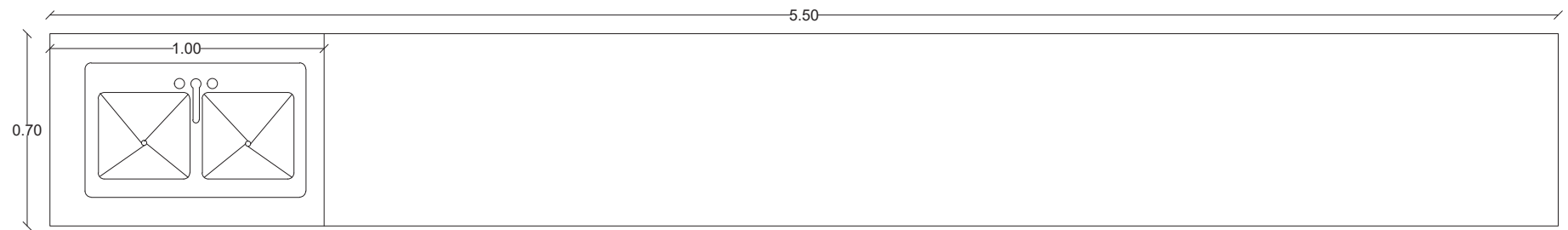

MC 1.104

SOLO ESPECIFICACIÓN TÉCNICA

MC 1.105

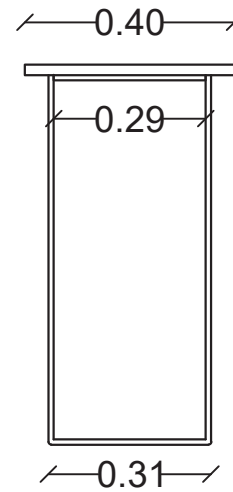
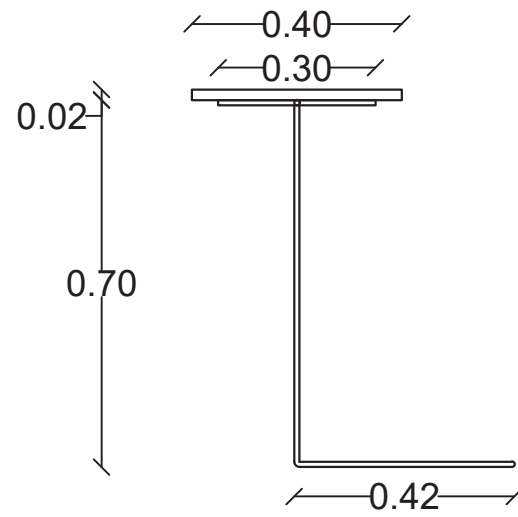
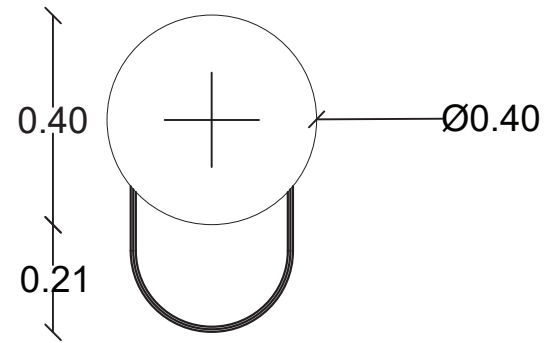
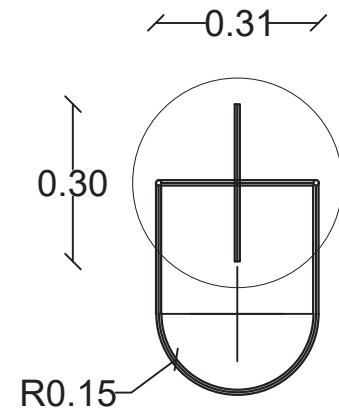

SOLO ESPECIFICACIÓN TÉCNICA



MC 1.107

VISTA EN PLANTA

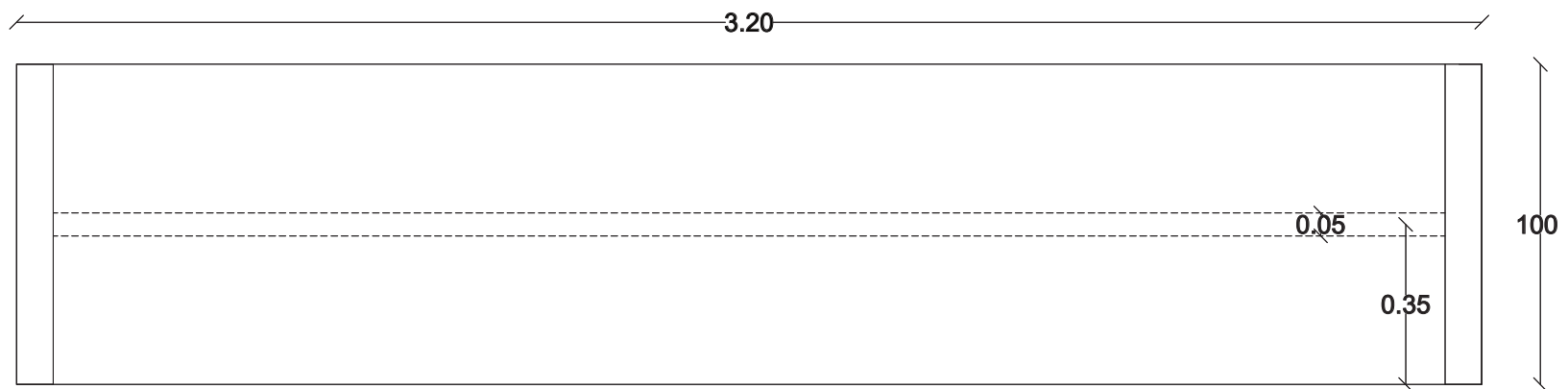

ALZADO



SOLO ESPECIFICACIÓN TÉCNICA



SOLO ESPECIFICACIÓN TÉCNICA



MC 1.110

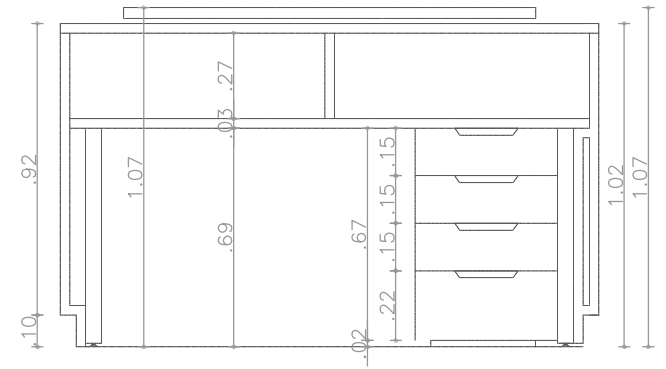
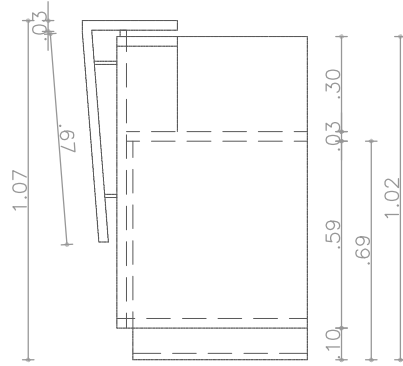
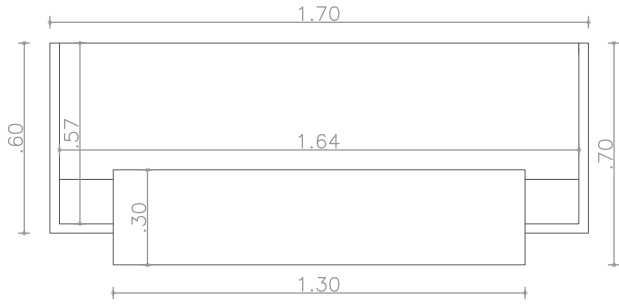

MC 1.111

SOLO ESPECIFICACIÓN TÉCNICA



MC 1.112

SOLO ESPECIFICACIÓN TÉCNICA



MC 1.113

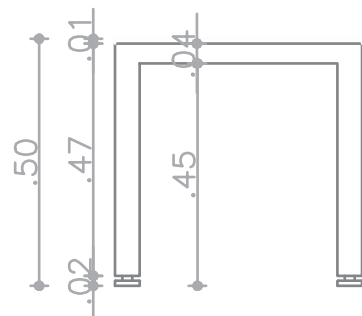
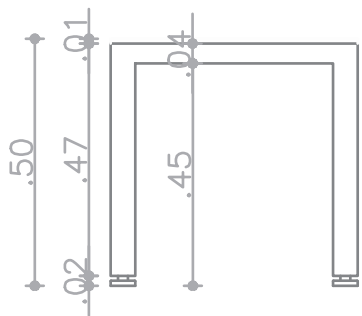
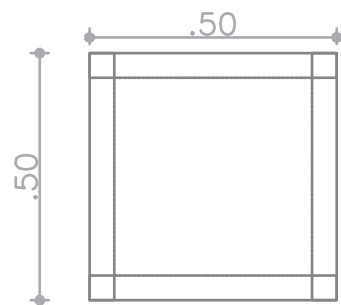

MC 1.114

SOLO ESPECIFICACIÓN TÉCNICA



MC 1.115

SOLO ESPECIFICACIÓN TÉCNICA

MC 1.116

SOLO ESPECIFICACIÓN TÉCNICA

MC 1.117

SOLO ESPECIFICACIÓN TÉCNICA

MC 1.118

Repisa elevada

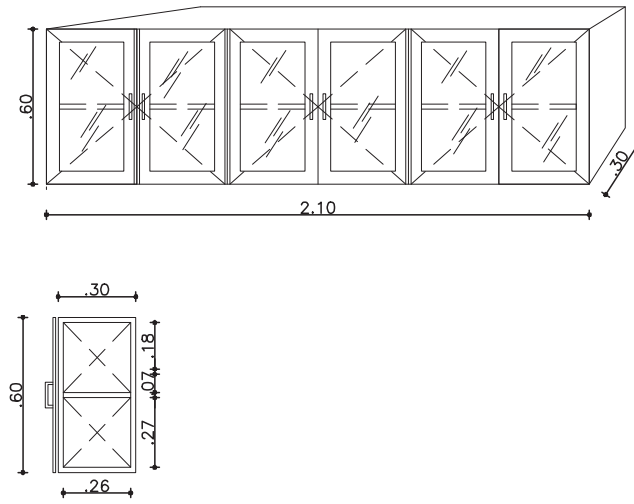
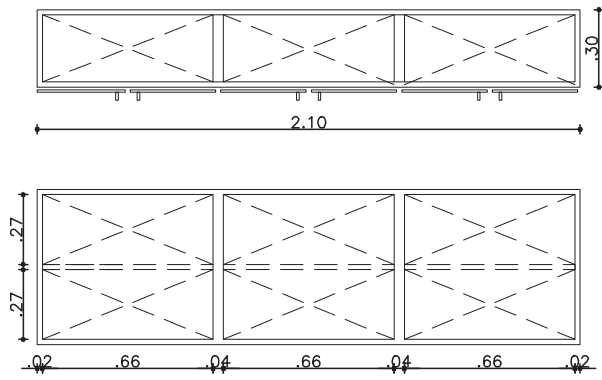

Mueble inferior con poceta

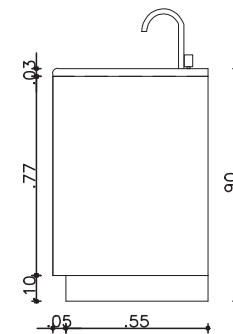
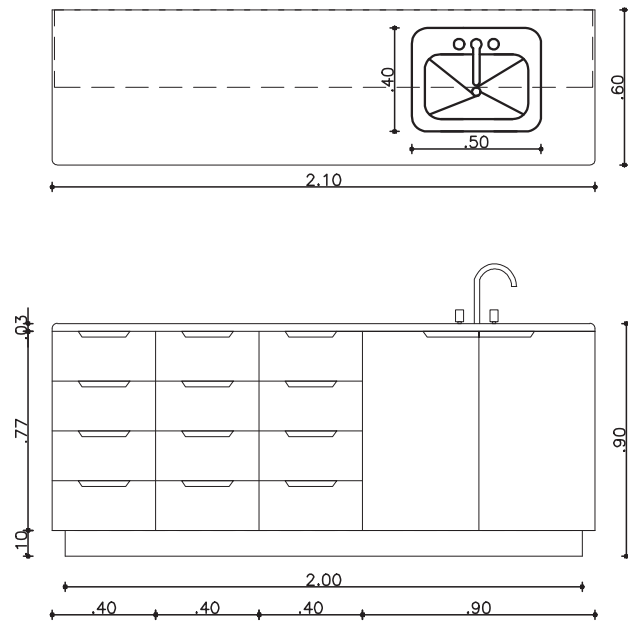

MC 1.119

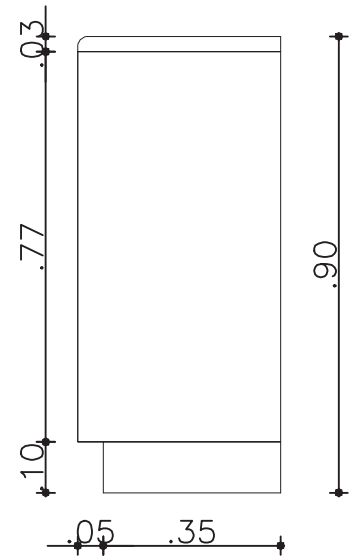
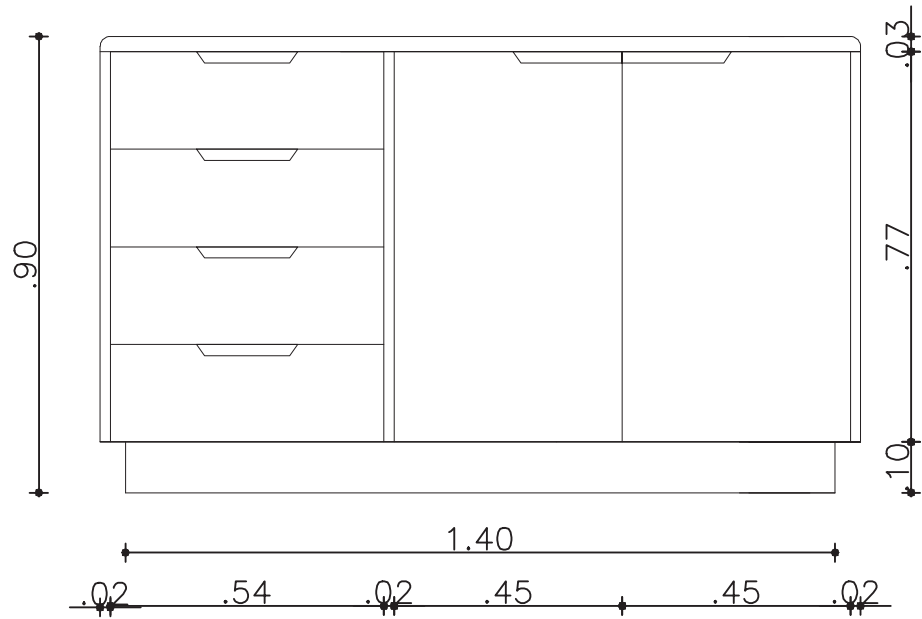
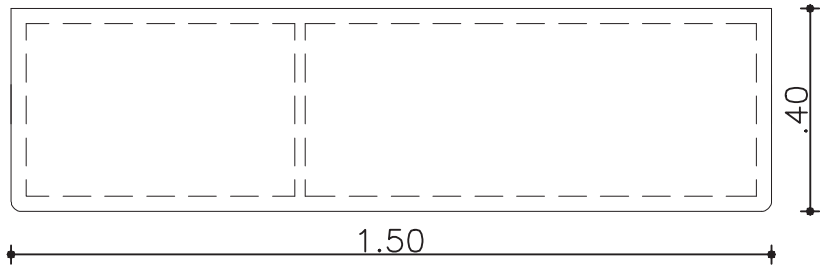

MC 1.120

SOLO ESPECIFICACIÓN TÉCNICA

MC 1.121

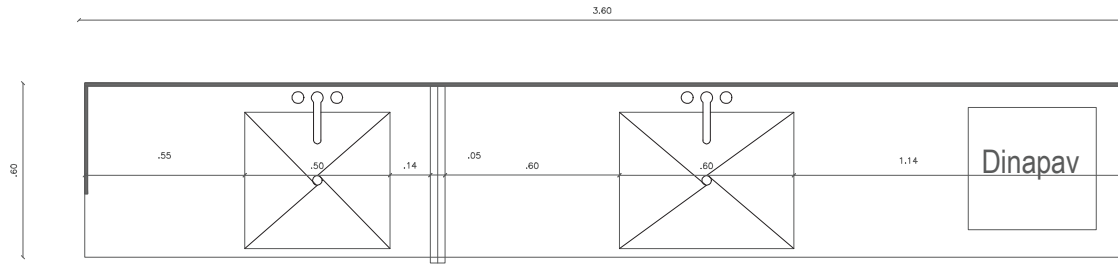

VISTA EN PLANTA

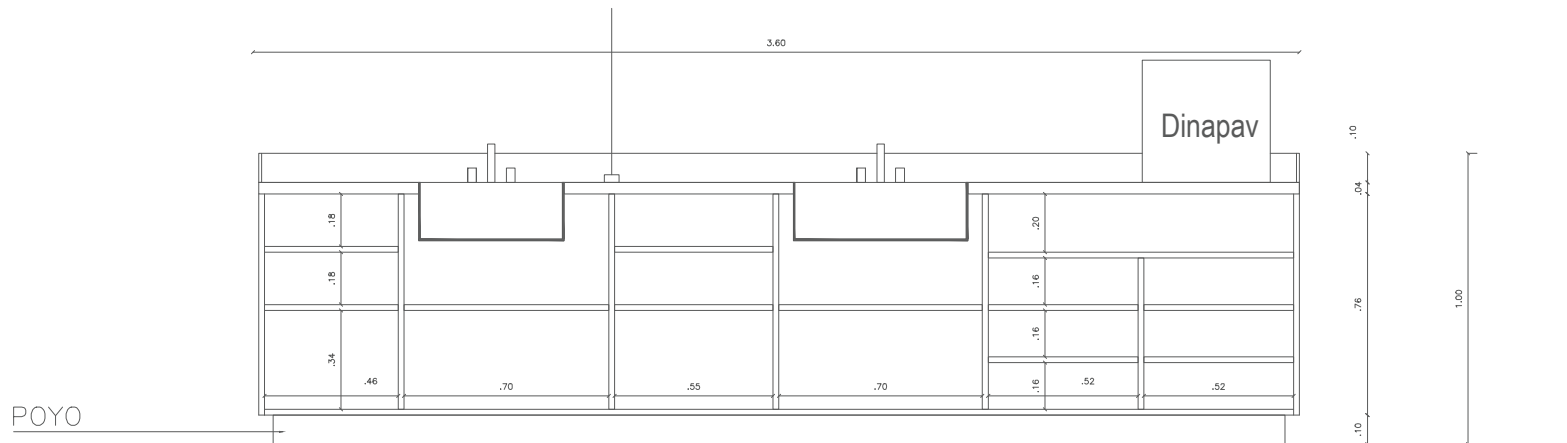

VISTA ALZADO MUEBLE ABIERTO

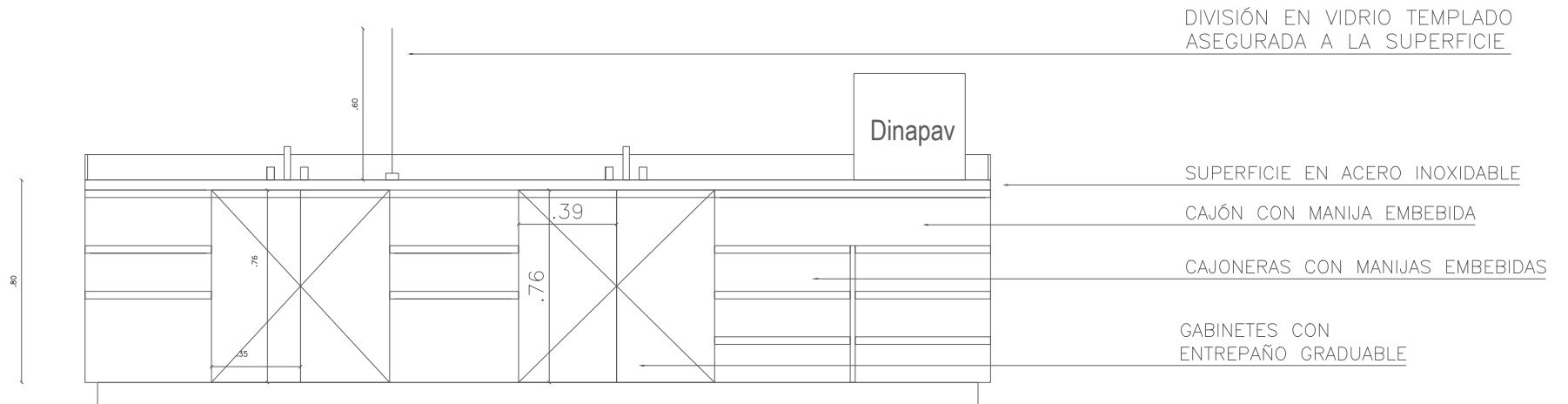

VISTA ALZADO MUEBLE CERRADO

DIVISIÓN EN VIDRIO TEMPLADO
ASEGURADA A LA SUPERFICIE

SUPERFICIE EN ACERO INOXIDABLE

CAJÓN CON MANIJA EMBEBIDA

CAJONERAS CON MANIJAS EMBEBIDAS

GABINETES CON
ENTREPAÑO GRADUABLE

MC 1.122

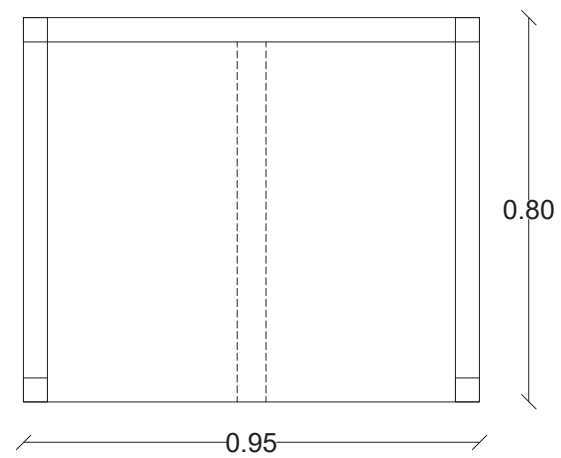
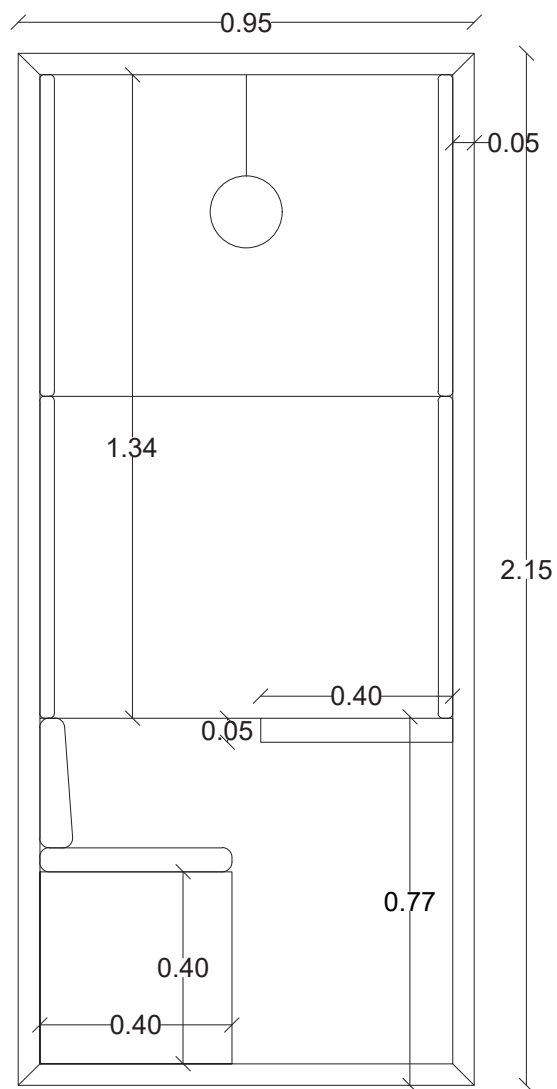

MC 1.123

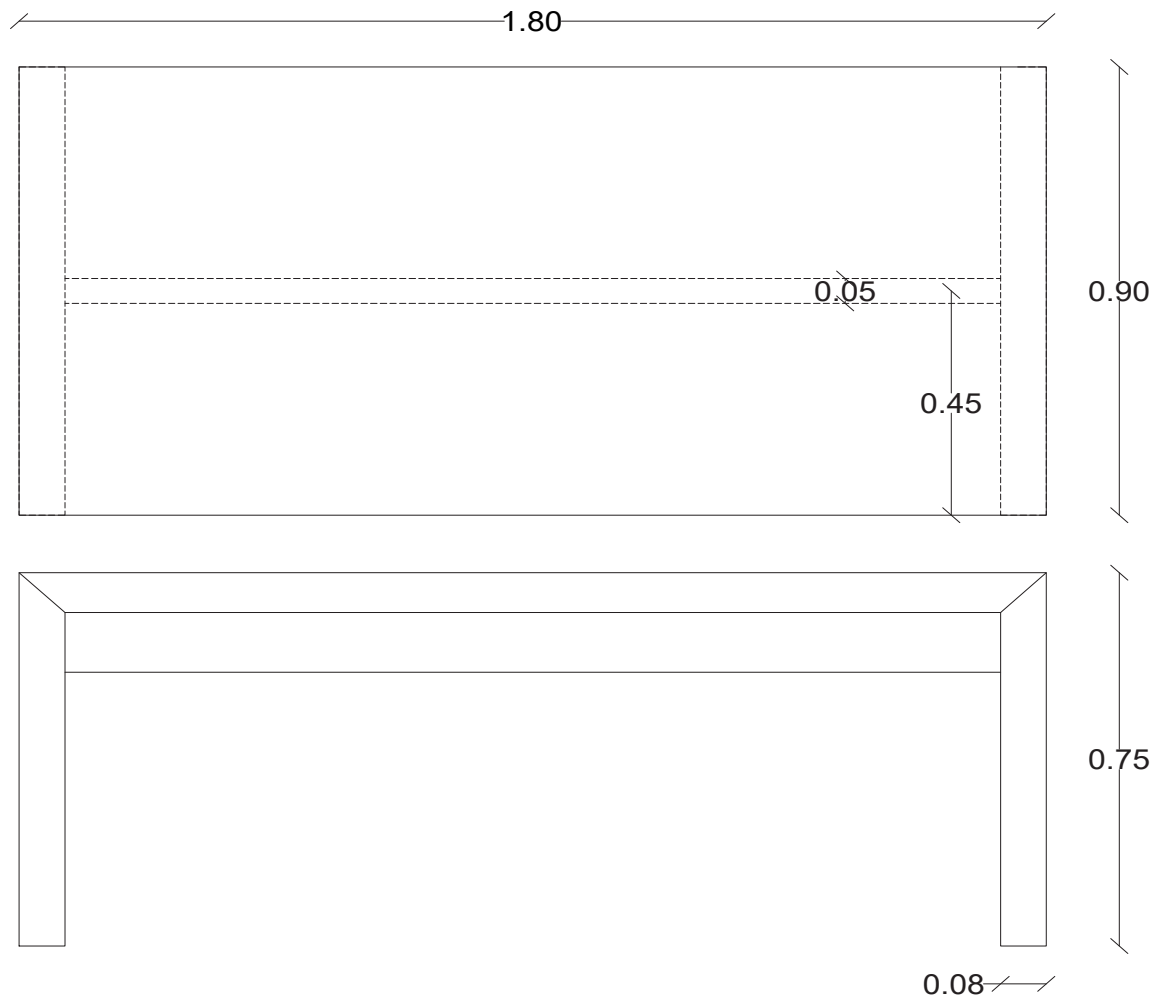

MC 1.124

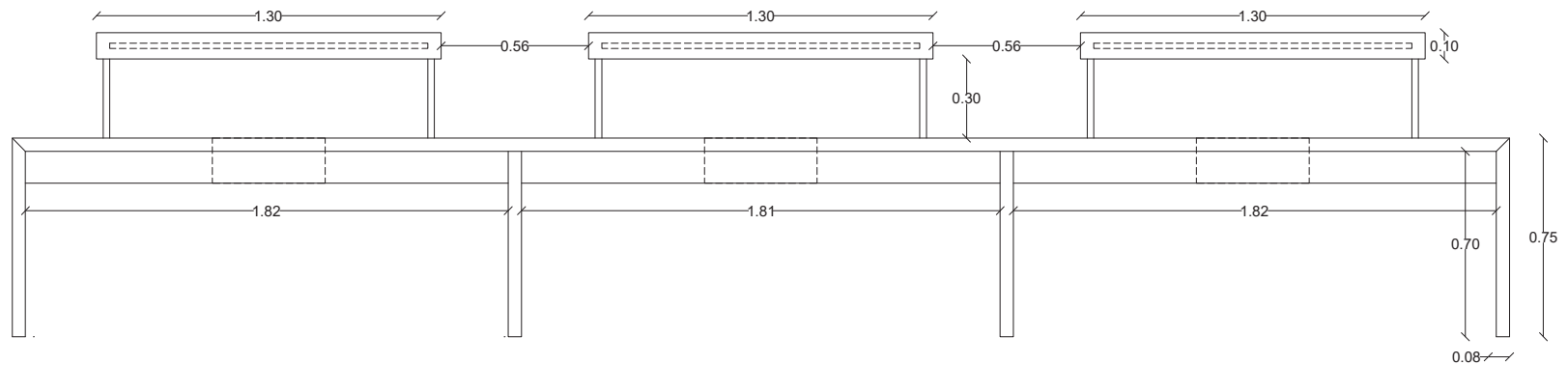
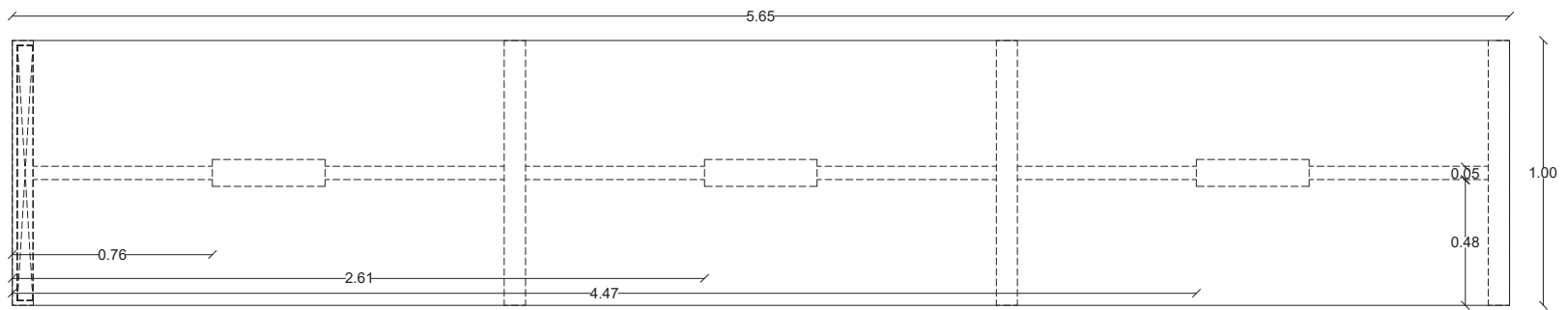
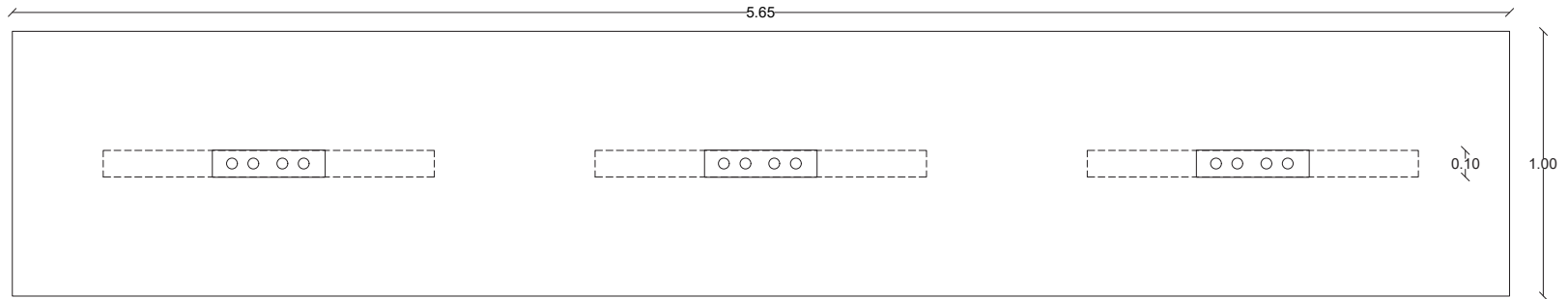

MC 1.125

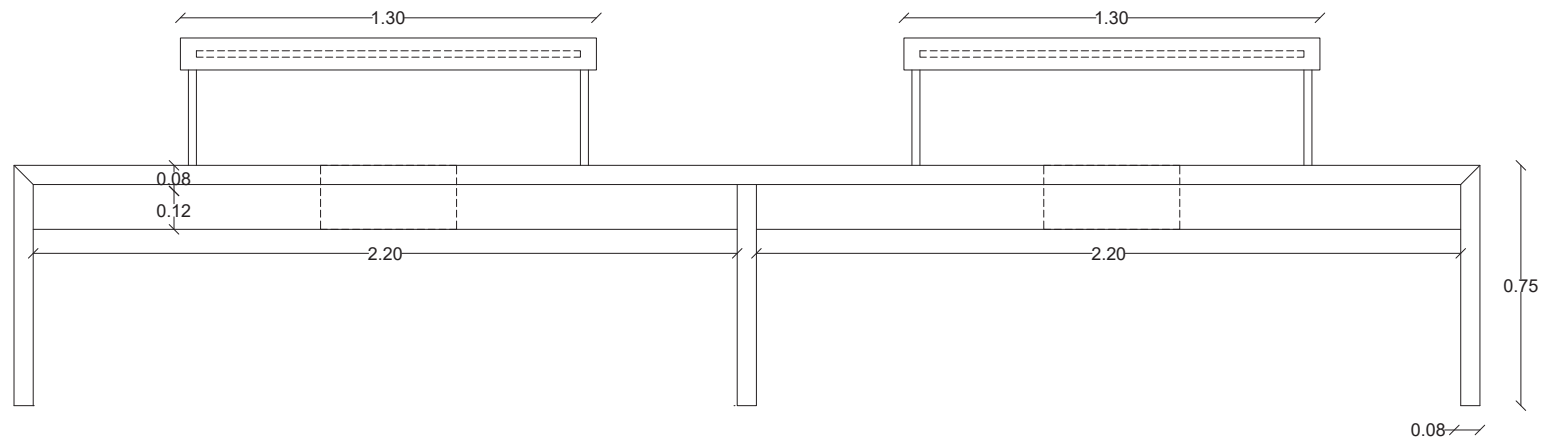
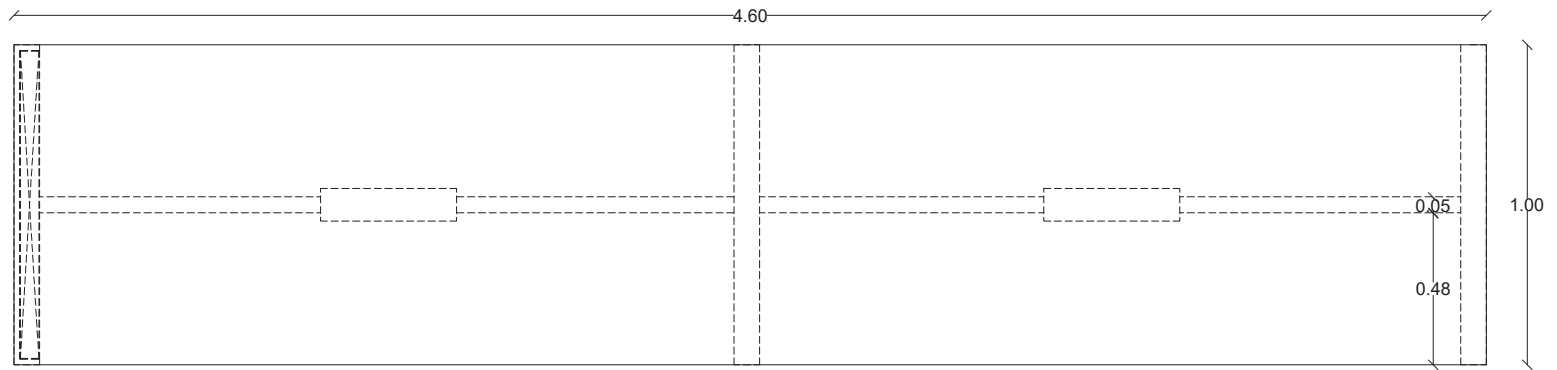
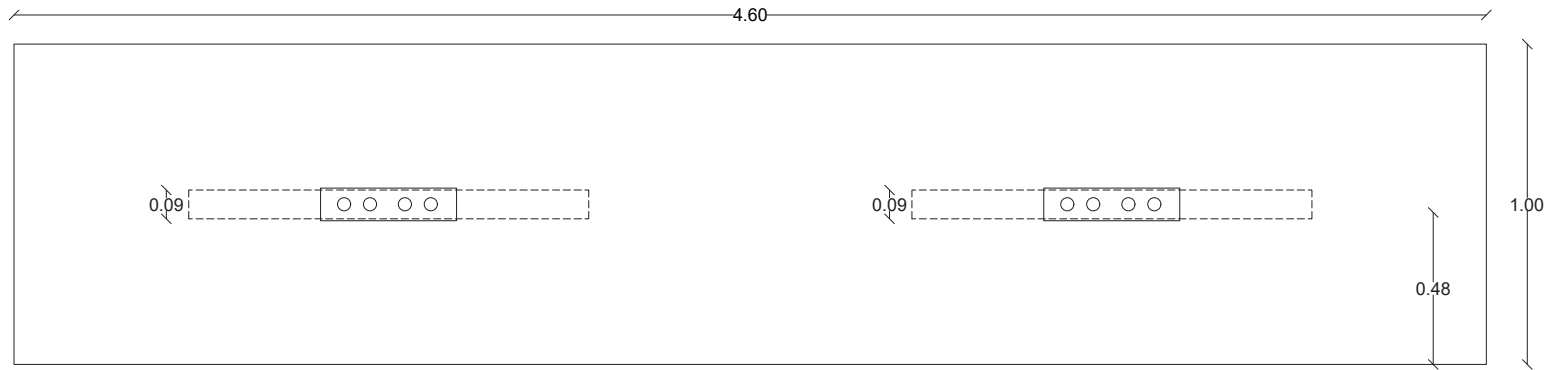

MC 1.127

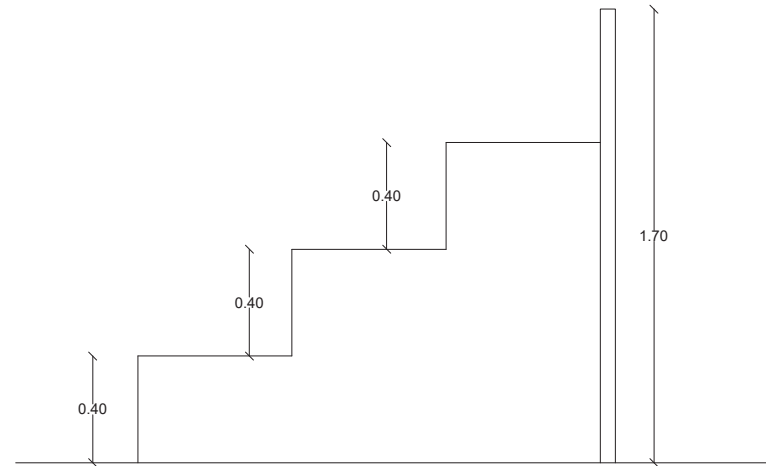
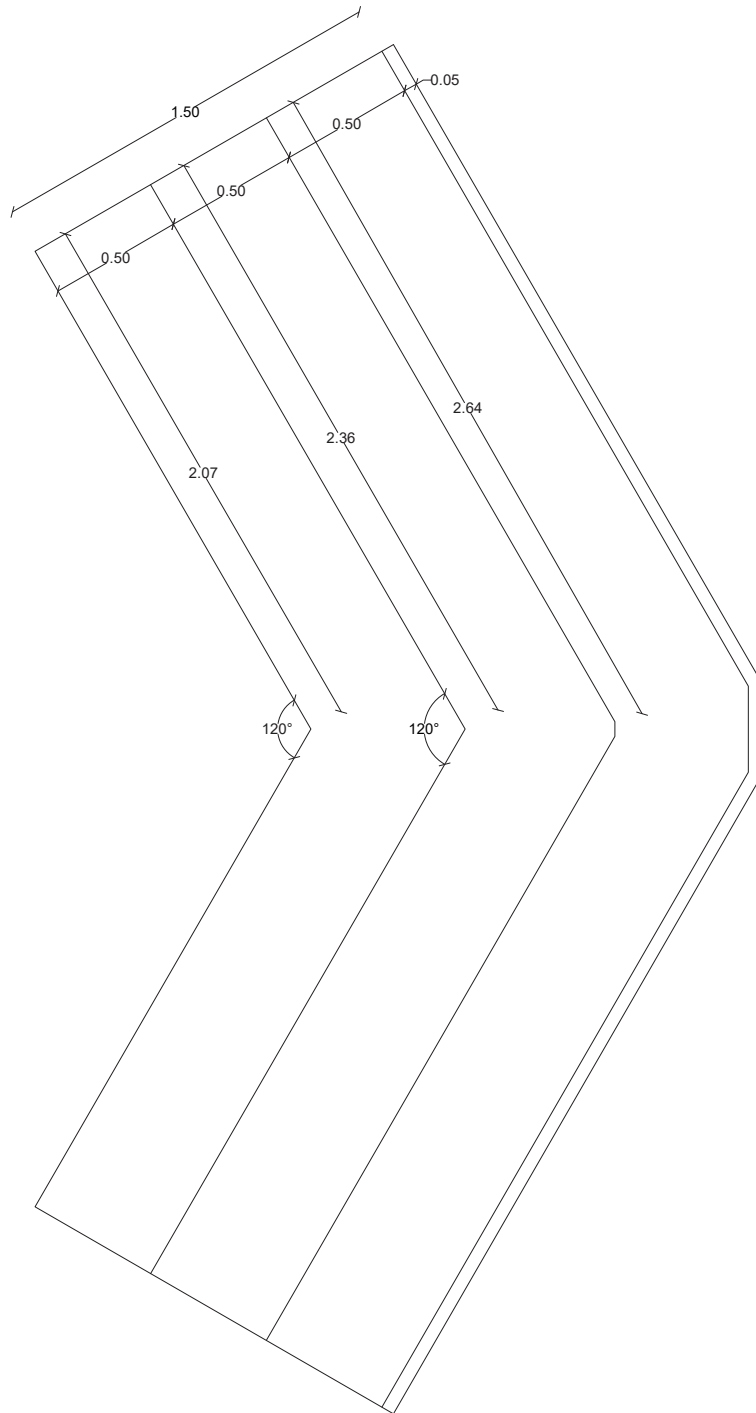

MC 1.128

SOLO ESPECIFICACIÓN TÉCNICA

MC 1.129

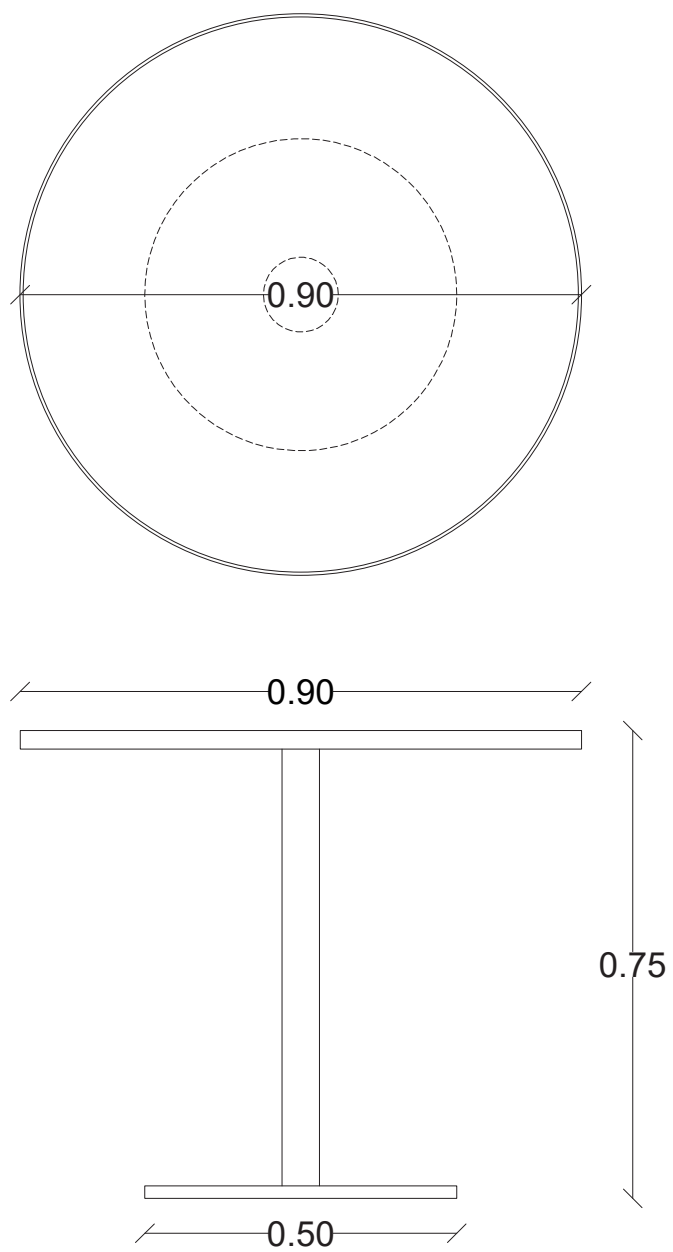

MC 1.130

SOLO ESPECIFICACIÓN TÉCNICA

MC 1.131

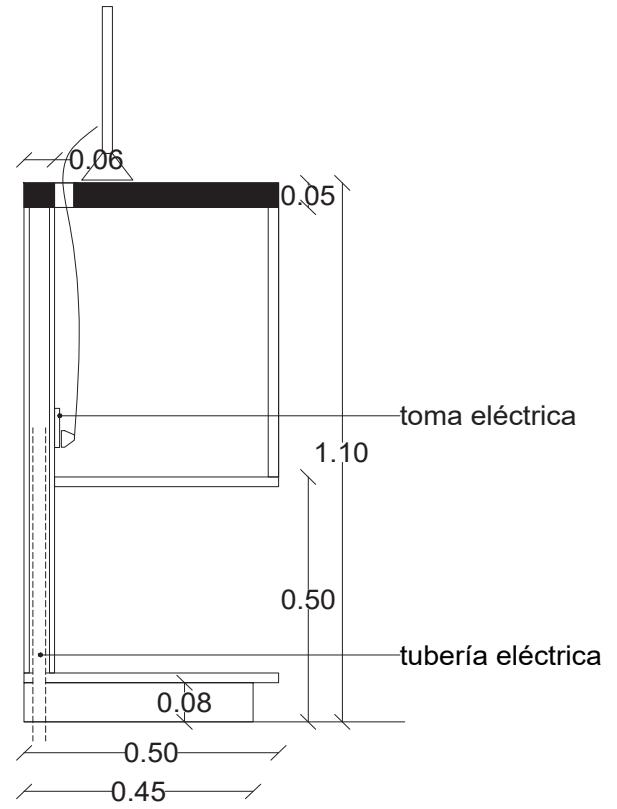
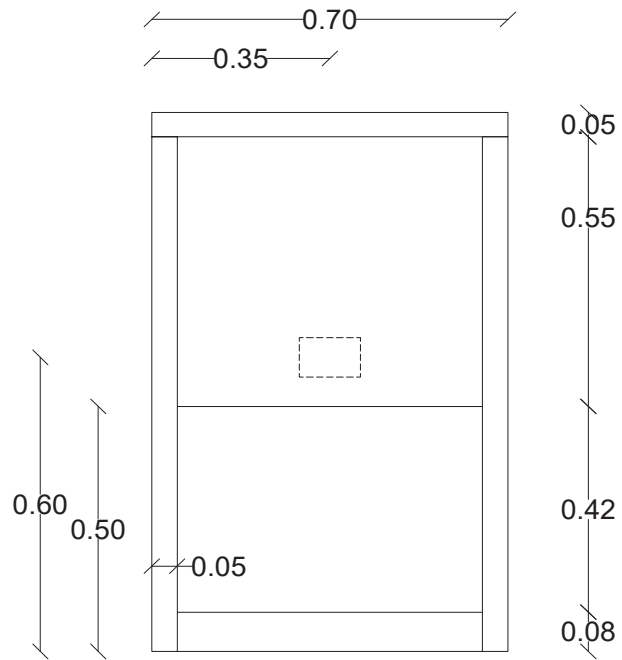
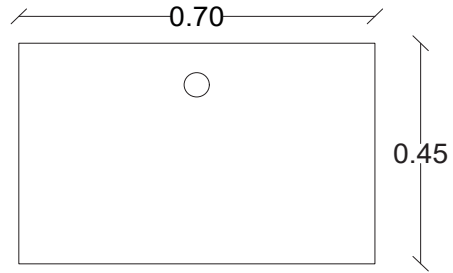

MC 1.132

SOLO ESPECIFICACIÓN TÉCNICA

MC 1.133

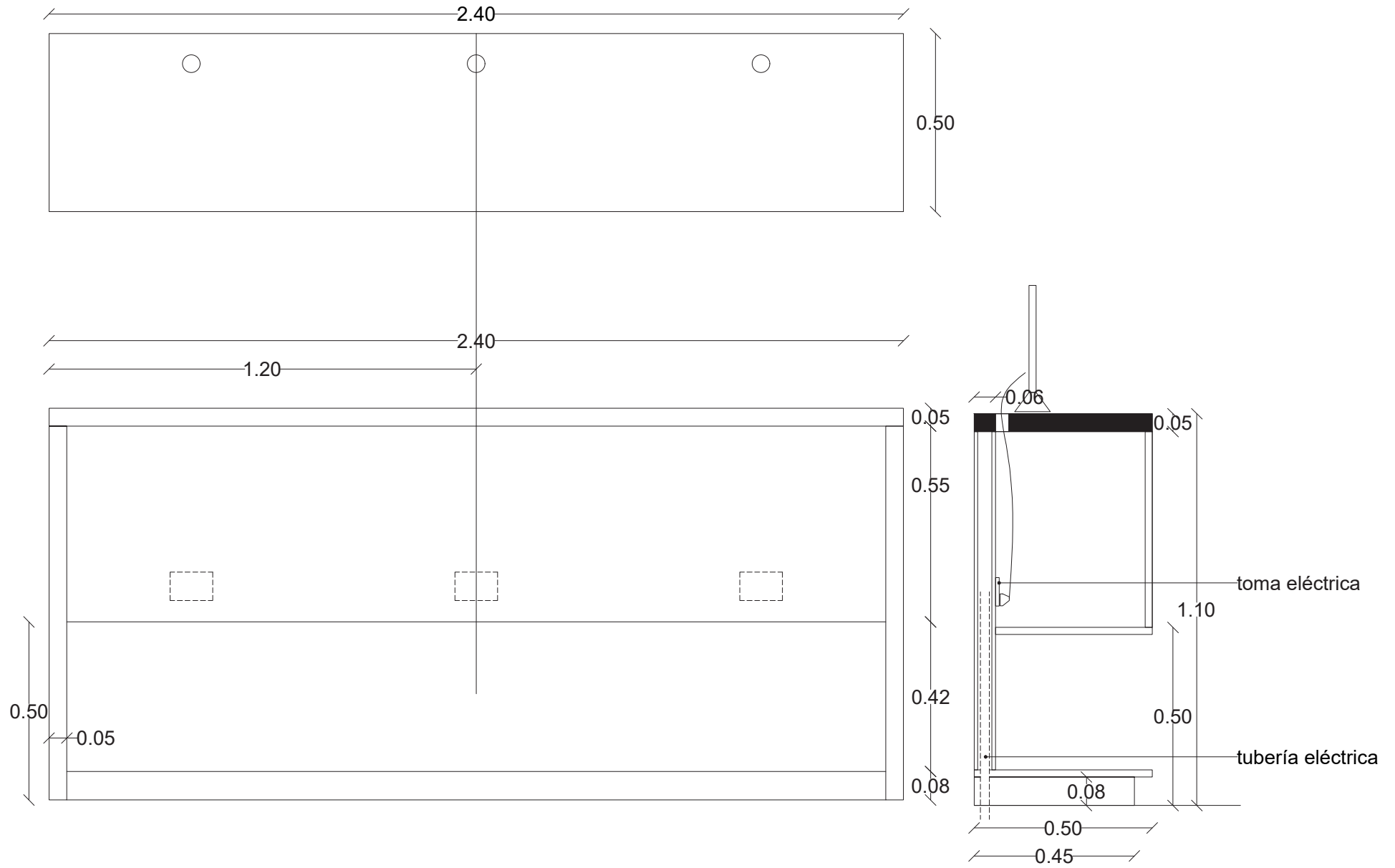

MC 1.134

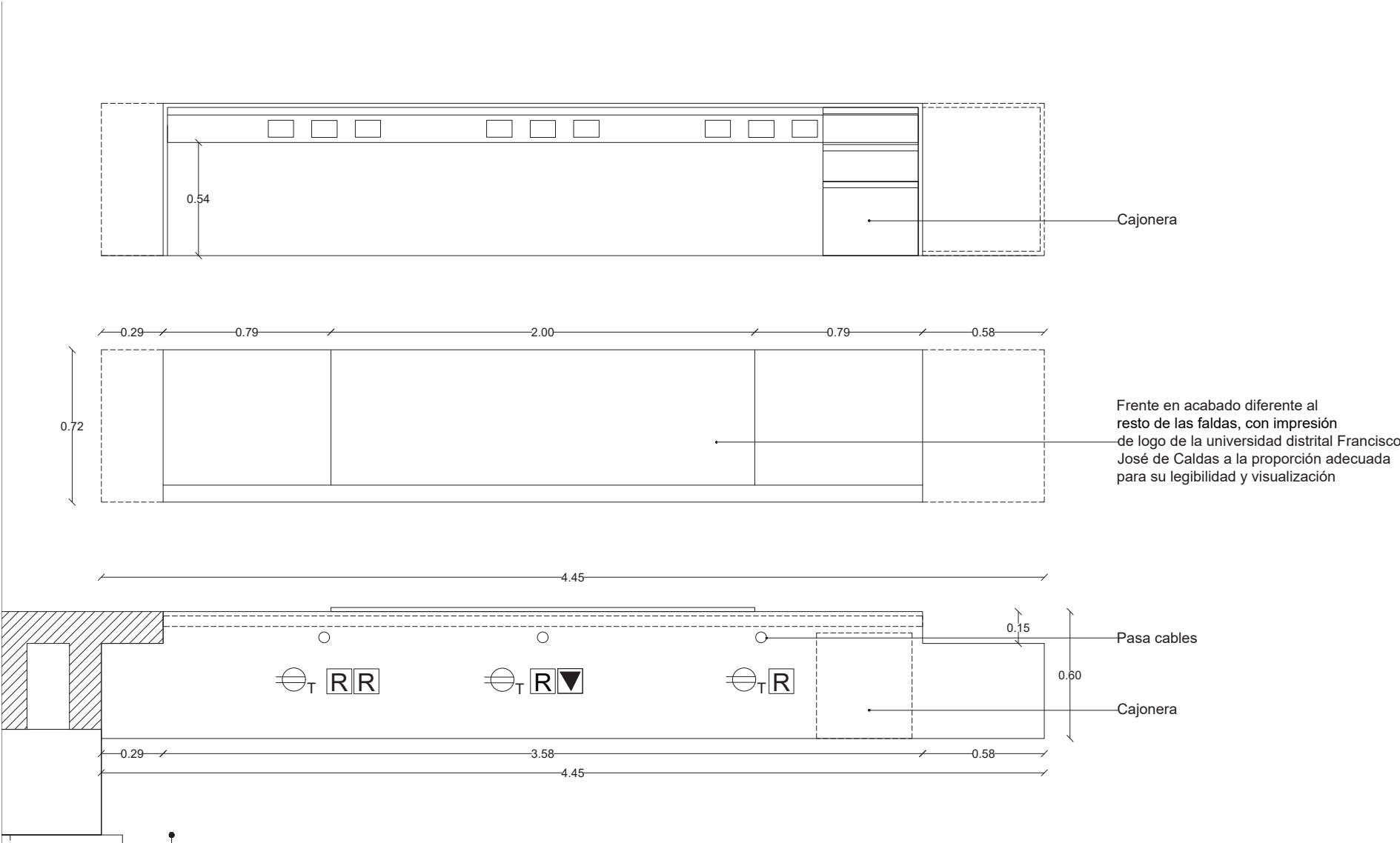

MC 1.135

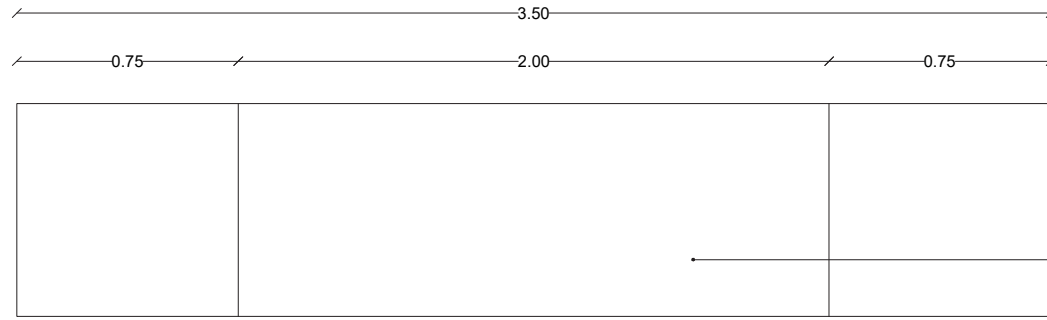

Frente en acabado diferente al resto de las faldas, con impresión de logo de la universidad distrital Francisco José de Caldas a la proporción adecuada para su legibilidad y visualización

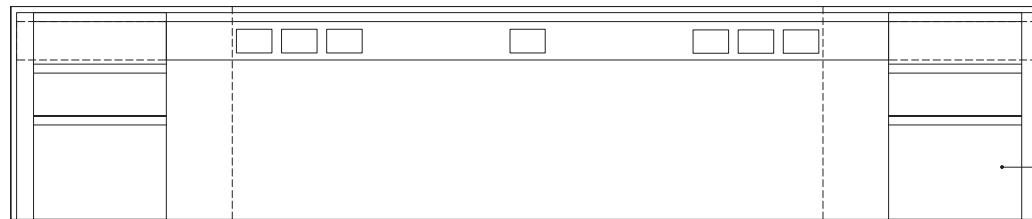

Cajoneras

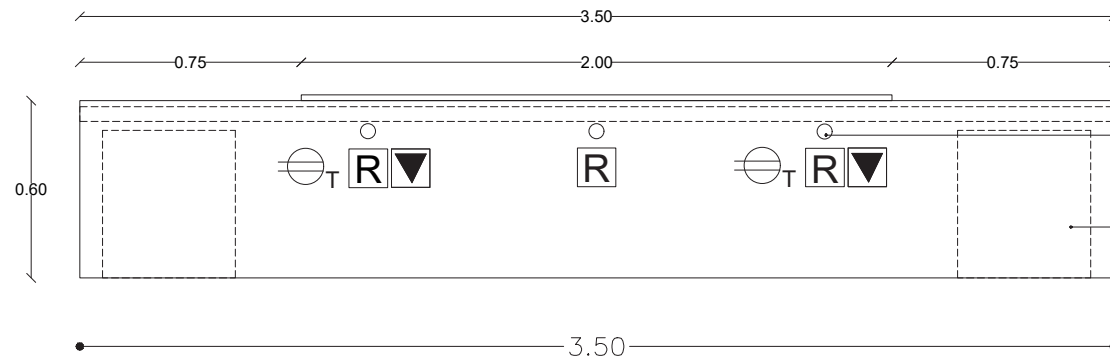

Pasa cables

Cajoneras

MC 1.136

SOLO ESPECIFICACIÓN TÉCNICA

MC 1.137

SOLO ESPECIFICACIÓN TÉCNICA

MC 1.138

SOLO ESPECIFICACIÓN TÉCNICA

MC 1.139

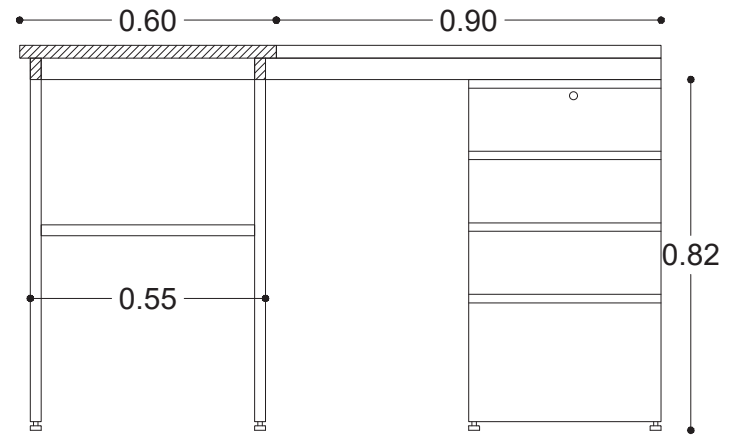
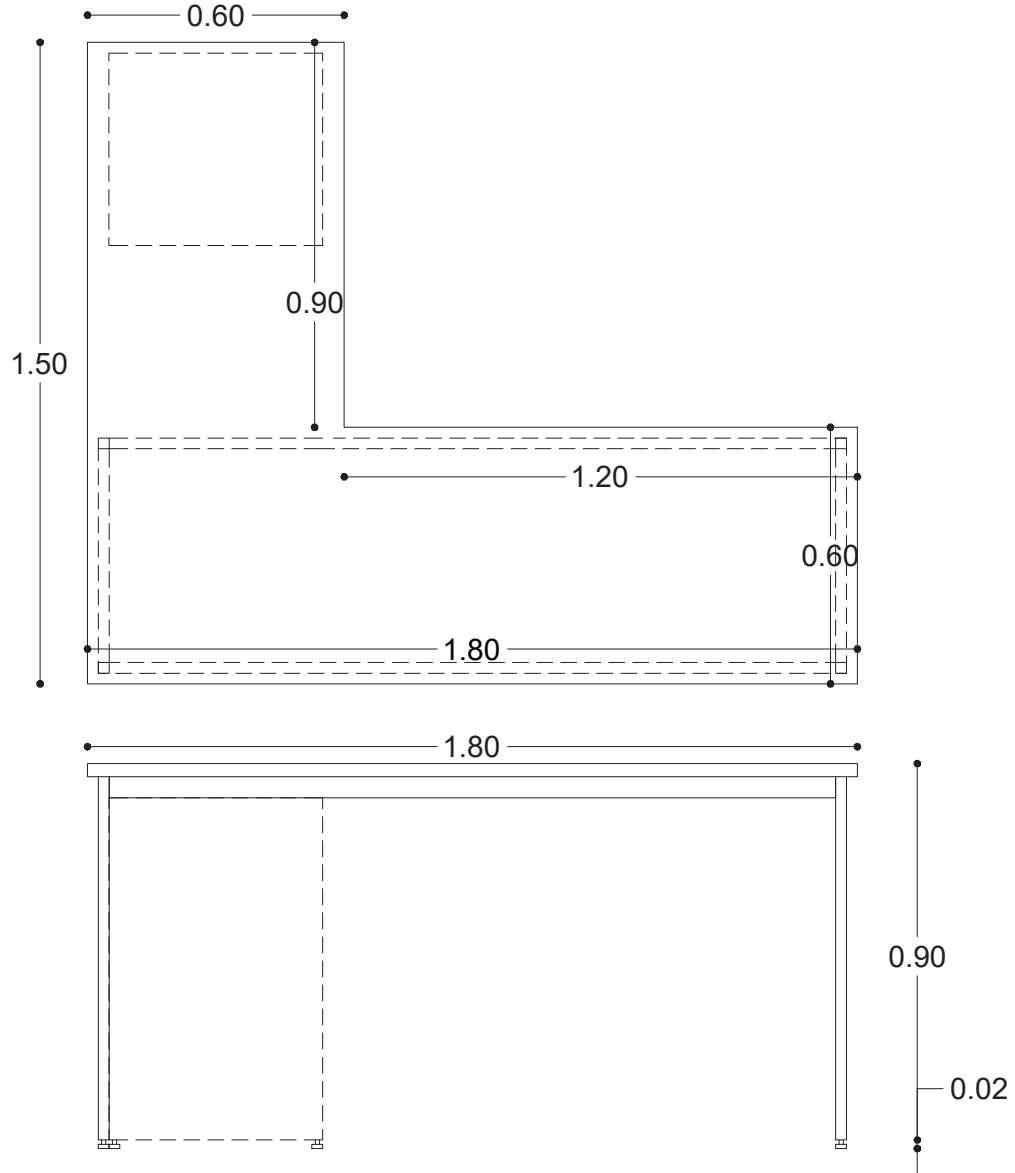

MC 1.140

SOLO ESPECIFICACIÓN TÉCNICA

MC 1.141

SOLO ESPECIFICACIÓN TÉCNICA

MC 1.142

SOLO ESPECIFICACIÓN TÉCNICA

MC 1.143

SOLO ESPECIFICACIÓN TÉCNICA

MC 1.144

SOLO ESPECIFICACIÓN TÉCNICA

MC 1.145

SOLO ESPECIFICACIÓN TÉCNICA

MC 1.146

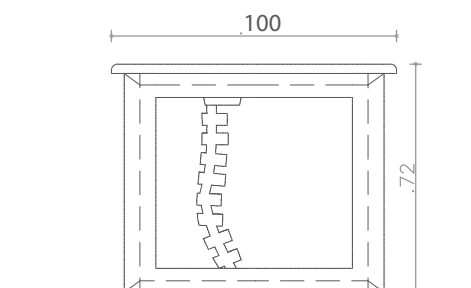
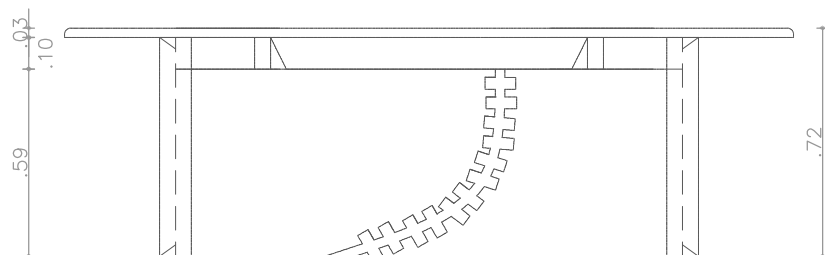
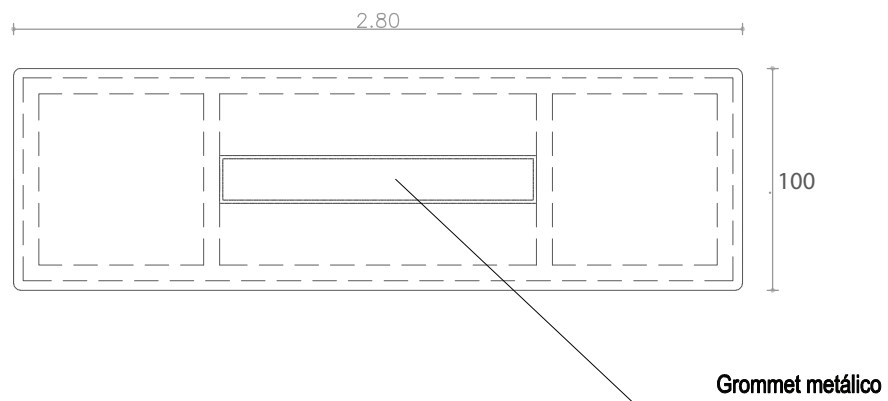

MC 1.147

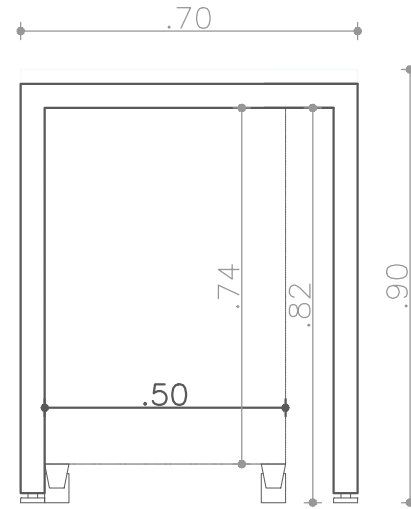
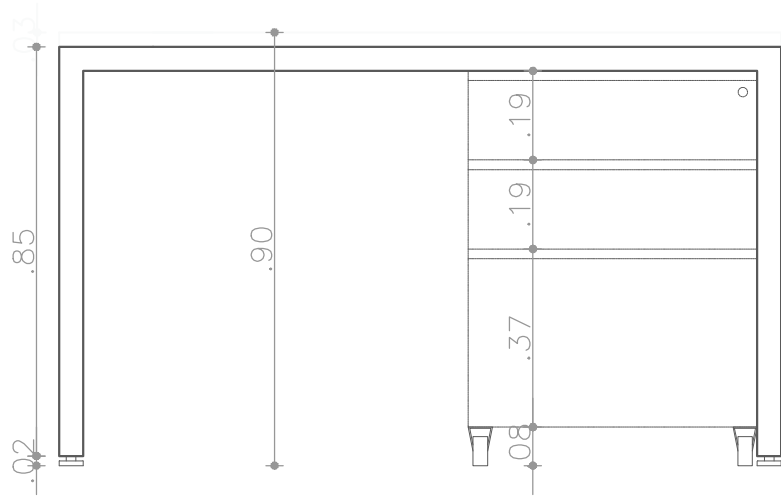
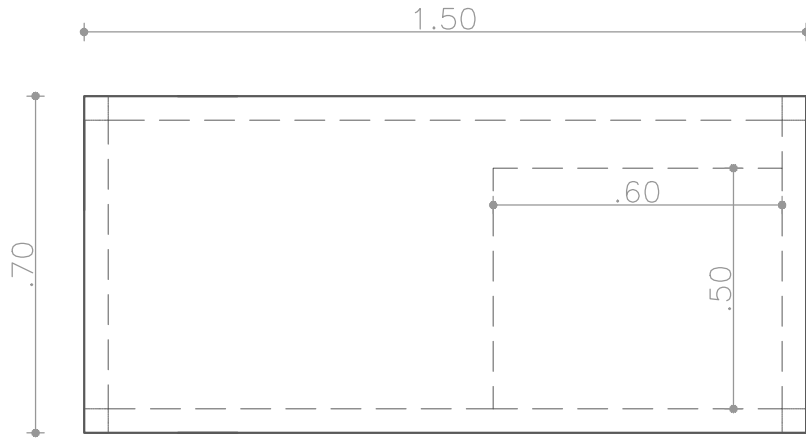

MC 1.148

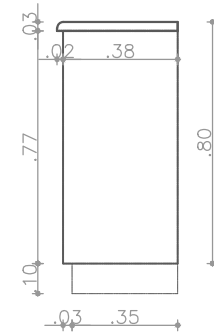
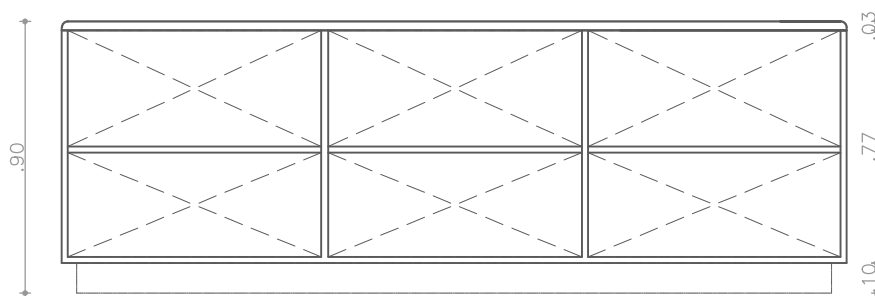
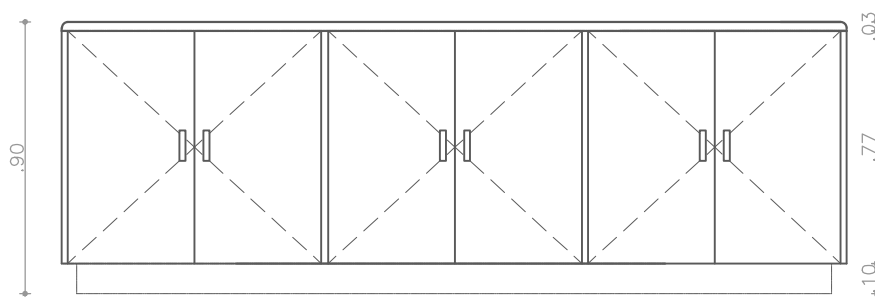

MC 1.149

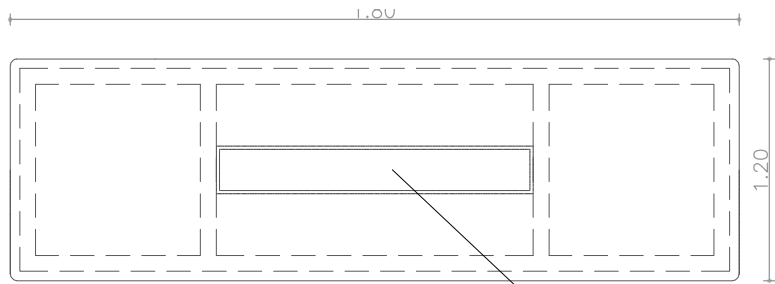

Grommet metálico

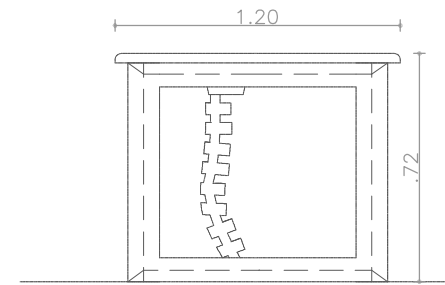
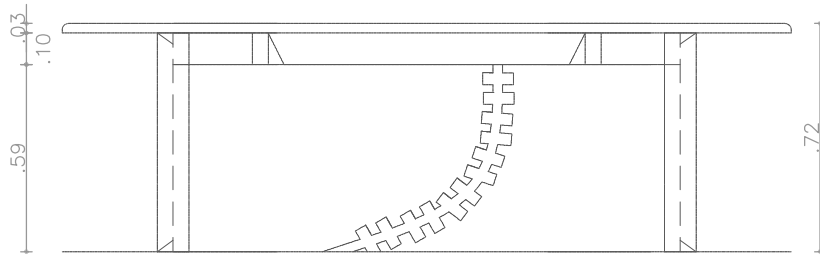

MC 1.150

SOLO ESPECIFICACIÓN TÉCNICA

MC 1.151

SOLO ESPECIFICACIÓN TÉCNICA

MC 1.152

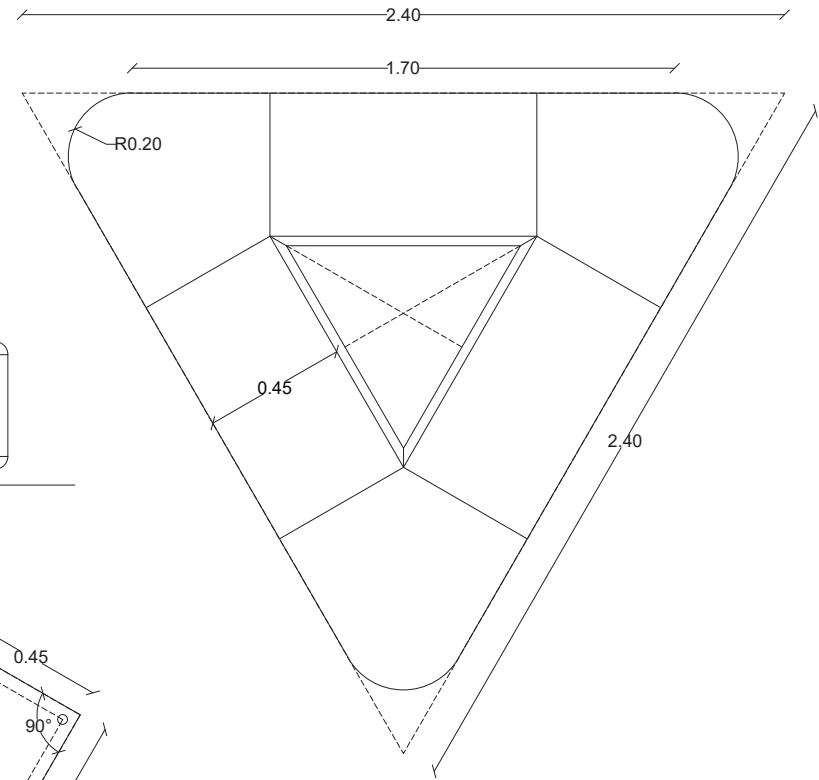
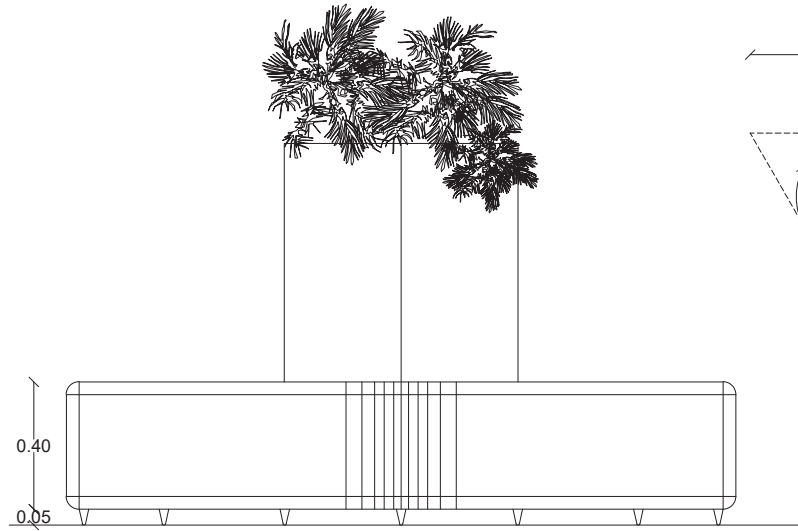

módulo 1

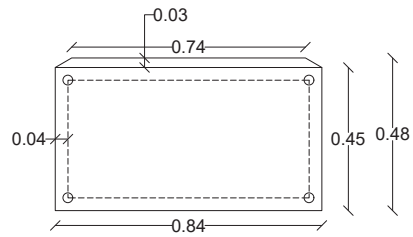

módulo 2

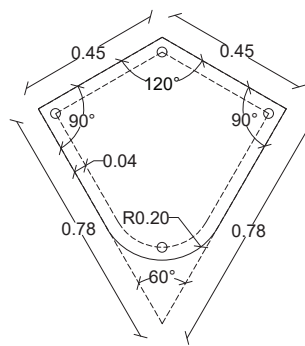

MC 1.153

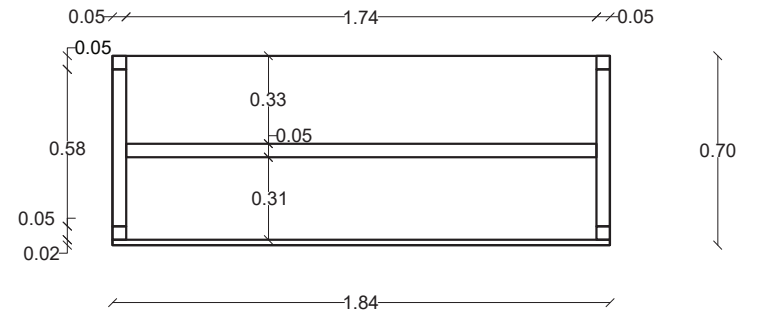
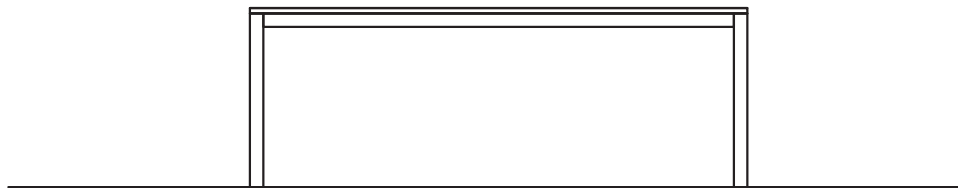
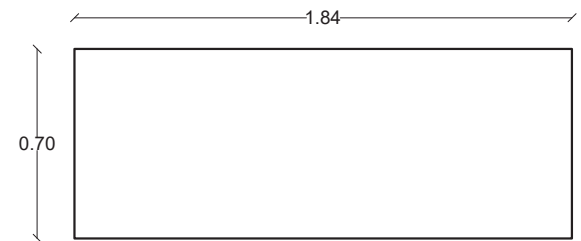
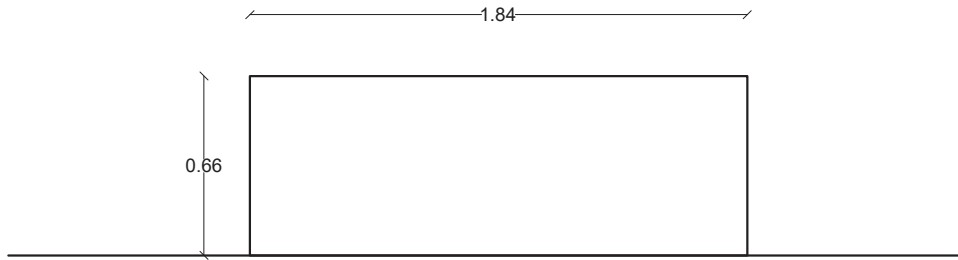
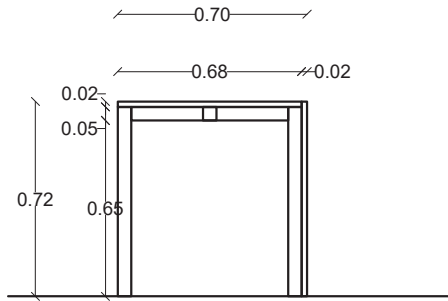

MC 1.154

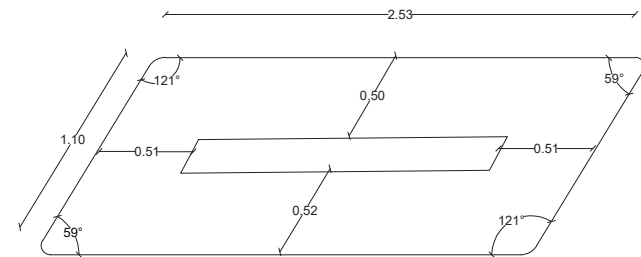
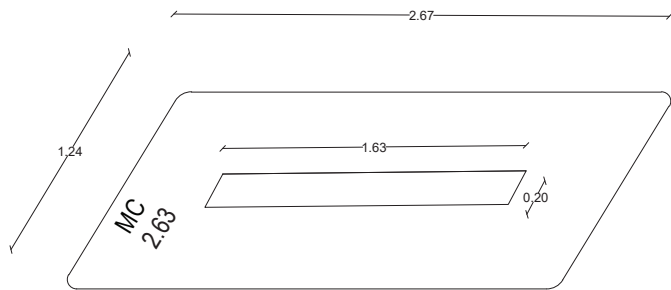
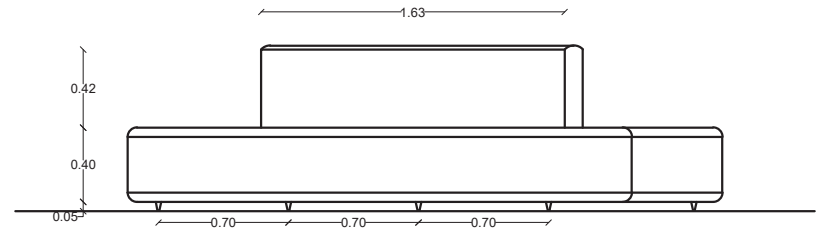
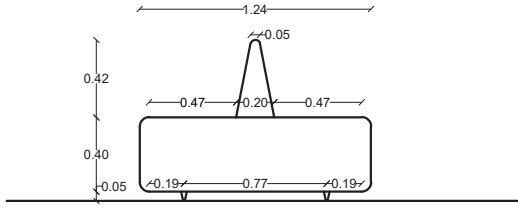

MC 1.155

SOLO ESPECIFICACIÓN TÉCNICA

MC 1.157

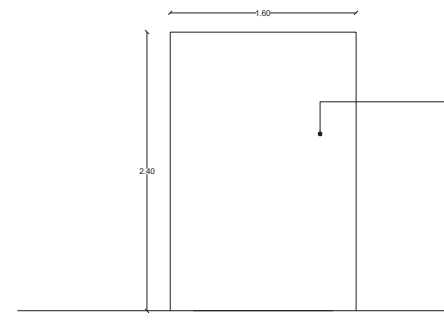
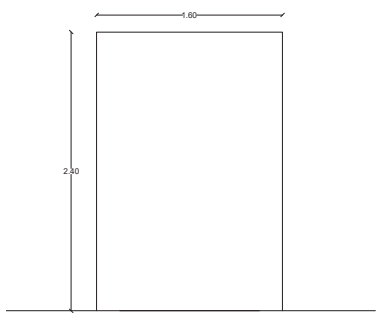
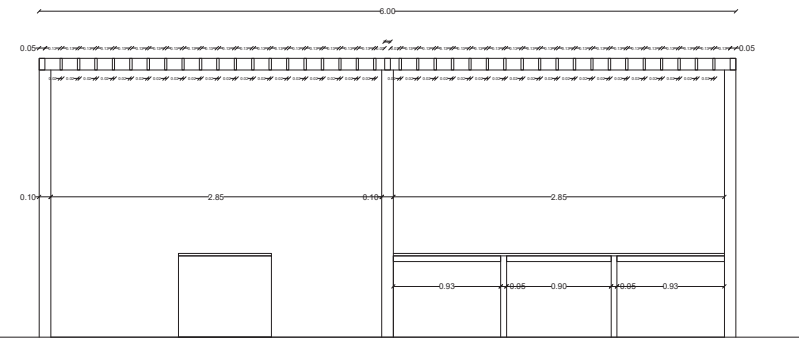
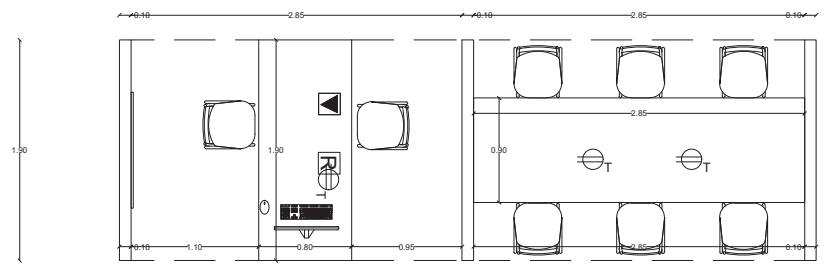
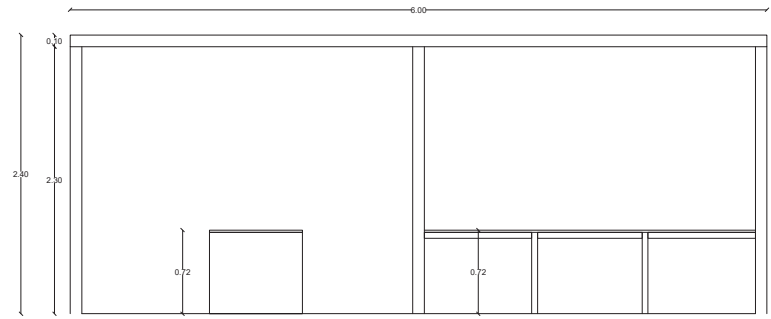
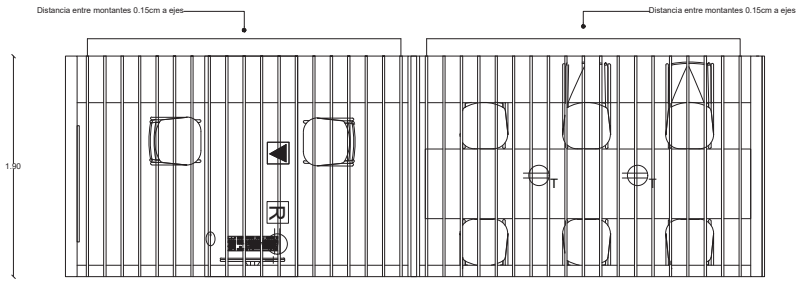

ACABADO EN FÓRMICA ACRÍLICA
PARA ESCRIBIR CON MARCADOR BORRABLE

MC 1.158

SOLO ESPECIFICACIÓN TÉCNICA

MC 1.159

SOLO ESPECIFICACIÓN TÉCNICA

MC 1.160

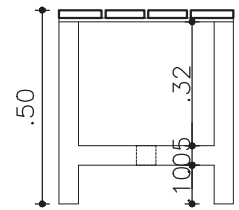
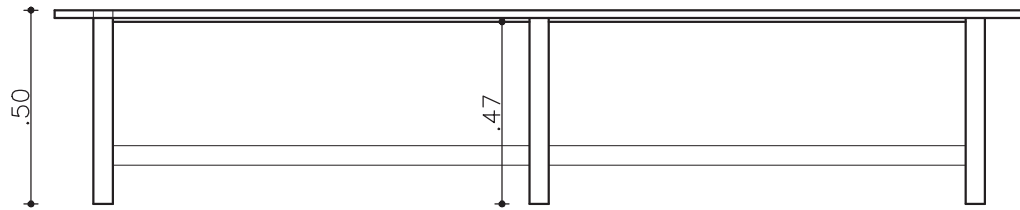
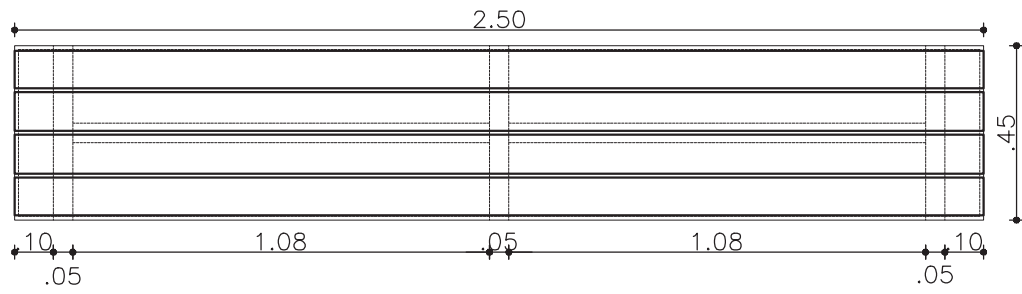

MC 1.161

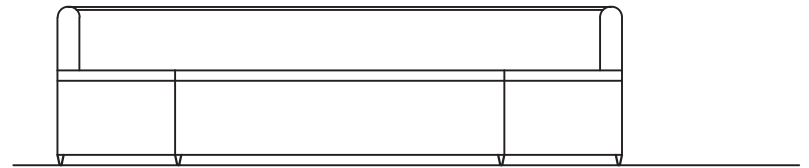
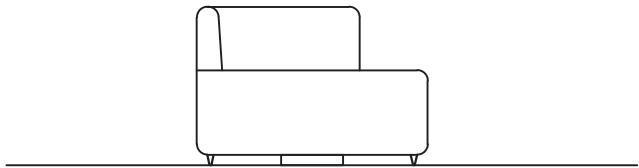
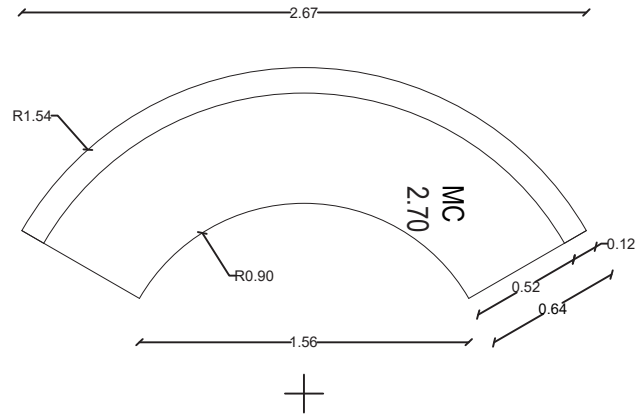

MC 1.162

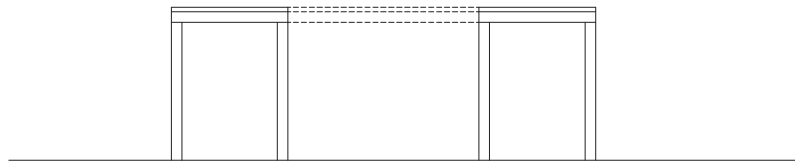
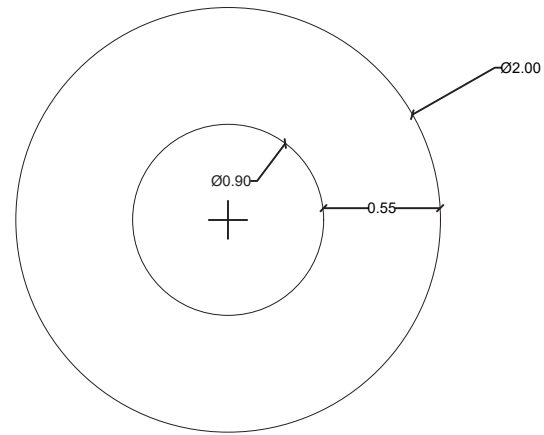
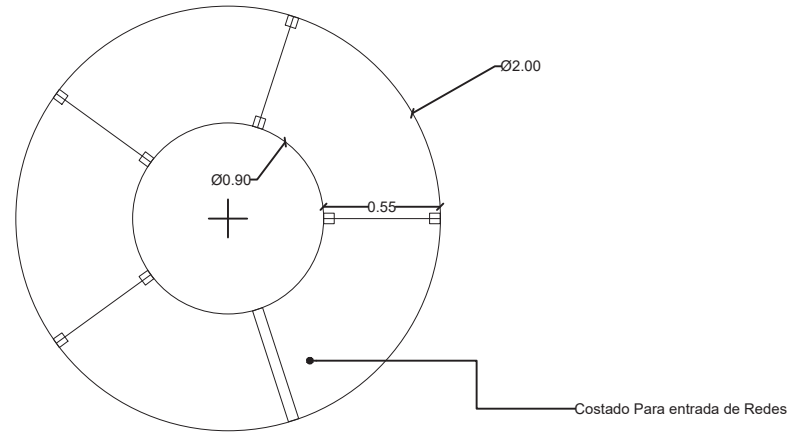

MC 1.163

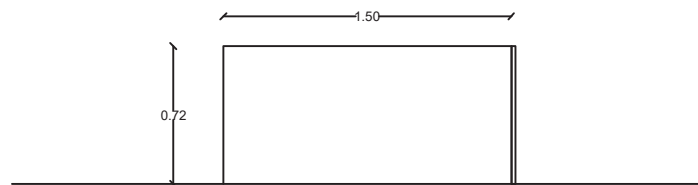
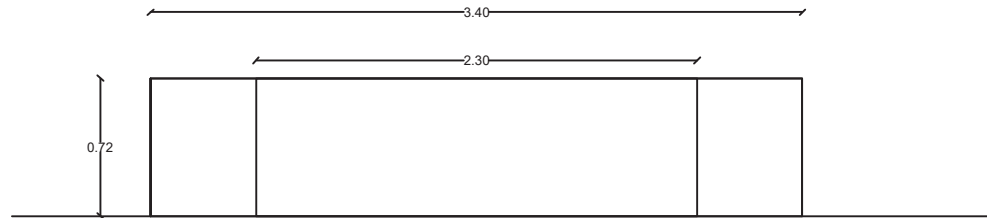
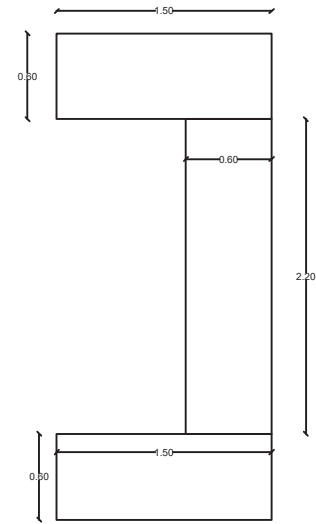
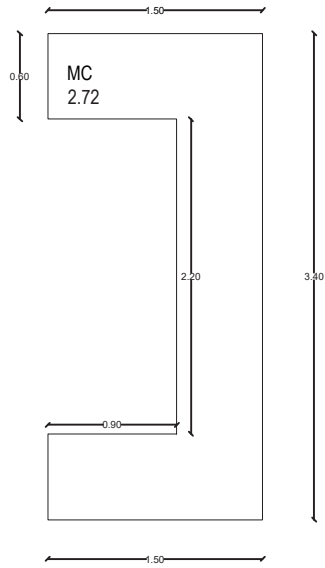

MC 1.164

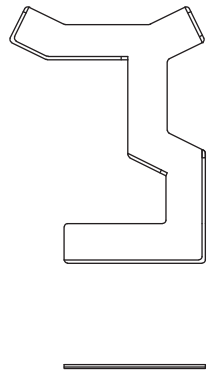
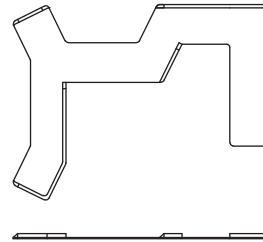
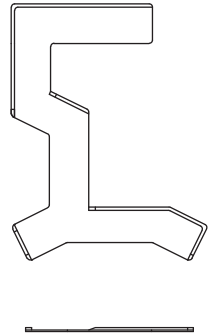
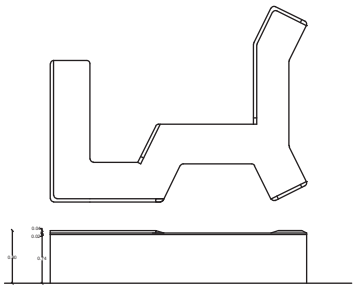
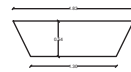
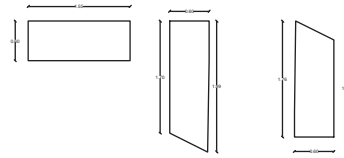
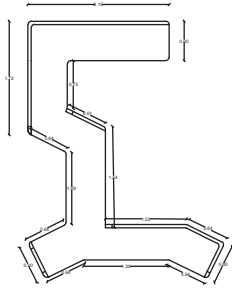

MC 1.165

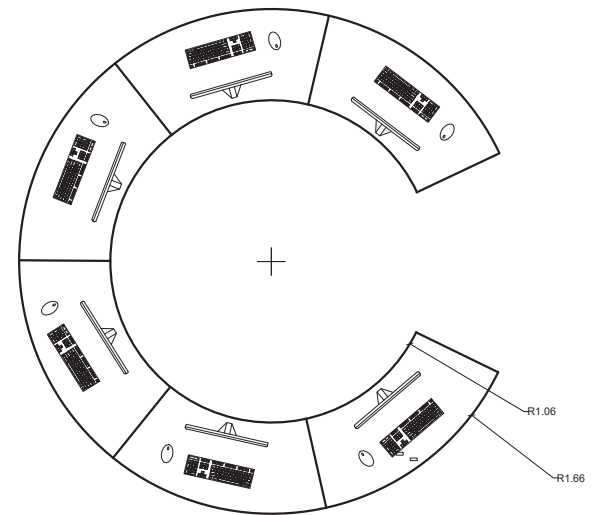
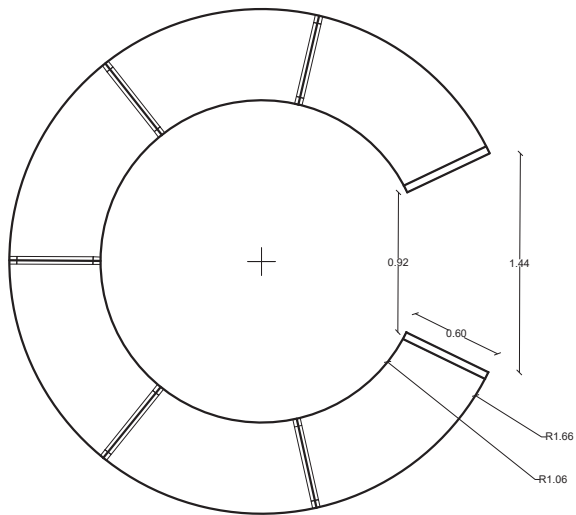
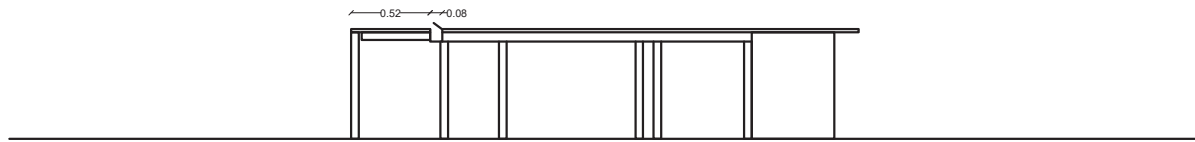
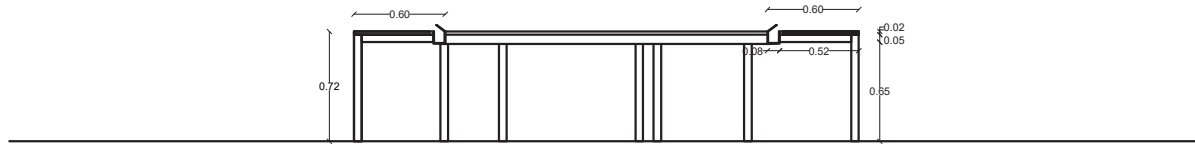

MC 1.166

SOLO ESPECIFICACIÓN TÉCNICA

MC 1.167

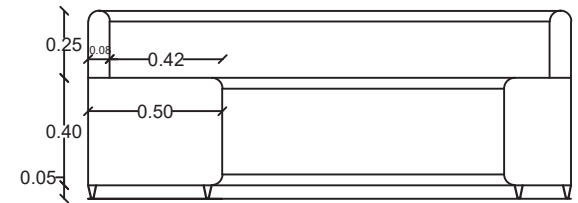
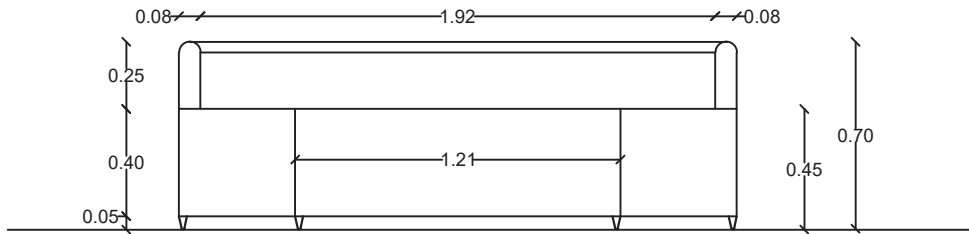
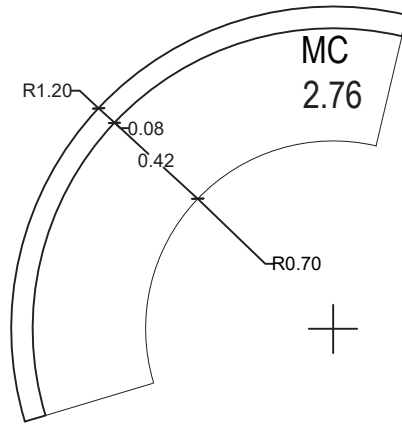

MC 1.168

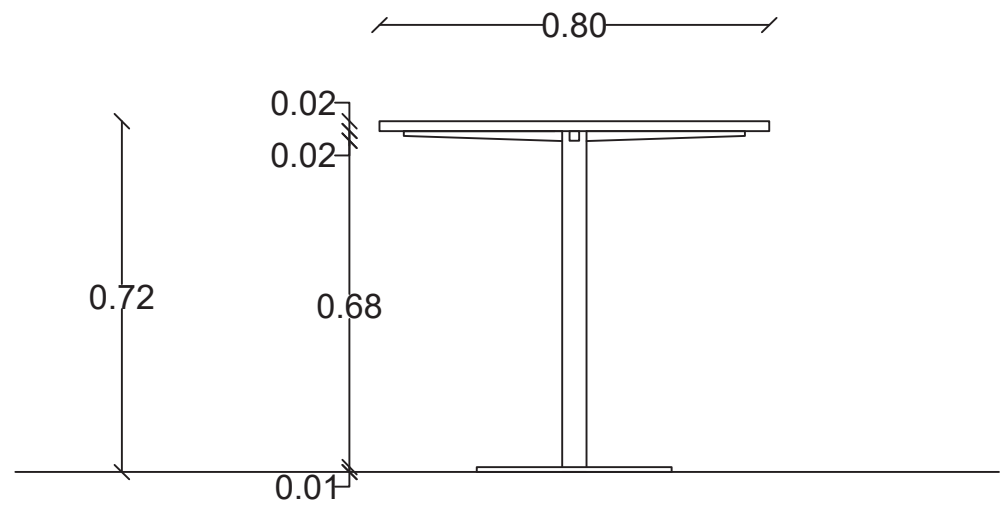
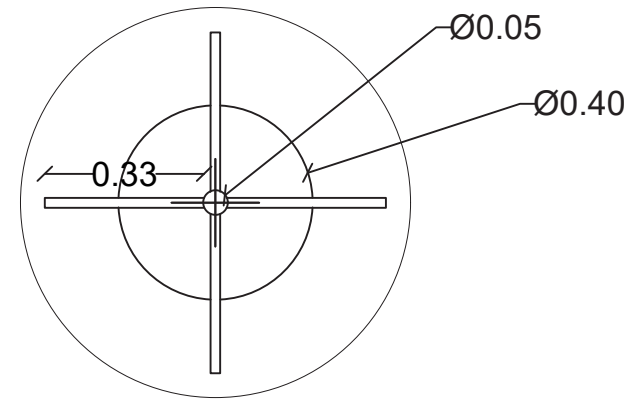
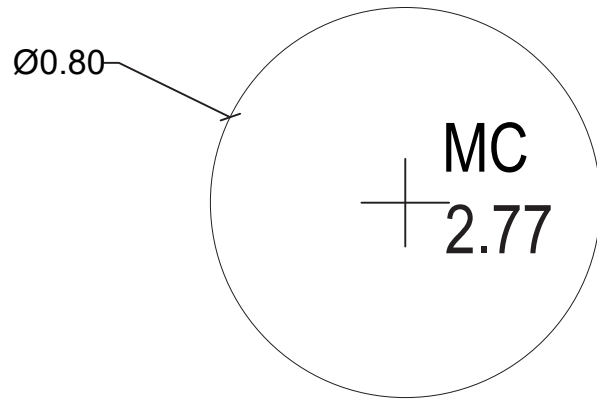

MC 1.169

SOLO ESPECIFICACIÓN TÉCNICA

MC 1.170

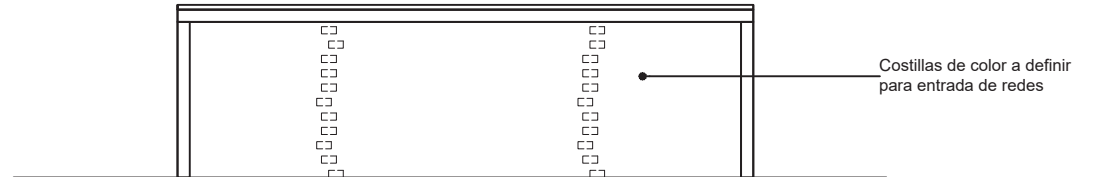
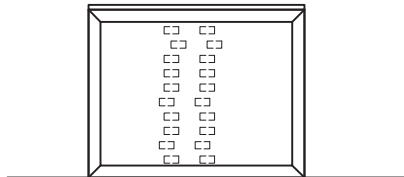
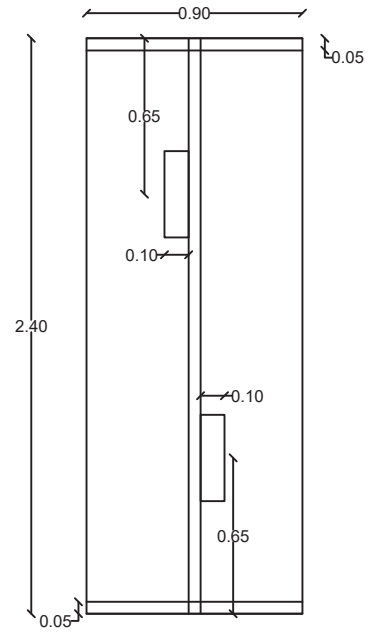
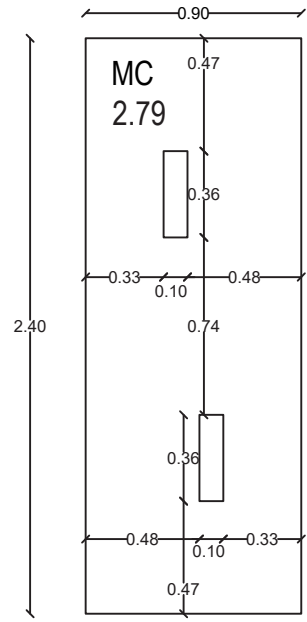

MC 1.171

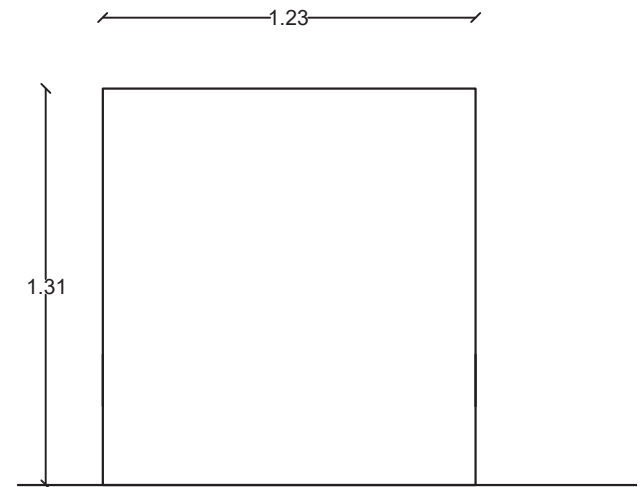
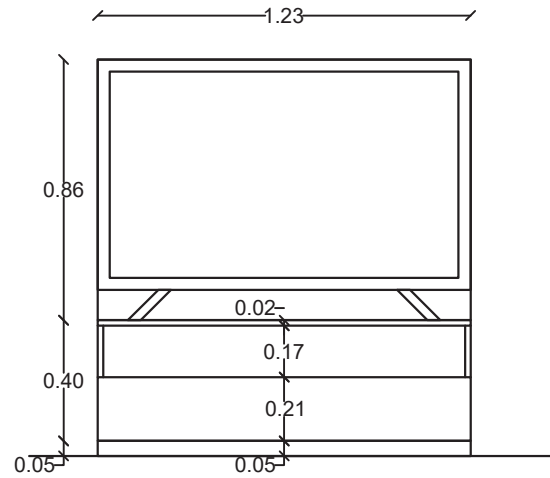
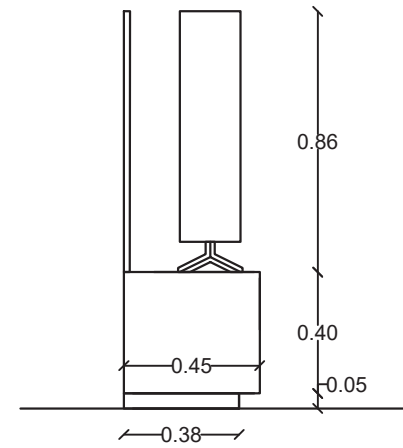
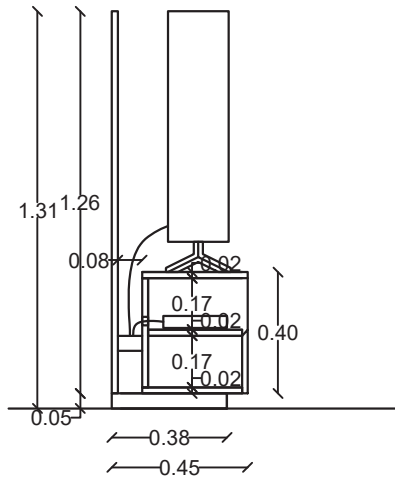
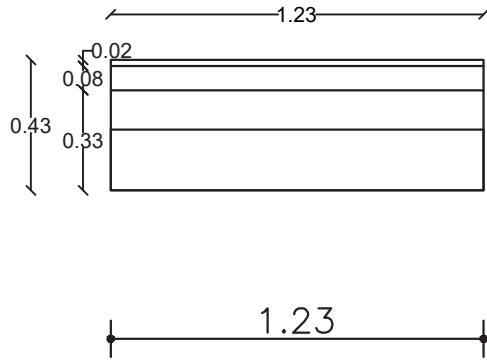

MC 1.172

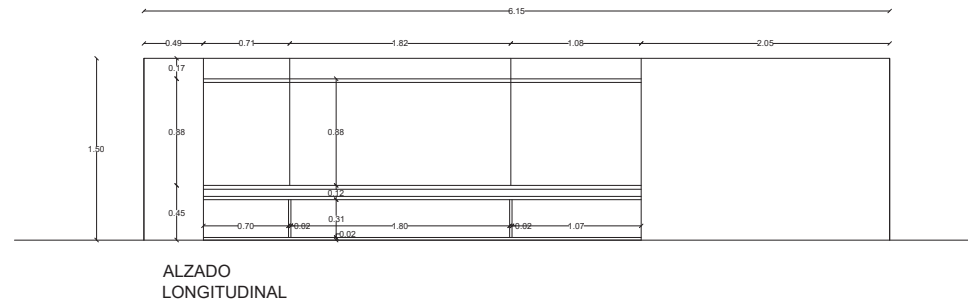
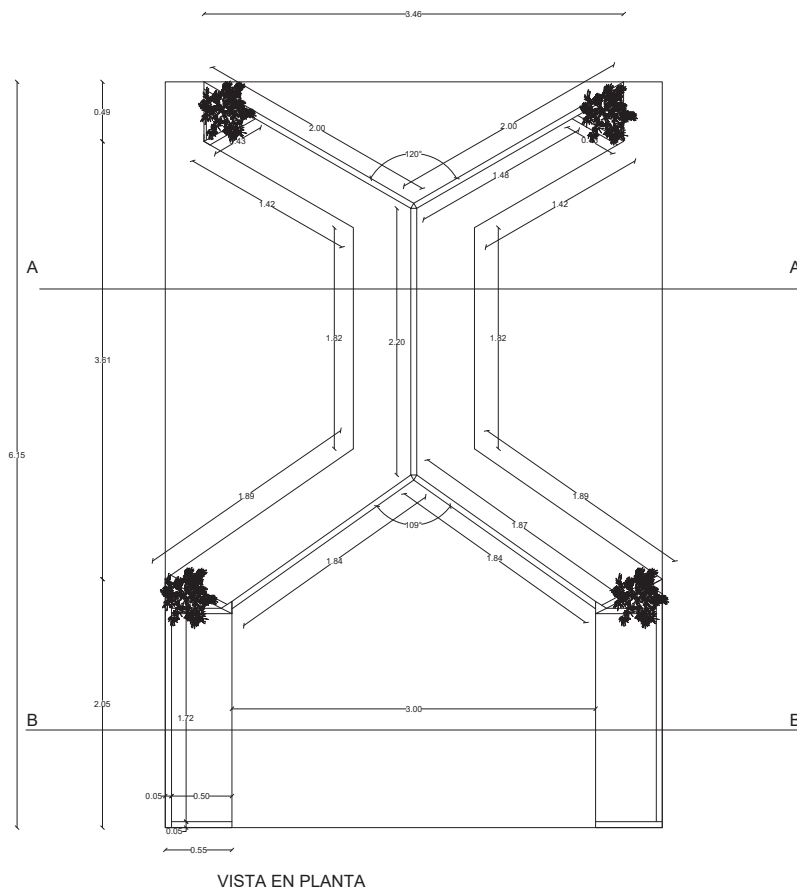
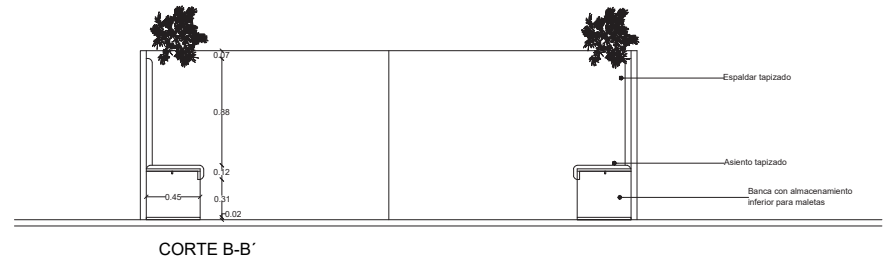
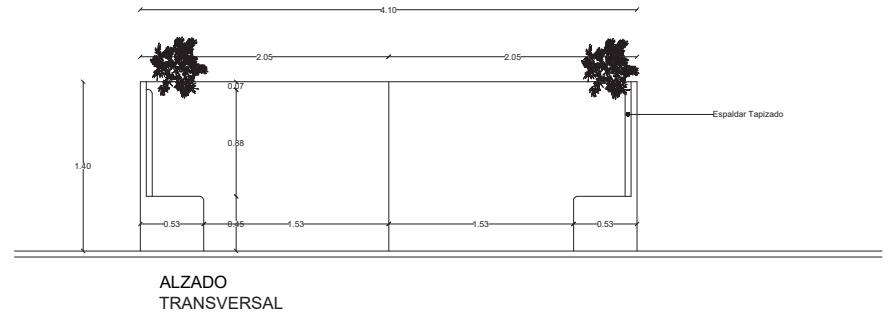
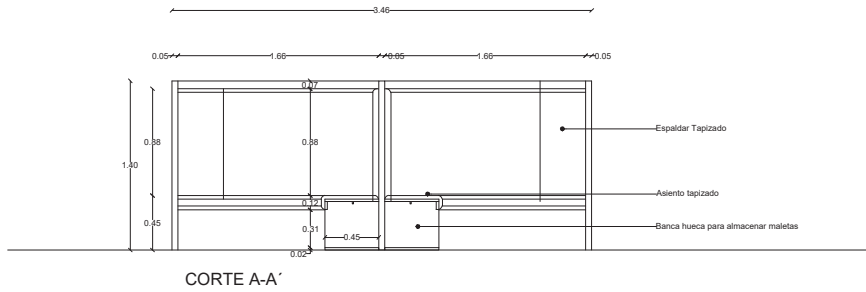

MC 1.173

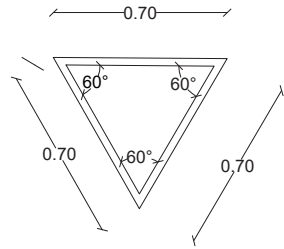

Planta

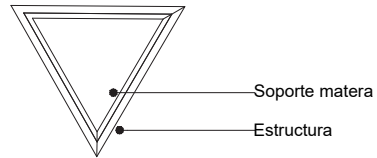

Planta

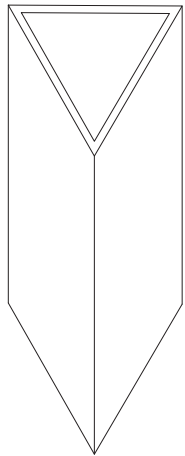

Vista en axonometría

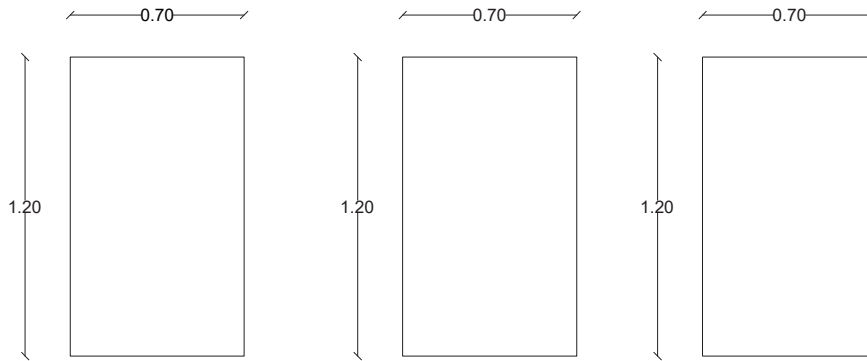

Alzados

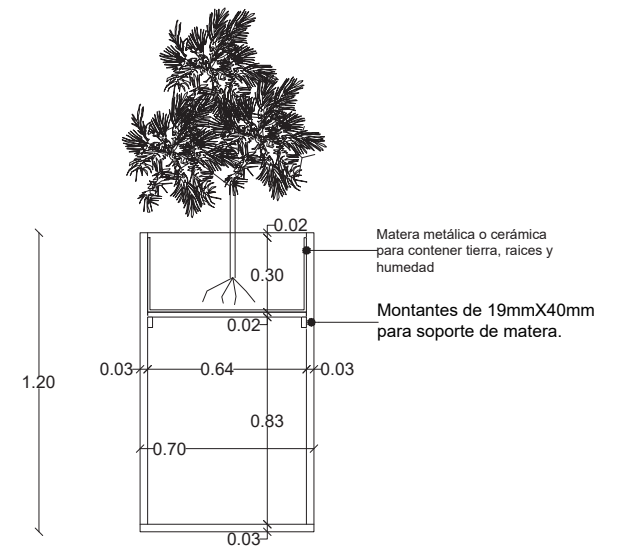

Corte

MC 1.174

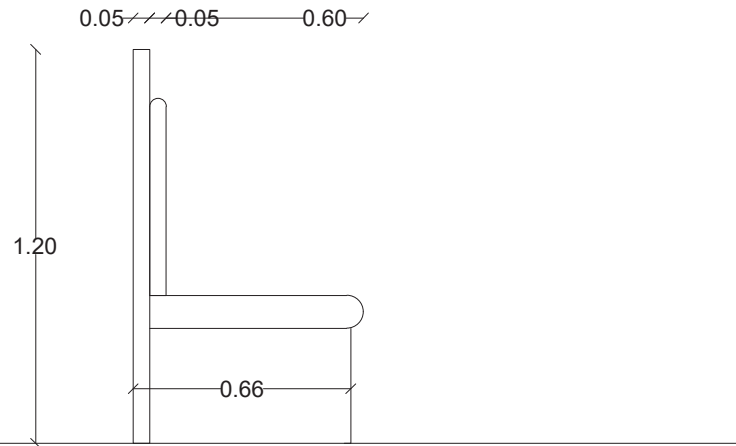

ALZADO LATERAL

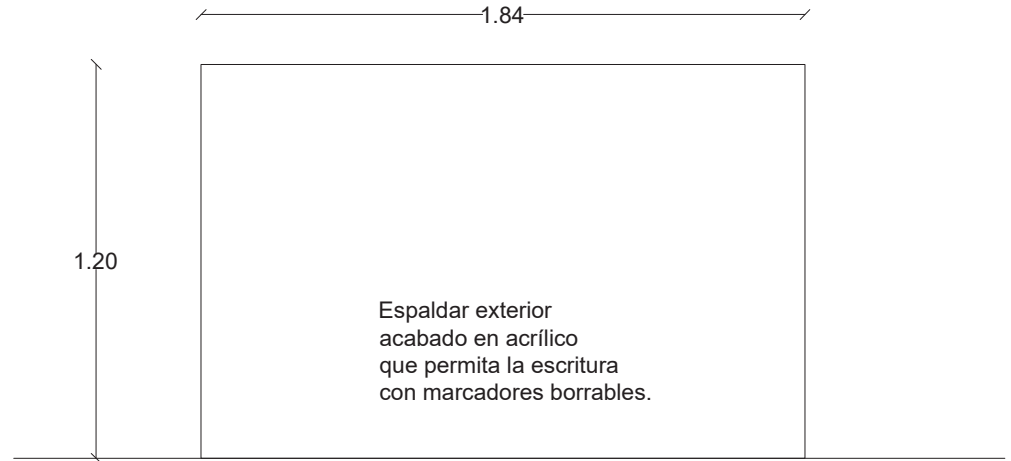

ALZADO POSTERIOR

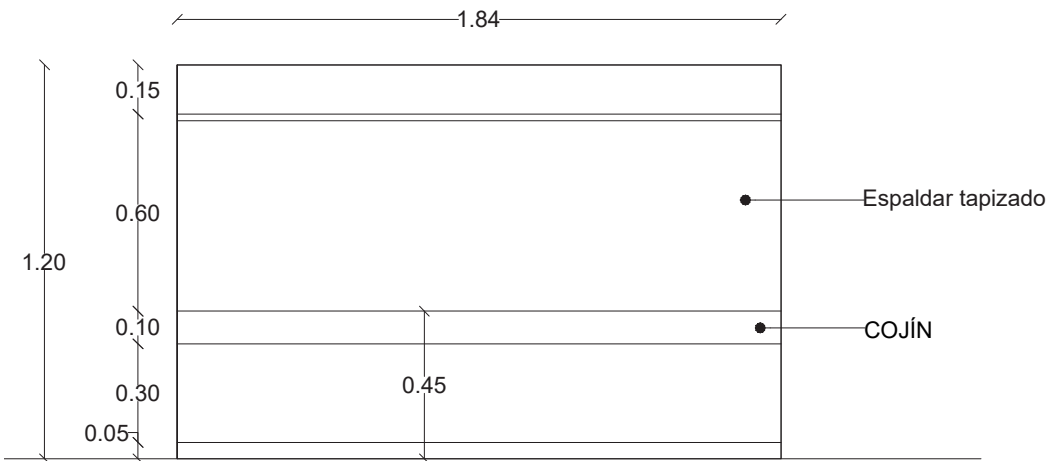

ALZADO FRONTAL

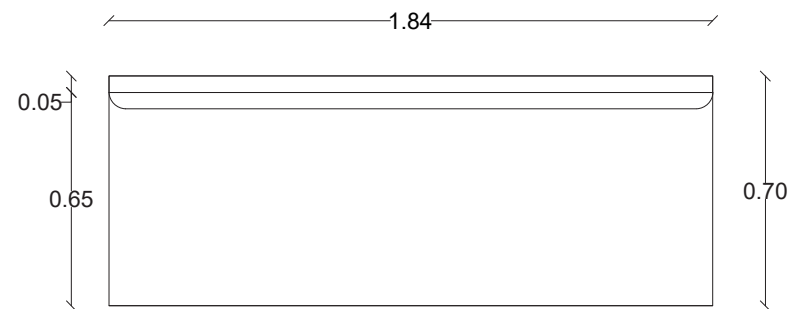

VISTA EN PLANTA

MC 1.175

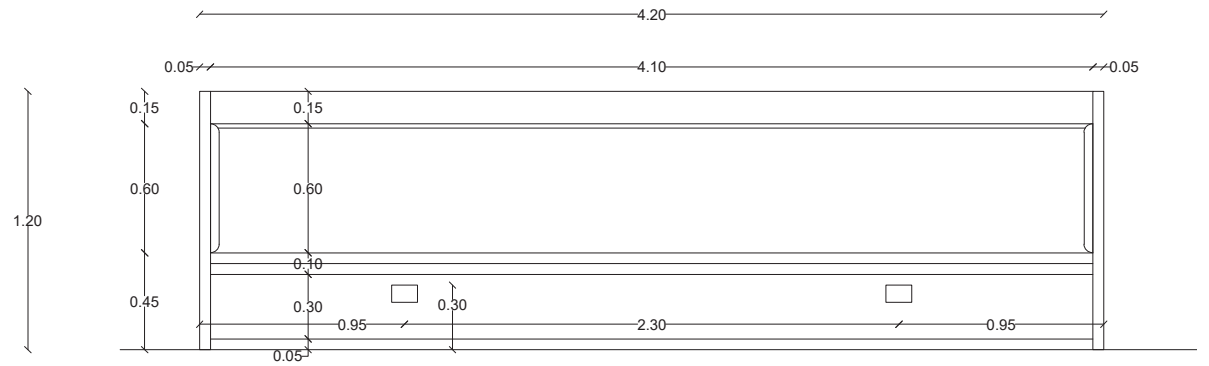
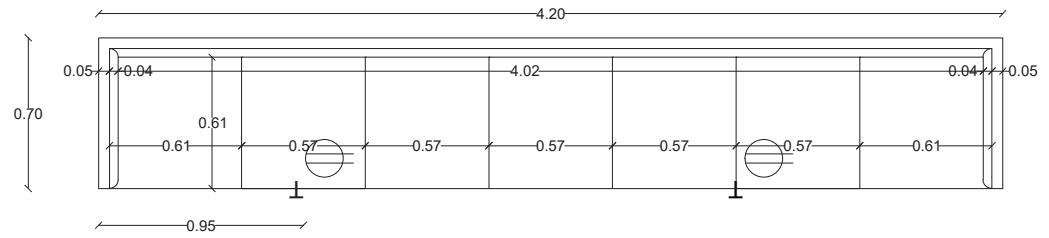
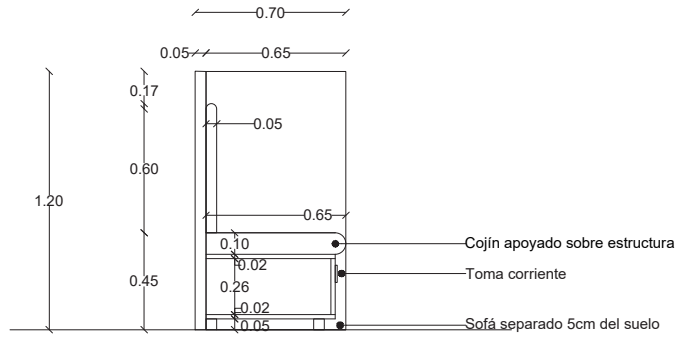

MC 1.176

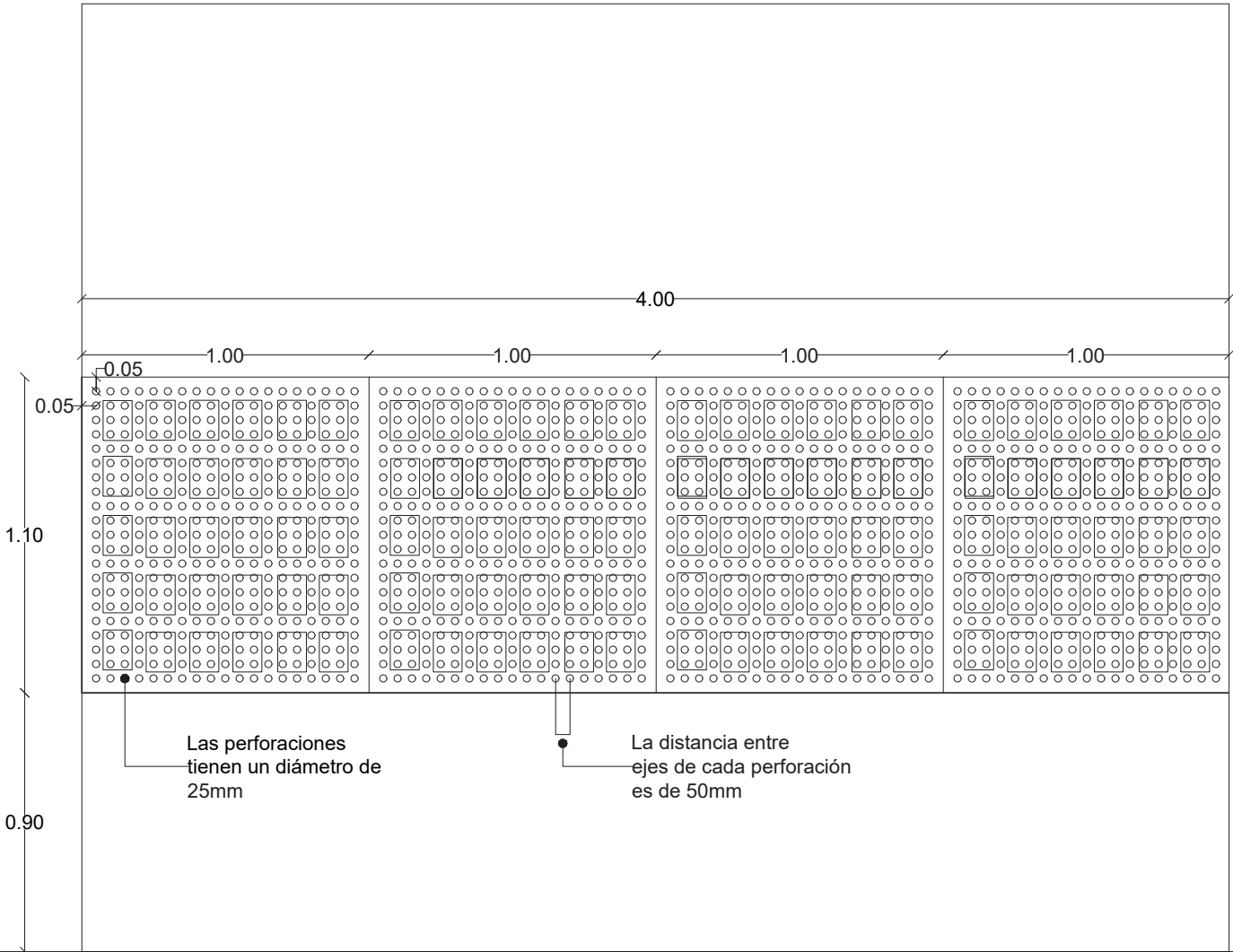
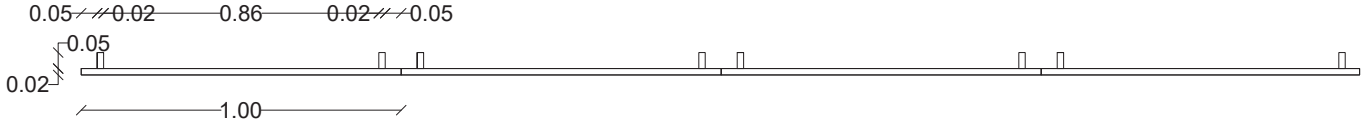

MC 1.177

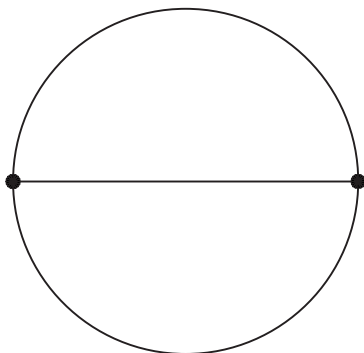

$\varnothing.60$

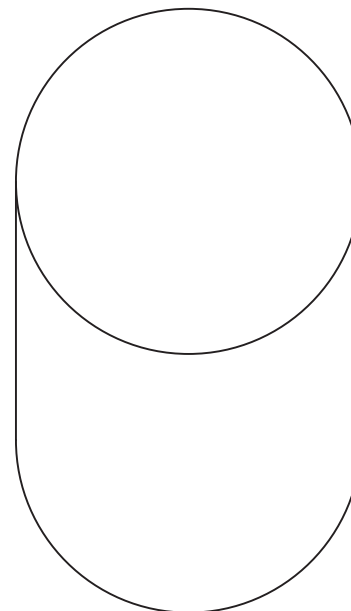

0.60

0.45



MC 1.178

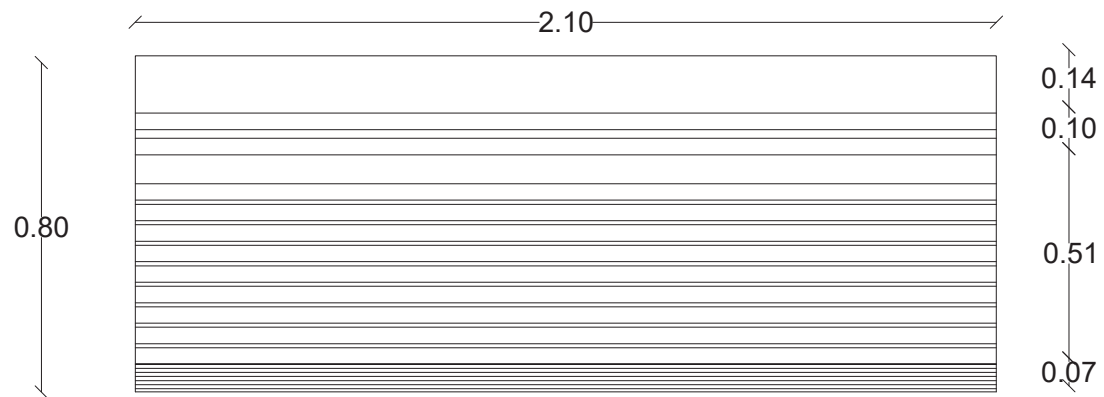

Vista en Planta ■

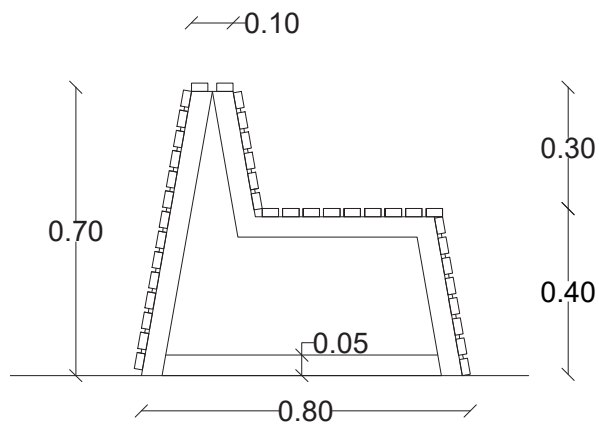

Corte

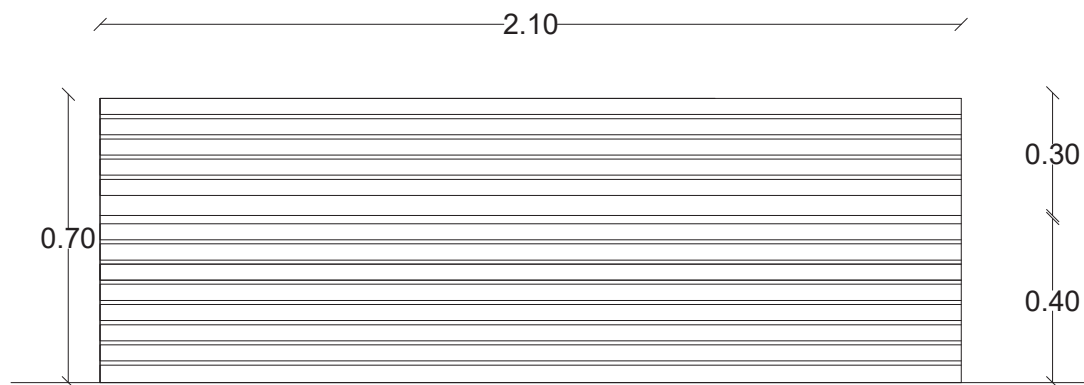

Alzado

MC 1.179

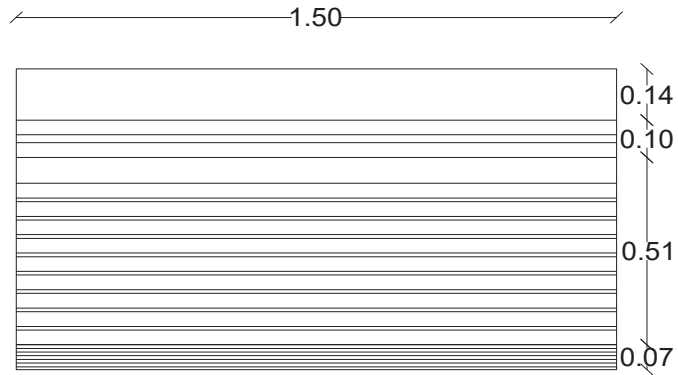

Vista en Planta ■

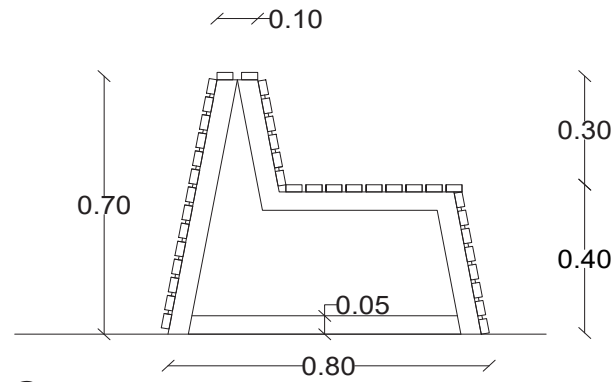

Corte

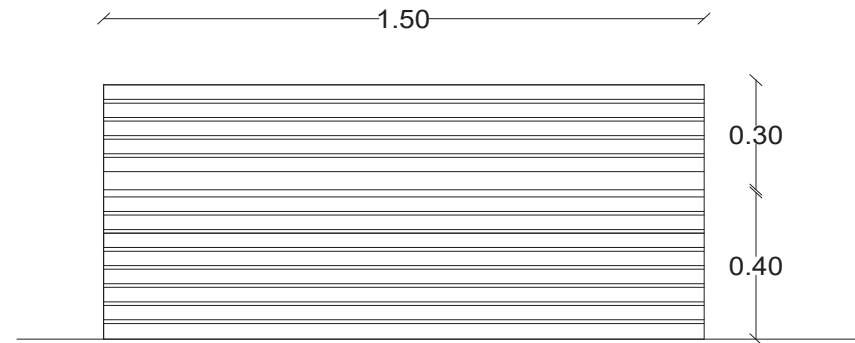

Alzado

MC 1.180

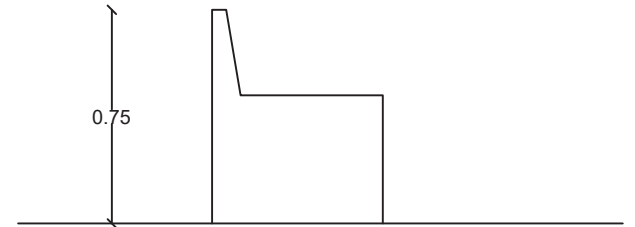
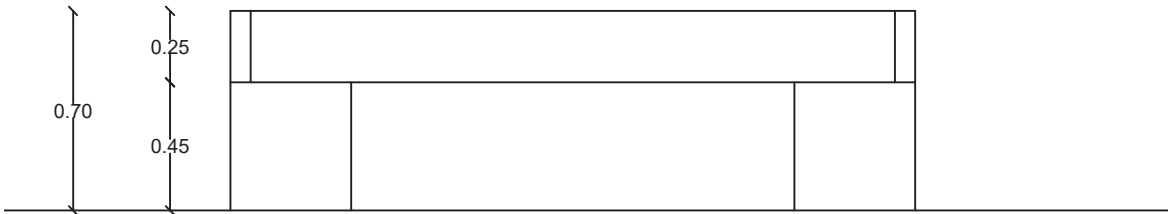
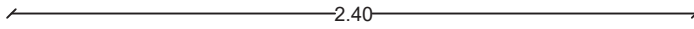
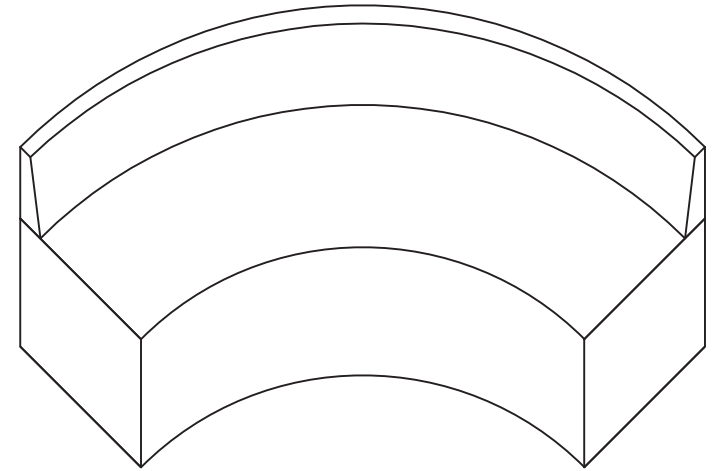
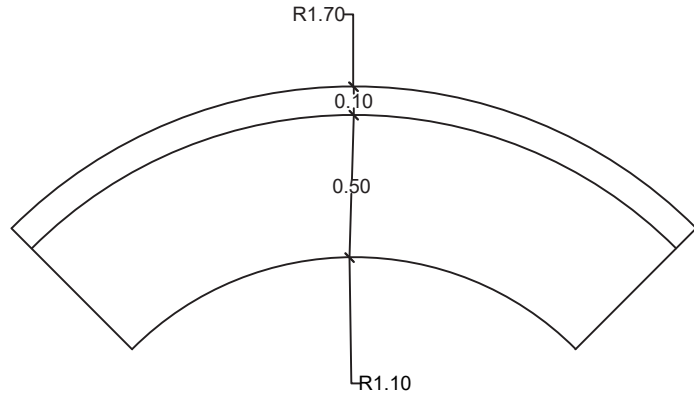

MC 1.181

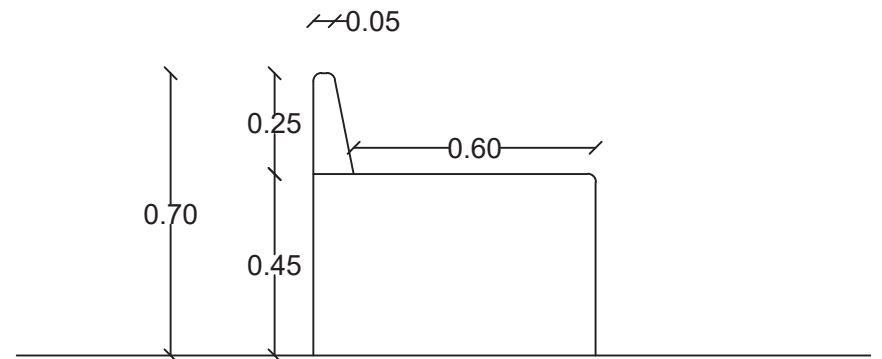
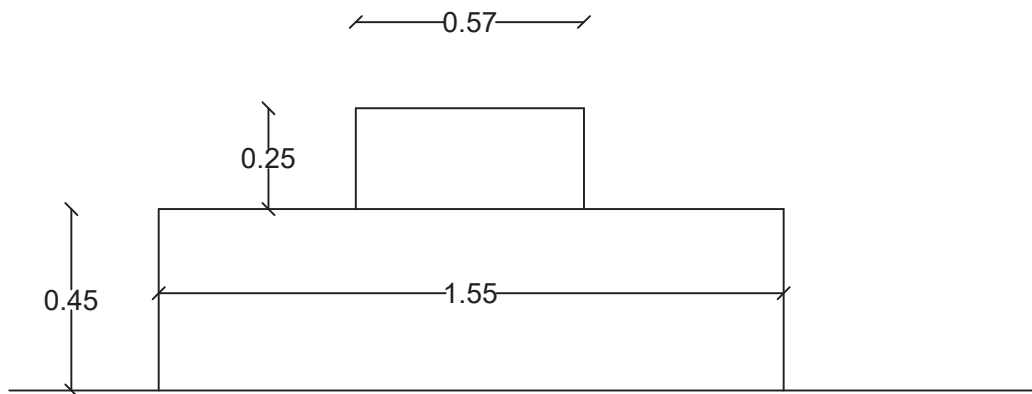
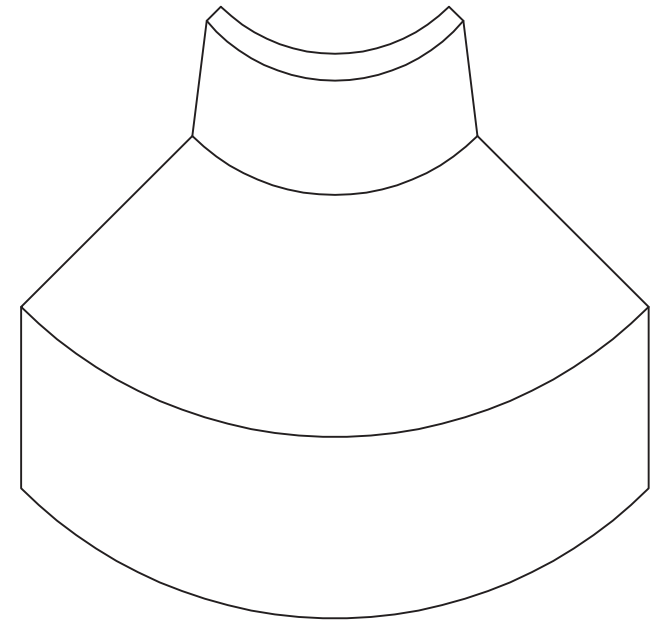
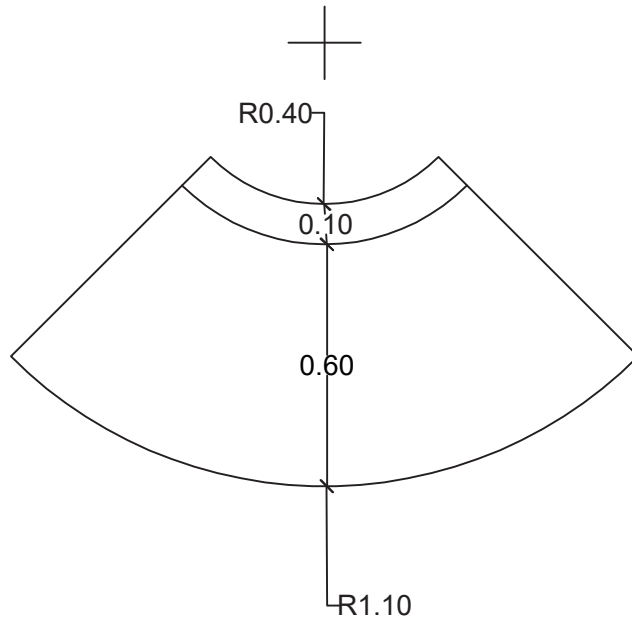

MC 1.182

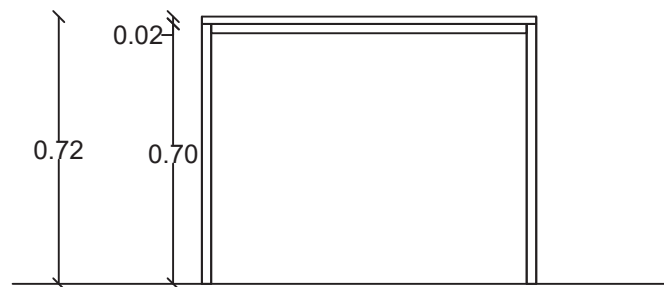
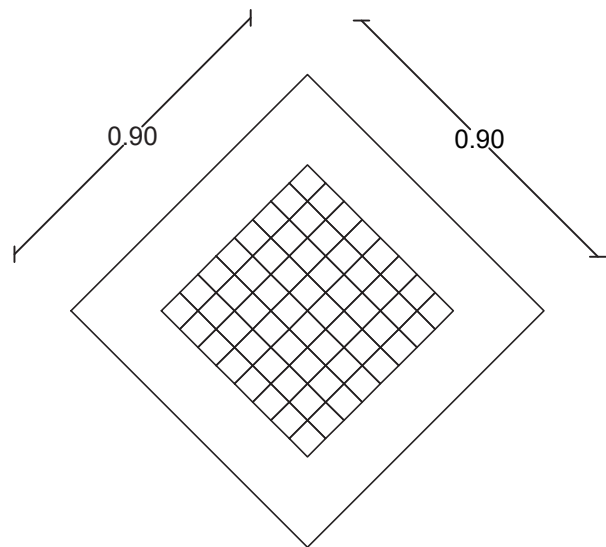

MC 1.183

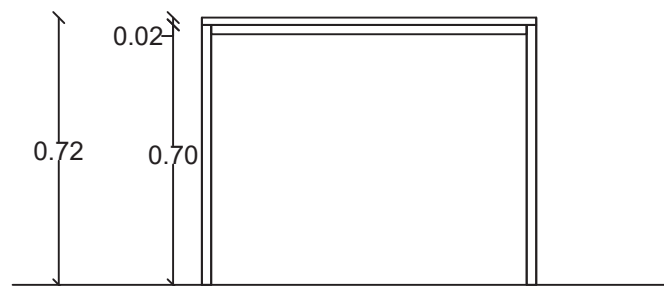
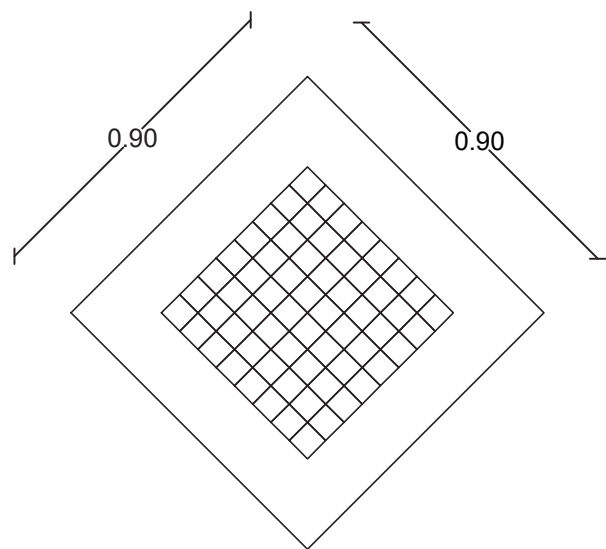

MC 1.184

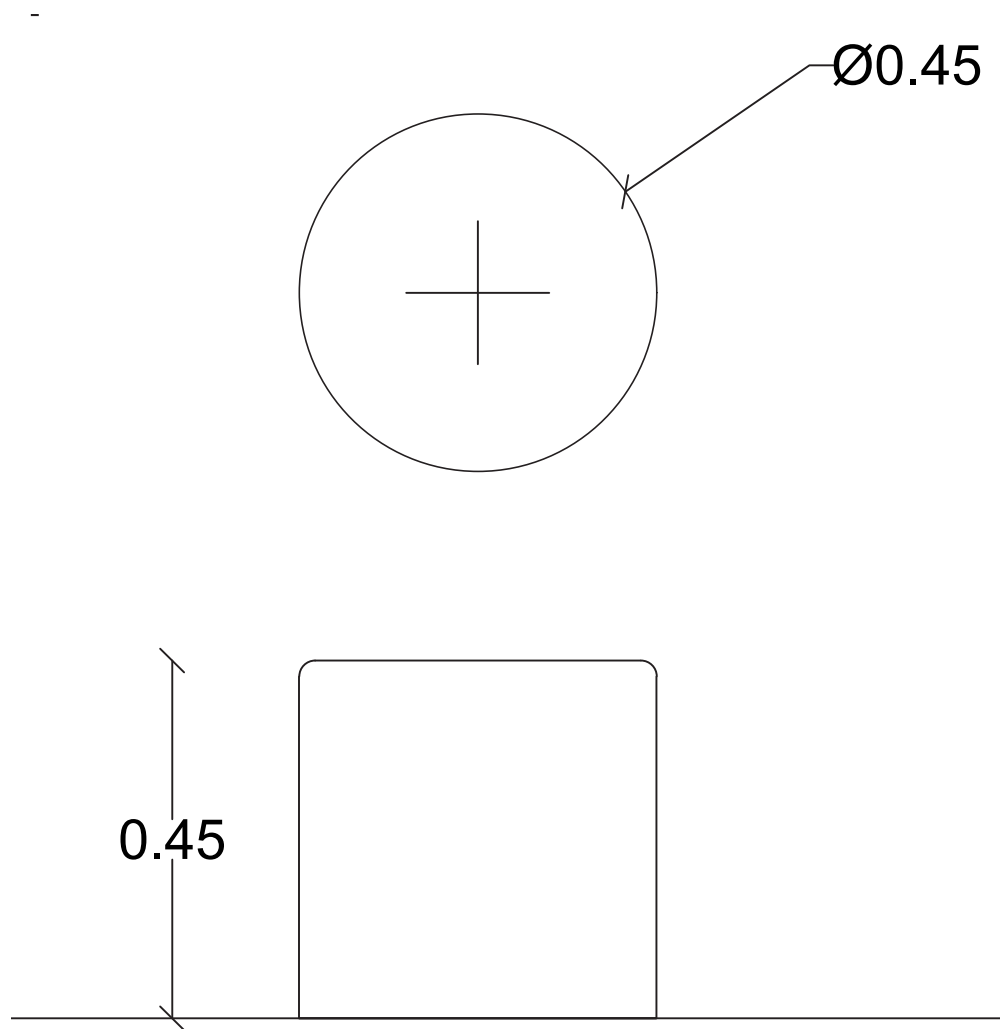

MC 1.185

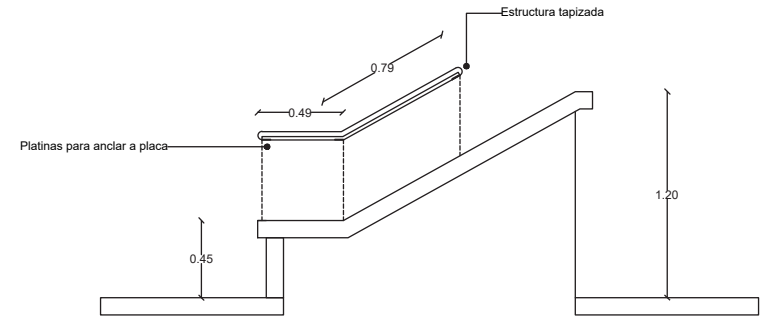
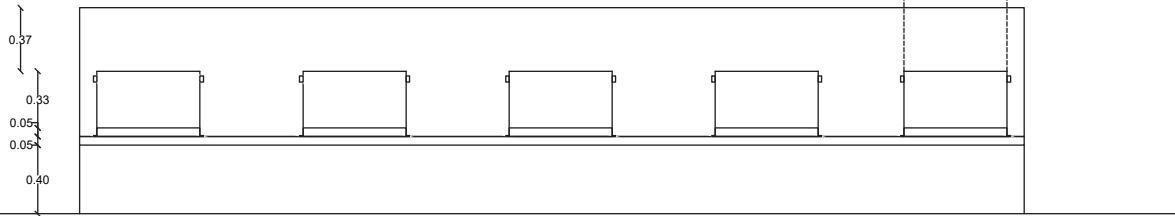
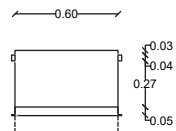
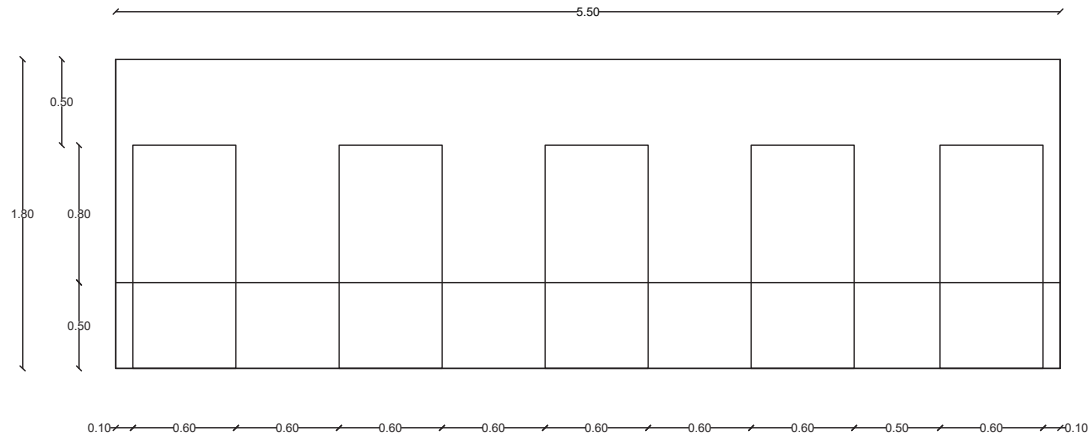

MC 1.186

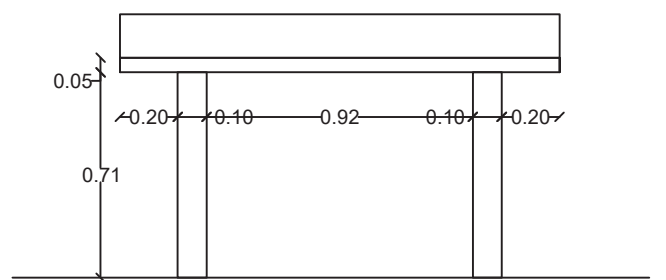
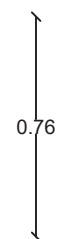
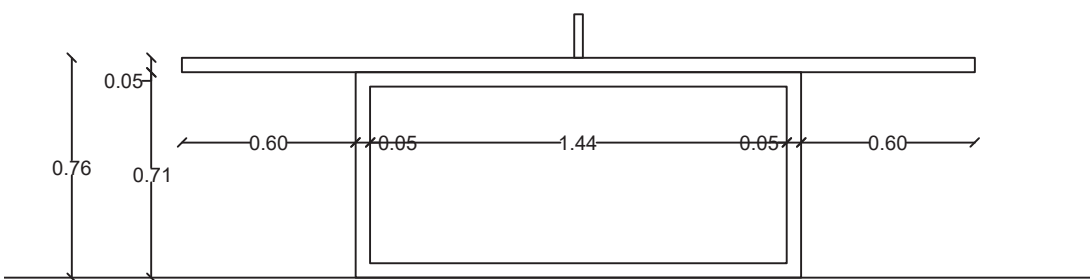
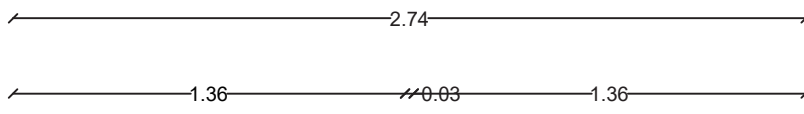
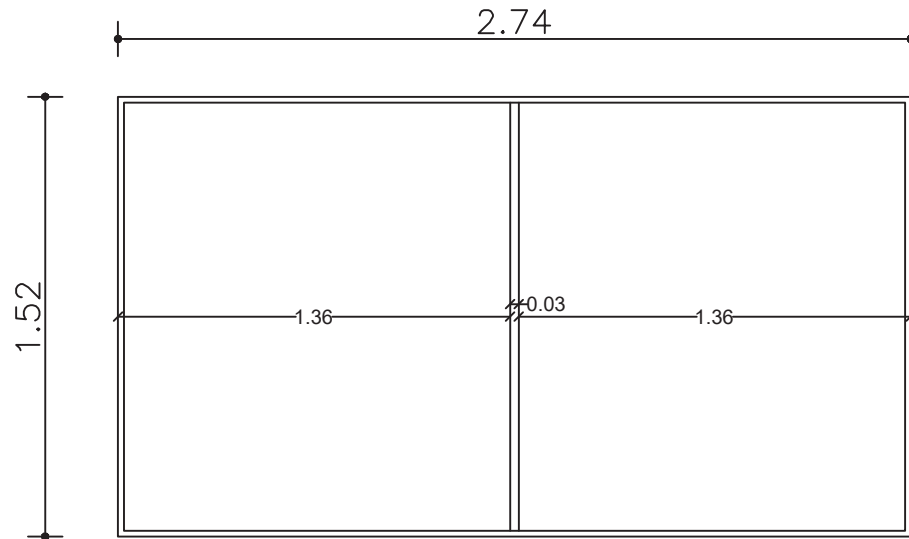

MC 1.187

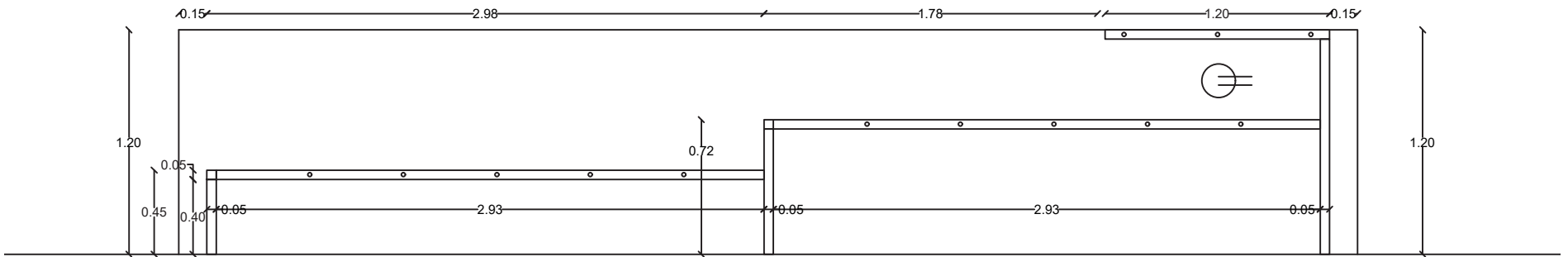
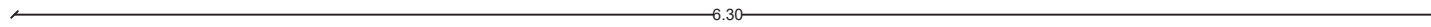
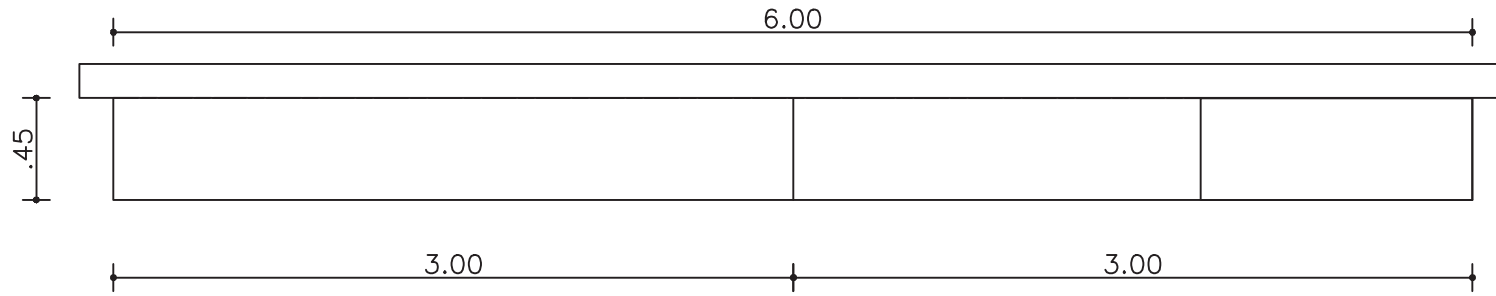

MC 1.188

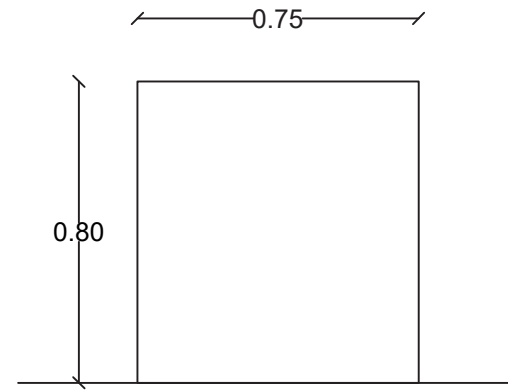
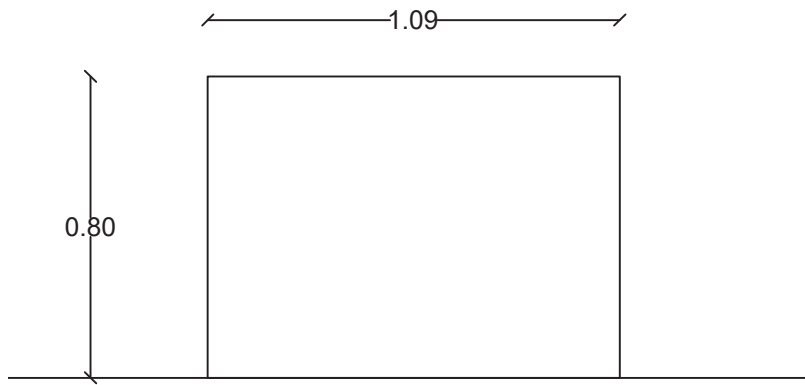
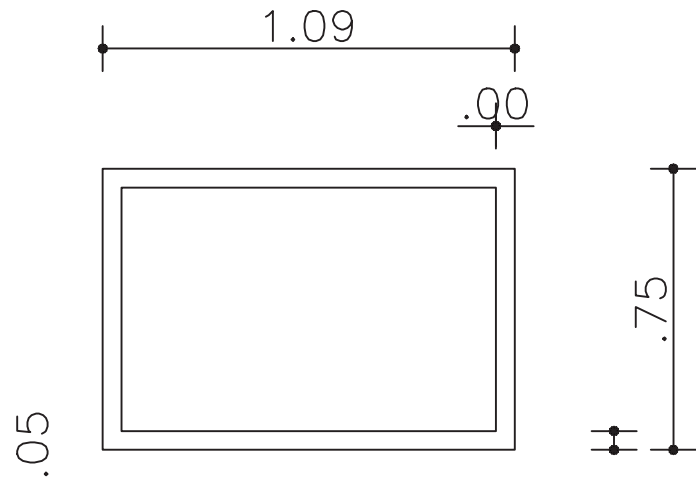

MC 1.189

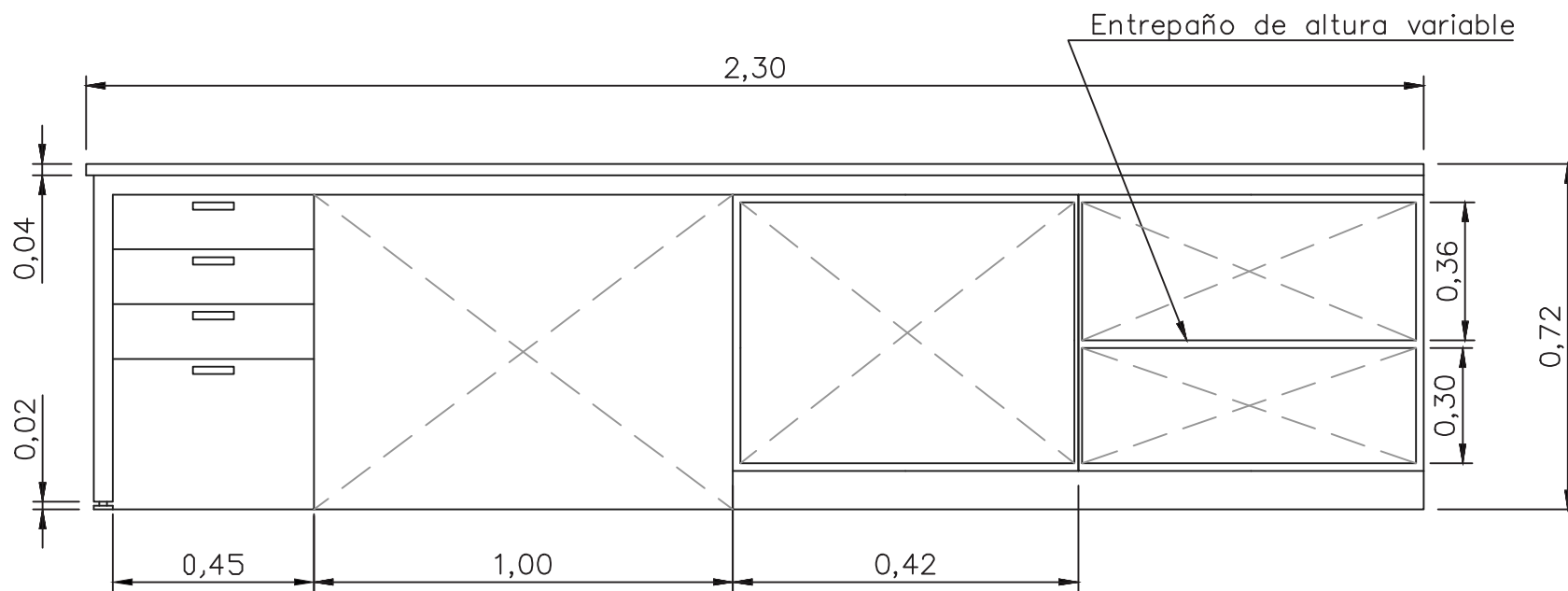
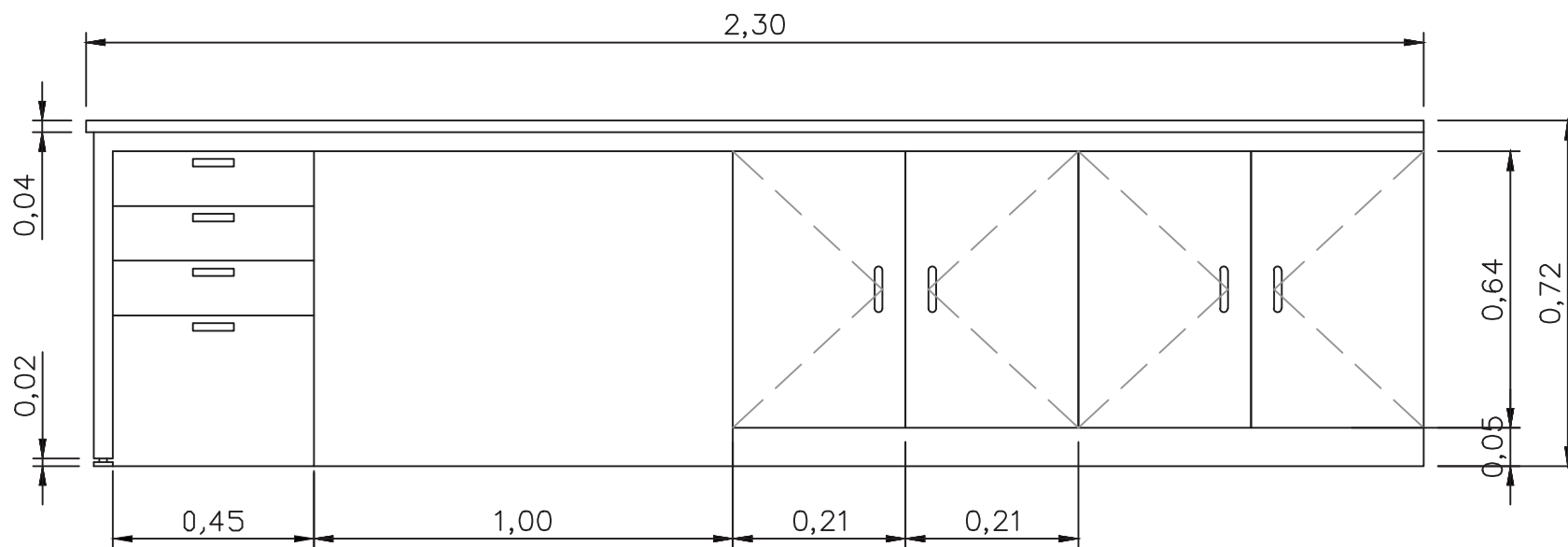

MC 1.190

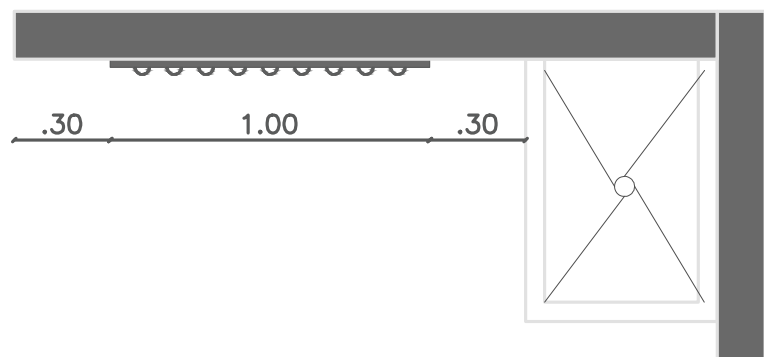

VISTA EN PLANTA

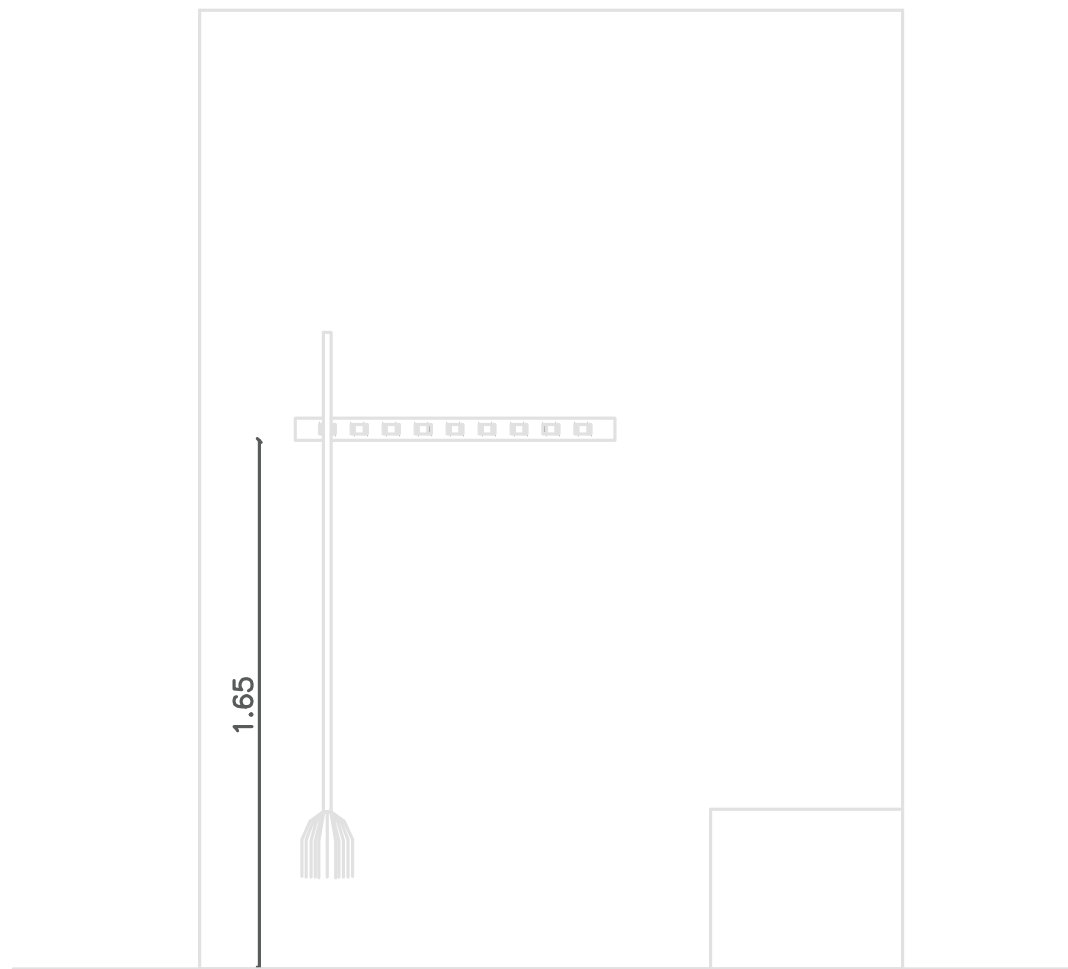

VISTA DE FRENTE

MC 1.191

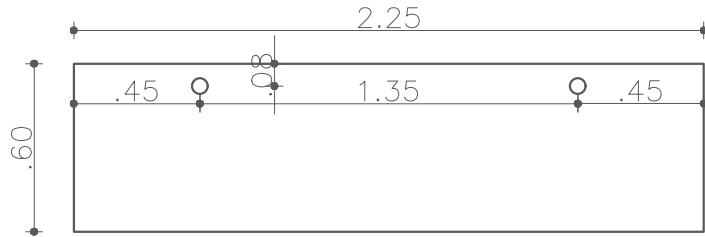

VISTA EN PLANTA SUPERFICIE

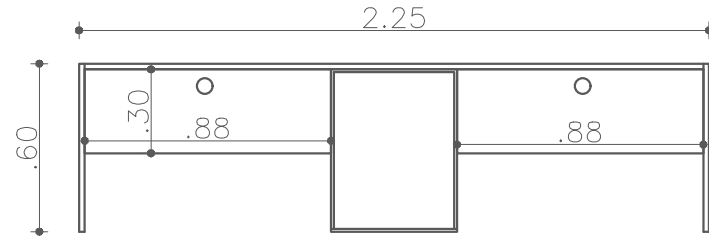

VISTA EN PLANTA BAJO SUPERFICIE

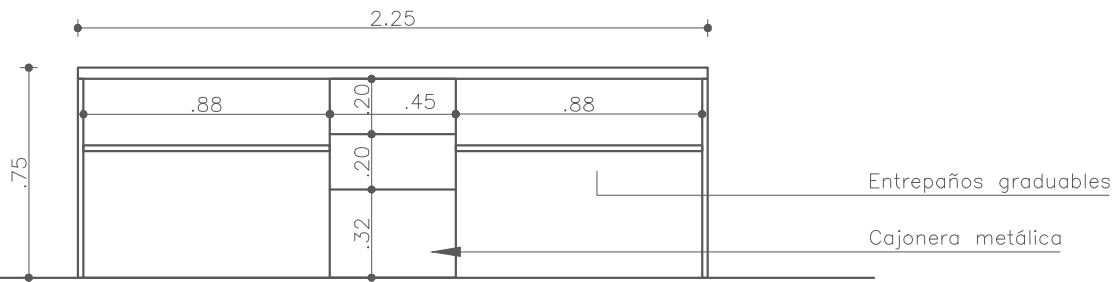

VISTA DE FRENTE

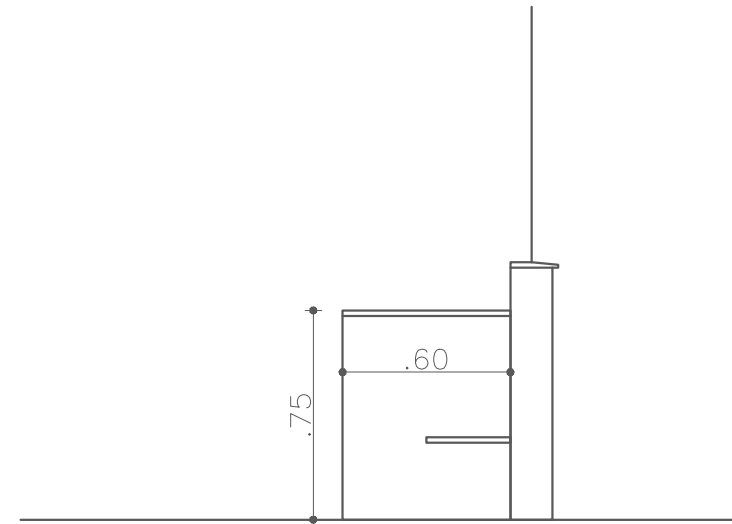

VISTA LATERAL

MC 1.192

